Sheet Metal Dust Pan

Name: _____

Date: _____

Description:

A dust pan will be constructed out of sheet metal by using tools and equipment to make proper bends in the metal and fastened by various means.

Materials:

24 or 26 ga. Galvanized sheet metal
1/8" x 3/8" HR Strip
3/16" x 1/2" pop Rivet

Tools:

Snips
Sheet metal sheer
Sheet metal brake
Spot Welder
Finger Brake
Pop rivet tool
Hacksaw
Drill press
#30 (or 1/8"), 1/4" twist drills
Center punch
Combination square
Scratch awl
Mill file

Procedure:

1. Shear a rectangular piece of sheet metal measuring 16"x12.5"
2. Layout material according to attached plans
3. Drill 1/8" corner holes on a drill press before making any bends (note the back of the dust pan will be spot welded instead of pop riveted and back bend does not need to be drilled)
4. Use snips to cut out laid out material
5. Spot weld in the two spots on each side of the back bend where the holes would have been drilled
6. On the metal cutoff saw measure and cut at piece of 1/8"x2"x2" angle iron at exactly 2" in length
7. On the metal cutoff saw measure and cut a piece of 3/8" black pipe exactly 3.75"
8. On one of the flat sides of the angle iron mark and use a center punch in the exact center (1"x1")
9. Drill in 1/4" hole in the angle iron on the mark in the exact center
10. Mark and drill two 1/8" holes on the edges of the angle iron 1/4" over and 1/4" down (four holes total)
11. On the back brake of the dust pan, mark a 5.5" line indicating the center from the edge
12. Make another mark 1" on either side of the center mark
13. Take the angle iron and place in-between of the marks on either side of the center line and clamp it in place using a vise-grip C-clamp.
14. With it in place drill out the sheet metal where the 1/8" holes are on the angle iron

15. With a 1/4" drill bit drill out the center hole where the handle will go (this should be on the back side and not on the bottom)
16. Use 1/8" x 3/16" aluminum pop rivets to go through the 1/8" holes and crimp using a pop rivet tool
17. Take the 3.75" black pipe and run a 1/4" x 4.5" carriage bolt through the center of the black pipe
18. Thread the remaining end into the 1/4" hole on the angle iron and attach a NC self locking nut on to the bolt and tighten with a

Cutting List:

<u>Quantity</u>	<u>Size</u>	<u>Material</u>
1	16"x12.5"	26ga. Galvanized sheet metal
1	2"x2"x1/8"	Angle iron cut at 2" in length
1	3/8"x3.75"	Black pipe

Notes:

Photo/Drawing:

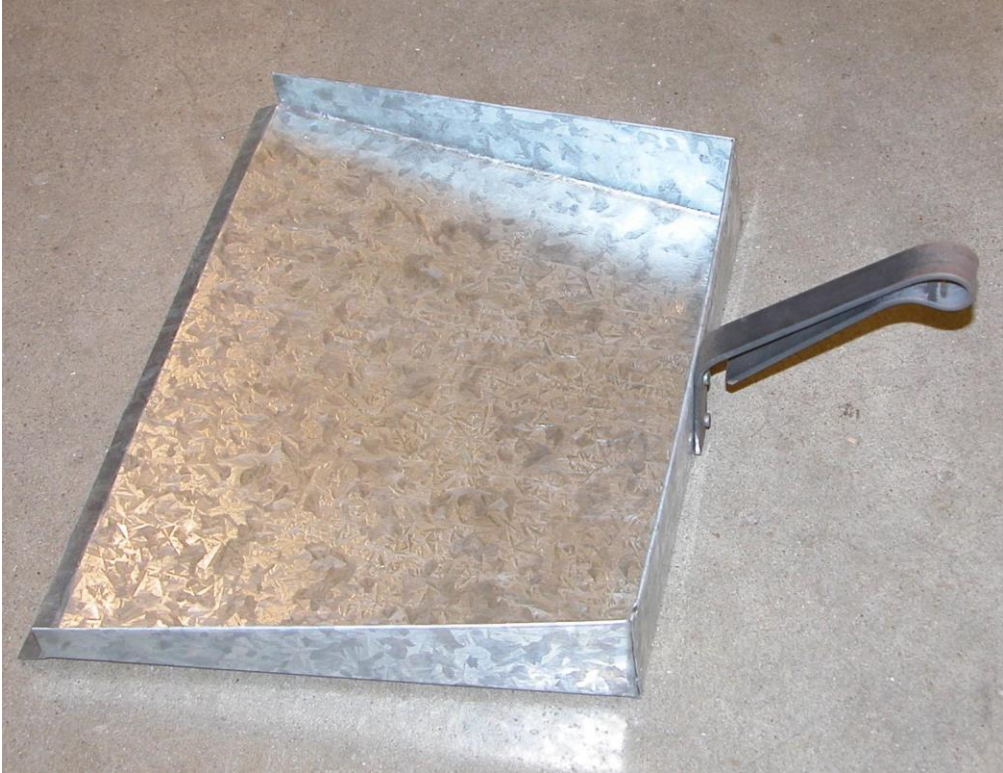

Notes: Layout, cut, and bend sheet metal dustpan. Drill or punch holes for handle after the dustpan back is bent. Spot weld corners. Attach handle with rivets.

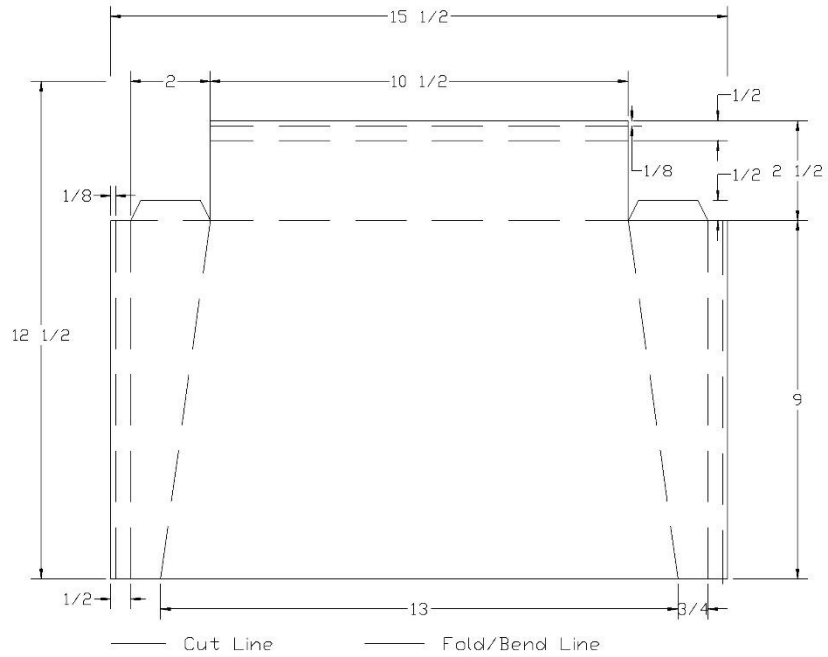

Dustpan		
Drawn By: M. Spiess	Scale: 1:3	Date: 4/15/22

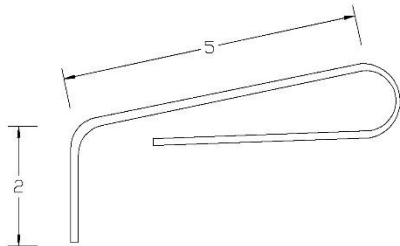

1/8"x3/4" HR drilled to match sheet metal and bent in bender. Size approximate.

Dustpan (handle detail)		
Drawn By: M. Spiess	Scale: 1:2	Date: 4/15/22

Sheet Metal Dust Pan Worksheet

Name: _____

Date: _____

1. What is the name of the tool that will make creases and bends in sheet metal?

2. Will the project go together correctly if the bends are made out of order? Why?

3. What is the purpose of the angle iron for the handle of the project?

4. How many pieces of sheet metal will you need for this project?

5. List some possible ways to change or modify this project?(List 3)

Grading Rubric:

<u>CRITERIA</u>	<u>POSSIBLE</u>	<u>SCORE</u>
Correctness of layout (size)	5	
Bottom of dust pan lays flat on table	5	
Angle iron piece is on straight	5	
Handle is on tight	5	
Overall workmanship	5	
Worksheet	10	
TOTAL	35	

Sheet Metal Dust Pan Teachers Notes:

Agricultural Standards Met:

- 6.0 Health and Safety. Students understand health and safety policies, procedures, regulations, and practices, including the use of equipment and handling of hazardous materials:
- 6.1 Know policies, procedures, and regulations regarding health and safety in the workplace, including employers' and employees' responsibilities.
 - 6.2 Understand critical elements of health and safety practices related to storing, cleaning, and maintaining tools, equipment, and supplies.
 - 6.4 Maintain safe and healthful working conditions.
 - 6.5 Use tools and machines safely and appropriately.
 - 6.6 Know how to both prevent and respond to accidents in the agricultural industry.
- B1.0 Students understand personal and group safety:
- B1.1 Practice the rules for personal and group safety while working in an agricultural mechanics environment.
 - B1.2 Know the relationship between accepted shop management procedures and a safe working environment.
- B2.0 Students understand the principles of basic woodworking.
- B2.3 Know how to identify, select, and implement basic fastening systems.
- B5.0 Students understand agricultural cold metal processes:
- B5.1 Know how to identify common metals, sizes, and shapes.
 - B5.2 Know basic tool-fitting skills.
 - B5.3 Know layout skills.
 - B5.4 Know basic cold metal processes (eg, shearing, cutting, drilling, threading, bending)
 - B5.5 Complete a cold metal project, including interpreting a plan, developing a bill of materials, selecting materials, shaping, fastening, and finishing.

Objectives:

By properly completing this project, students will:

- Properly layout material for cutting
- Properly cut sheet metal using a sheer and snips
- Properly use a sheet metal break to make bends
- Properly use a drill press and twist drill
- Properly use a metal cut off saw
- Properly use a pop rivet tool
- Properly use a spot welder

Alternate Tools and Materials:

- Flat iron instead of angle
- Sheet metal screws, pop rivets, or tinner's rivets to fasten.
- Handle can be made of EMT and brazed (adds a welding component)

Safety Review:

- Safety eyewear
- Break safety
- Spot welder safety
- Sheet metal sheer safety
- Sharp edges

Project Time:

Demonstration:	90 minutes
Build:	3 hours

Demonstration Notes:

1. Tip: Before handing out the plan, show the students the project and ask them to sketch the flat sheet metal.
2. Tip: Handout a copy of the sheet metal plan and have students cut out with scissors then determine the order of the bends.
3. Be sure to bend the material in the correct order to ensure proper fit
4. Be sure to remove the aerosol layout fluid before spot welding
5. Check and have students check the spot welder to ensure the proper setting (too high will burn a hole through it)
6. Have students assist you in constructing the project at any point
7. Be sure that most students can view what you are doing at all times

Bill of Materials: (complete this spreadsheet)

Projects	24					
Size	Description	Units	Qty/Projects	Cost/Unit	Order	Amount
26 ga	Cold Rolled galvanized sheet metal	3' x 8'	0.0833	\$29.50	2	\$ 59.00
1/4"x4.5"	Carraige Bolt	each	1	\$0.05	24	\$ 1.20
1/4" NC	NC self locking nut	each	1	\$0.03	24	\$ 0.72
3/8"	Black water pipe	21'	0.0148	\$ 23.50	1	\$ 23.50
	TOTAL					\$ 84.42

Project from: Ryan Patterson, Ripon High School

Plan by: Daniel Fishman