Electrical Wiring Projects

Name: _____

Date: _____

Description:

Students will learn how to properly install and wire using common industrial devices on an Electrical Board. Students will practice using common electrical testers.

Materials*:

Duplex Receptacle
Lamp Holder with Pig Tail
Switch
3 Way Switches
14 gauge THHN wire of various colors (Red, green, and black)
14/3 Type NM Cable
Wire nuts
Grounding Screws
4" Square Blank Cover
Various plaster rings (mud rings)
*Not all supplies will be used for each scenario.

Tools:

Screwdriver
Needle Nose Pliers
Wire cutter/stripper

Procedure:

1. Review the rules for wiring (text book). Key points are:
 - a. Color coding of wire and terminals. Green=ground, white=neutral, other colors are hot. Brass terminals are hot wires, silver terminals are neutral, green terminals are ground.
 - b. 6" of free conductor.
 - c. Use of wire nuts: tight and no bare wire showing.
 - d. Grounding: boxes and devices.
 - e. Proper connection to a screw terminal: Clockwise, loop $\frac{3}{4}$ around, no insulation under the screw, no bare wire past the device.
2. Complete the worksheet.
3. Wire the assigned project.
 - a. Determine the proper circuit and how you will wire it BEFORE you start wiring.
 - b. Wire the ground wires first.
4. Double check that you have followed the rules and that the wiring is neat.
5. Secure the devices to the boxes with screws for testing.
6. Attach a temporary power cord using wire nuts. OBSERVE color-coding.
7. Using the Testing Circuit Breaker box, plug in your board and test the circuit using a lamp and/or a duplex receptacle tester. Have this portion graded.
8. Disconnect your board. Use a piece of tape to label the board with your name. Remove the screws from the devices and turn in the board for grading.

Notes: _____

The Wiring Board:

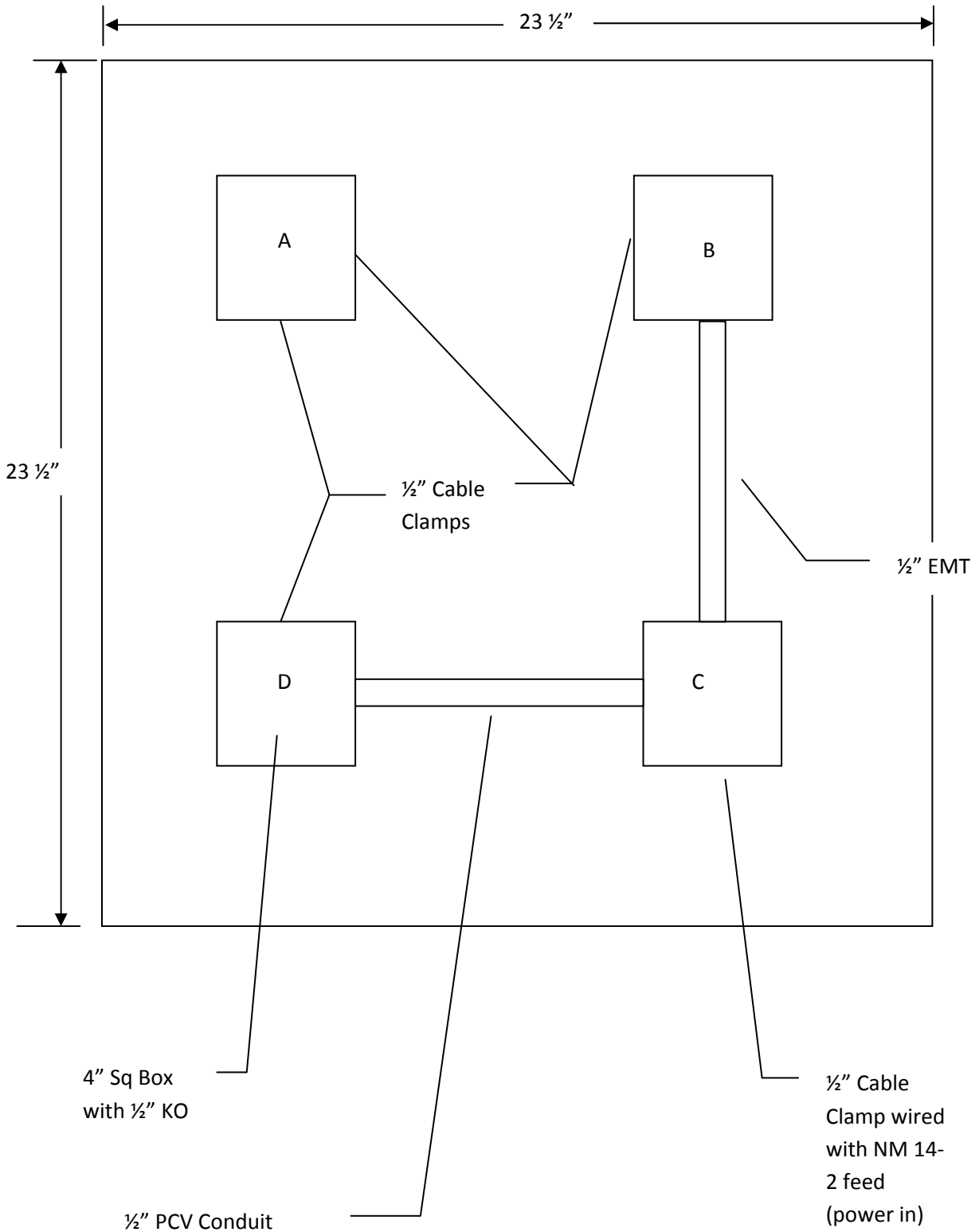

Wiring Projects:

Arrow denotes incoming power (NM Cable).

1.

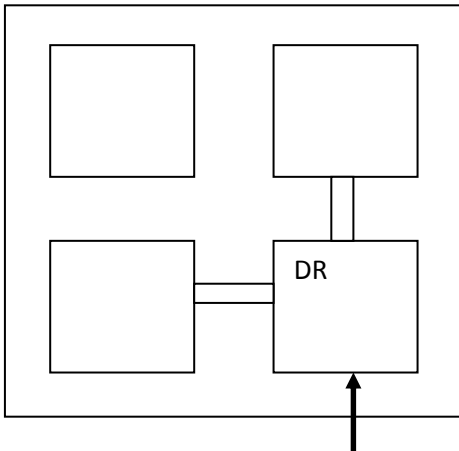

2. Switch controls the lamp

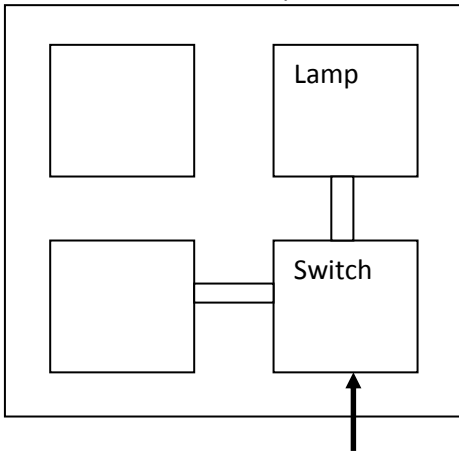

3. Switch controls the lamp

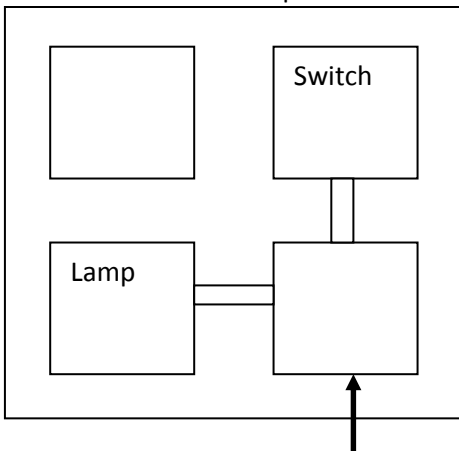

4. Switch controls the lamp. No connection between Boxes D and C.

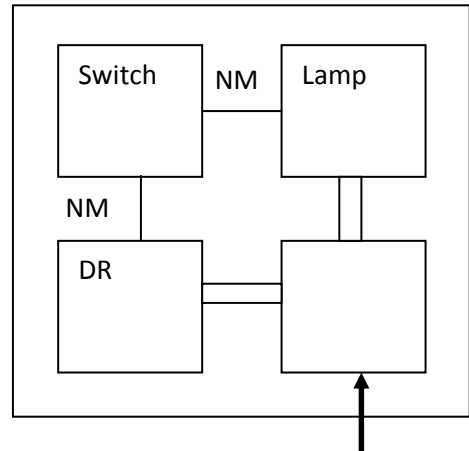

5.

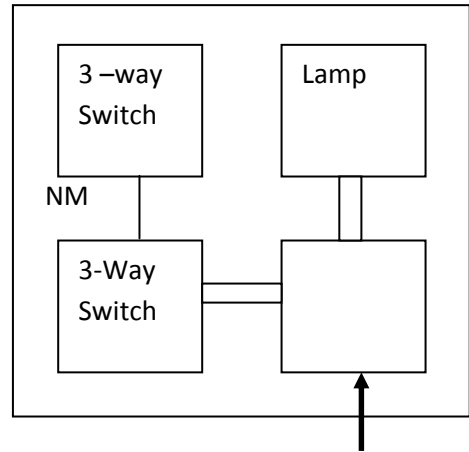

6. Design your own

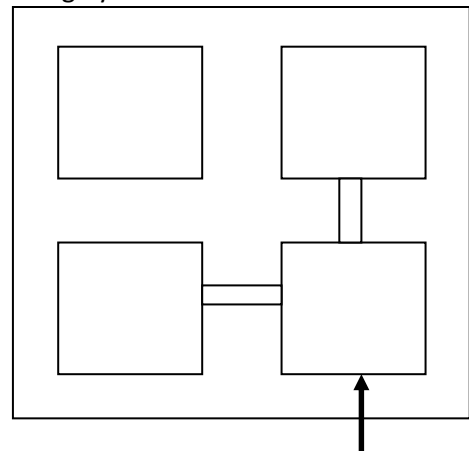

Electrical Wiring Worksheet

Name: _____

Date: _____

1. What do the following wire colors indicate (hot, neutral, ground)?
 - a. White: _____
 - b. Green: _____
 - c. Black: _____
 - d. Red: _____
2. How much free conductor is required for device wiring? _____
3. What do the following terminals (hot, neutral, ground)?
 - a. Brass: _____
 - b. Silver: _____
 - c. Green: _____
4. What type of wire is used in the conduit? _____
5. What direction does the wire wrap on a screw terminal? _____
6. Neatly diagram your circuit. Show wire connections with a line and label or use the wire color.
Complete this for Diagram 1 and Diagram 3. (5 points)

Diagram 1

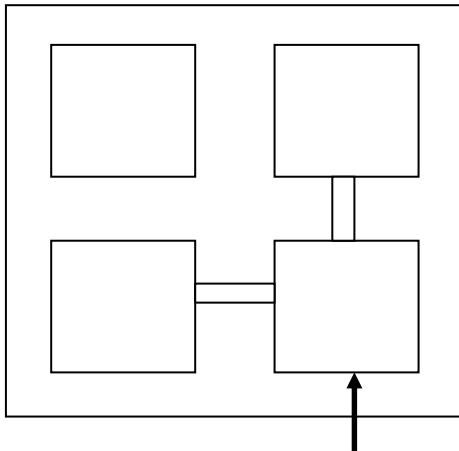
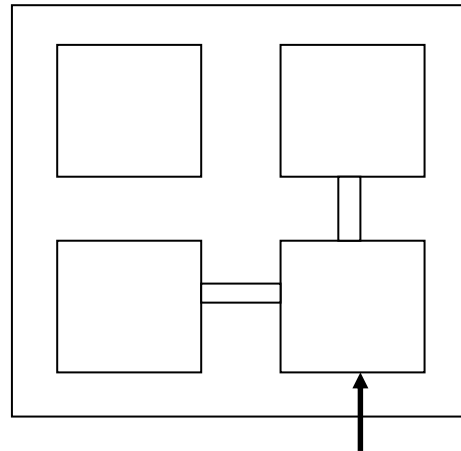

Diagram 3



Grading Rubric:

<u>CRITERIA</u>	<u>POSSIBLE</u>	<u>Problem 1</u>	<u>Problem 2</u>	<u>Problem 3</u>	<u>Problem 4</u>	<u>Problem 5</u>
Proper device location	5					
Properly grounded	5					
Wire color coding	5					
Screw terminals	5					
Wire nuts	5					
Workmanship(no nicks, clockwise loops, neat)	5					
Correct circuit (works)	5					
TOTAL	35					

	Score
Worksheet (10)	
Projects	
Total	

Electrical Wiring Teachers Notes:

For more details of the wiring board look in the CATA Ag Mechanics Curricular Code. With these boards you can make many circuit variations.

Agricultural Standards Met:

6.0 Health and Safety. Students understand health and safety policies, procedures, regulations, and practices, including the use of equipment and handling of hazardous materials:

B1.0 Students understand personal and group safety:

B1.1 Practice the rules for personal and group safety while working in an agricultural mechanics environment.

B1.2 Know the relationship between accepted shop management procedures and a safe working environment.

B3.0 Students understand the basic electricity principles and wiring practices commonly used in agriculture:

B3.3 Analyze and correct basic circuit problems (e.g., open circuits, short circuits, incorrect grounding).

B3.4 Understand proper basic electrical circuit and wiring techniques with nonmetallic cable and conduit as defined by the National Electric Code.

B3.5 Interpret basic agricultural electrical plans.

Objectives:

By properly completing this project, students will be able to:

- Identify the allowable wire color for the types of conductors.
- Explain the correct names of materials.
- Correctly use of wire nuts.
- Can properly wire a circuit.
- Can solve the problem if circuit is not working.
- Demonstrate how to properly wire an electrical device.

Alternative Tools/Methods/Materials:

Similar projects can be developed by using boxes mounted to 2 x 4s. If only NM cable wiring is used then plastic boxes can be used. The project can be modified by changing the scenarios.

Safety Review:

- All power is turned off or disconnected
- Do not use wire with any nicks in it!
- Do not touch electrical with wet hands or feet.
- Check switches, outlets, fixtures or extension cords for damage before using
- Disconnect power source if burning smell or hot.
- Properly wire and double check before testing it!
- Working with electricity can be dangerous. However, electricity can be safe if properly respected.

Project Time:

For 1 project:

Demonstration:	20 minutes
Build:	1 hour

Demonstration Notes

1. Review electrical section of an Ag Mechanics text.
2. Review the types of wire, terms, and names of devices.
3. Cover the basic rules of wiring and discuss the National Electric Code:
 - a. Color coding of wire and terminals
 - b. 6" of free conductor – reason: allows replacement of devices without having to replace the wire.
 - c. Use of wire nuts: tight and no bare wire showing.
 - d. Grounding: boxes and devices.
 - e. Proper connection to a screw terminal: Clockwise, loop $\frac{3}{4}$ around, no insulation under the screw, no bare wire past the device.
4. Cover making "pig tails" to connect devices to multiple wires.
5. Cover basic circuits. Tip: Have students trace a few complete circuits.
6. How to make a proper eye for terminals (bend back 90° first).
Practice this and look like a pro!
7. Build a board with a GFCI, a switch, and a power cord to use for testing. This will protect the student and you if the circuit is bad.
8. Temporary power cords are simply a piece of 14/3 NM cable with a cord cap wired to one end.
9. Use a simple circuit tester. When testing duplex receptacles.
10. At least loosely screw in the devices before connecting to power so they cannot ground to the metal boxes or be touched.
11. Circuits are easily visually checked. It is OK to connect an improper circuit. When it doesn't work ask the student to troubleshoot. Sometimes they learn more this way!

**Bill of Materials:**

Consumables for all projects. Materials in full spools as shown below will build approximately 100 projects. Wire can often be reused.

Projects:		24				
Size	Description	Units	Qty/Project	Cost/Unit	Order	Amount
14/3	Type NM Cable	500 ft	0.02	\$60.00	1	\$ 60.00
14 ga	White THHN wire	500 ft	0.01	\$40.00	1	\$ 40.00
14 ga	Black THHN wire	500 ft	0.01	\$40.00	1	\$ 40.00
14 ga	Green THHN wire	500 ft	0.01	\$ 40.00	1	\$ 40.00
14 ga	Red THHN wire	500 ft	0.01	\$ 40.00	1	\$ 40.00
					TOTAL	\$ 220.00

Materials (per board):

These are basically non-consumable. Prices are 2010 (Home Depot).

Quantity	Description	Price	Amount
0.125	½ CC Plywood board (8 per sheet)	\$ 26.00	\$ 3.25
4	4" sq. Electrical boxes with ½" KO	\$ 0.97	\$ 3.88
2	½" EMT Box connectors	\$ 1.91	\$ 3.82
2	½" PVC Box connectors	\$ 1.33	\$ 2.66
scrap	8" of ½" EMT	NA	
scrap	8" of ½" PVC Conduit	NA	
4	Grounding screws installed in the box	\$ 0.08	\$ 0.32
3	Single gang ½" plaster ring	\$ 0.97	\$ 2.91
1	3" round ½" plaster ring	\$ 1.14	\$ 1.14
3	4" square blank cover.	\$ 0.57	\$ 1.71
5	½" NM cable clamps	\$ 0.40	\$ 2.00
1	Duplex Receptacle	\$ 0.59	\$ 0.59
2	Lamp holder with pig tails and mountable in the round plaster ring.	\$ 1.19	\$ 2.38
1	switch	\$ 0.69	\$ 0.69
2	3 way switches	\$ 1.48	\$ 2.96
500	Yellow wire nuts	\$ 4.59	\$ 4.59

Project from: Jamie Marron