

SAW HORSE

BILL OF MATERIALS

Materials Needed	Quantity	Dimensions	Description or Use
LUMBER	1 piece	1" × 6" × 10'-0"	Side boards
	2 pieces	$\frac{7}{8}$ " × 5½" × 36"	
	2 pieces	$\frac{7}{8}$ " × 5½" × 14"	Leg braces
	1 piece	2" × 6" × 12"	End blocks
	2 pieces	1¾" × 5½" × 6"	
	1 piece	1" × 4" × 8'-0"	Legs
	4 pieces	$\frac{7}{8}$ " × 3¾" × 24"	
HARDWARE			
Wood screws	44	1½"	No. 12 flat head

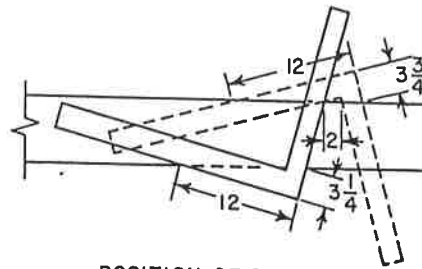
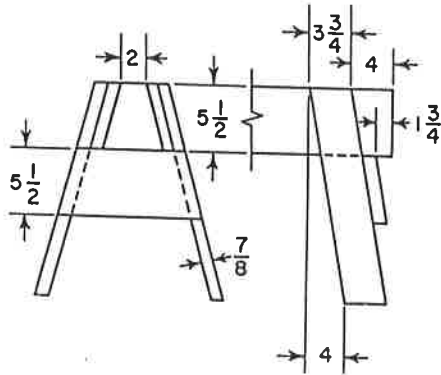

POSITION OF SQUARES TO CUT END BLOCK

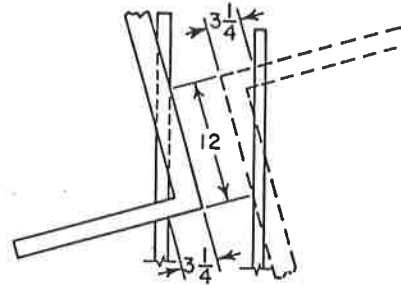

POSITION OF SQUARES TO CUT BEVEL

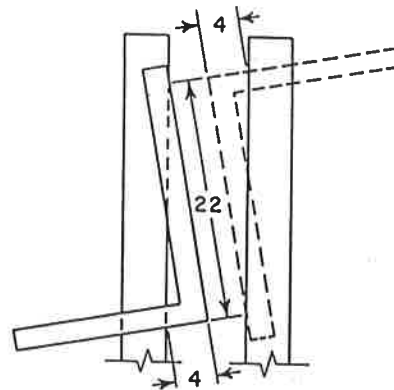
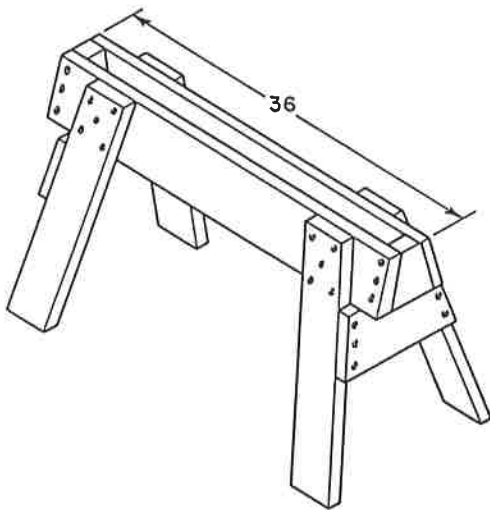

POSITION OF SQUARES TO CUT BEVEL

HEAVY-DUTY SAW HORSE

BILL OF MATERIALS

Materials Needed	Quantity	Dimensions	Description or Use
LUMBER, HARDWOOD			
	2 pieces	2" x 4" x 8'-0"	Top
	2 pieces	1 3/4" x 3 3/4" x 36"	Legs
	4 pieces	1 3/4" x 3 3/4" x 20"	Legs
	1 piece	1" x 6" x 8'-0"	Side boards
	2 pieces	7/8" x 5 1/2" x 32"	Leg braces
	2 pieces	7/8" x 5 1/2" x 10 1/2"	Leg braces
HARDWARE			
Wood screws	8	3"	No. 12 flat head
	28	2"	No. 12 flat head
Carriage bolts	4	1/4" x 3"	
Washers	4	1/4"	Flat

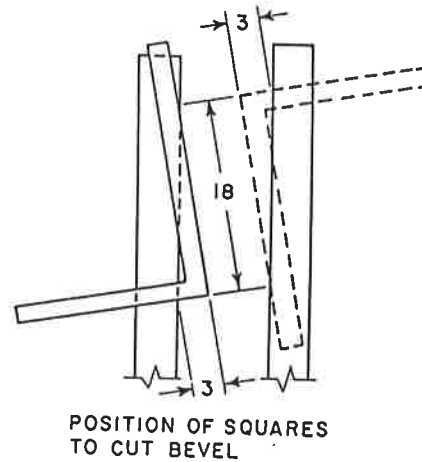
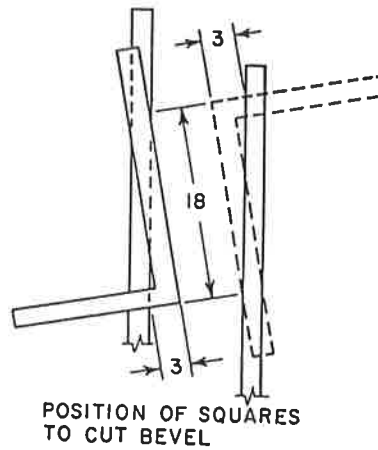
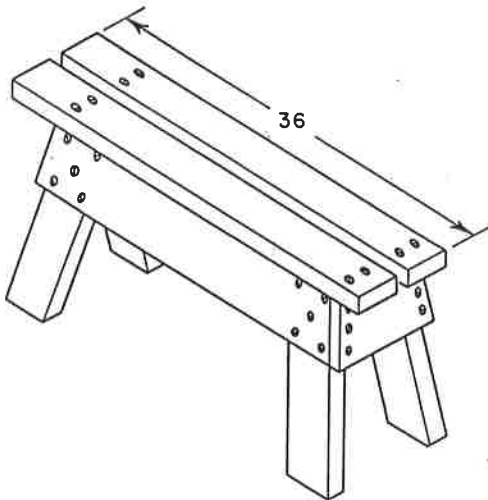
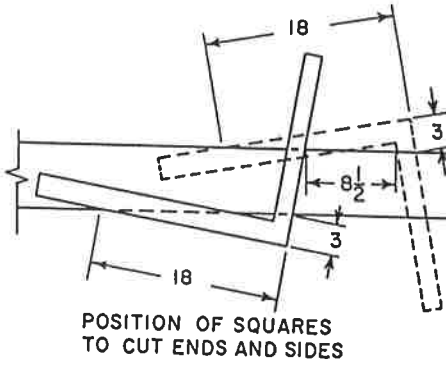
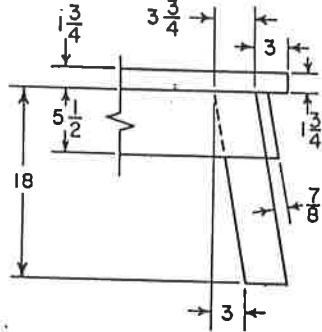
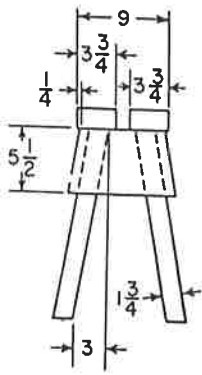

HEAVY DUTY SAW HORSE

