2 Step Stool - Chico

Name: _____

Description:

This project provides students the opportunity to work on wood working skills. Use of dimensional lumber is good practice for construction projects. Cutting angles and notches are skills typically used in roof framing.

Materials:

2" x 4" #2 or btr fir
1"x 6" #3 common pine
5d finish nails
6 x 2" course drywall screws
Wood glue
Sand Paper

Tools:

Miter Saw
Circular Saw
Combination square
Sliding T Bevel
½" wood chisel
Steel Tape
Claw Hammer
Nail Set
Hand Plane
Power drill with screw driver bit

Directions:

1. Review the plan. Select your lumber and determine the best layout.
2. *Cut the legs from 2x4 stock on the power miter saw set to the desired angle.
3. Layout the notches in the legs using a square and the T bevel.
4. Set the circular saw to the depth of the notch. Clamp the leg to the table or saw horse and carefully cut the edges of the notch. Make several passes with the saw on the interior of the notch. Remove the excess wood with the chisel to make a clean notch.
5. Assemble the legs using glue and drywall screws. NOTE: The leg assemblies are mirror images of each other, DO NOT MAKE THE SAME
6. *Cut the top step to length (1x6) and chamfer the front and back with the hand plane (use a smoothing or jack).
7. *Cut the step and brace on the power miter saw (square cuts). Chamfer the step to match leg angle.
8. Install the step and brace on the leg assemblies using glue and wood screws.
9. Locate the top step and install with glue and finish nails. Counter sink the nails.
10. All screws should be countersunk.
11. Sand with a sanding block.
12. Write your name on the bottom of the top step.

Drawing:

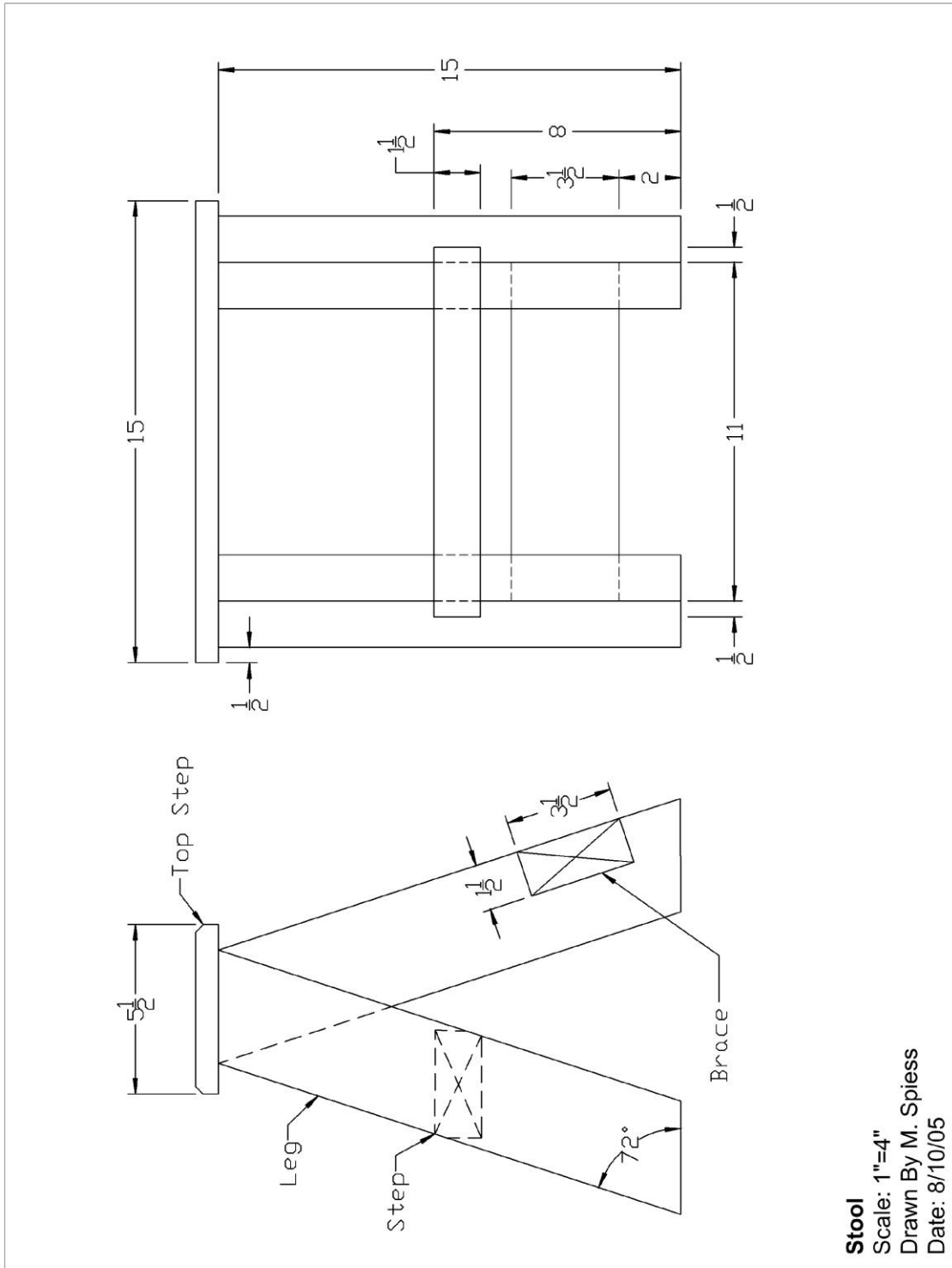



Step Stool Student Worksheet:

Name: _____

Complete this worksheet prior to starting the project.

1. What angle is used to set the miter saw when cutting the legs? _____
2. What type of fasteners are used to secure the top of the stool? _____
3. What type of fasteners are used to secure the step of the stool? _____
4. How will you cut the notches?

5. What precautions should be used when using a wood chisel?

Grading Rubric:

Criteria (tolerance +/- 1/16")	Possible	Score
Dimensions	5	
Notch quality	5	
Correct use of fasteners	5	
Stool square and does not rock	5	
General Workmanship (sanding, edges, excess marks, scaring of wood)	5	
TOTAL	25	

Step Stool Teaching Notes:

Agricultural Standards Met:

- 4.0 Technology. Students know how to use contemporary and emerging technological resources in diverse and changing personal, community, and workplace environments:
 - 4.6 Differentiate among, select, and apply appropriate tools and technology.
- 5.0 Problem Solving and Critical Thinking. Students understand how to create alternative solutions by using critical and creative thinking skills, such as logical reasoning, analytical thinking, and problem-solving techniques:
 - 5.1 Apply appropriate problem-solving strategies and critical thinking skills to work-related issues and tasks.
 - 5.3 Use critical thinking skills to make informed decisions and solve problems.
- 6.0 Health and Safety. Students understand health and safety policies, procedures, regulations, and practices, including the use of equipment and handling of hazardous materials:
 - 6.1 Know policies, procedures, and regulations regarding health and safety in the workplace, including employers' and employees' responsibilities.
 - 6.2 Understand critical elements of health and safety practices related to storing, cleaning, and maintaining tools, equipment, and supplies.
 - 6.4 Maintain safe and healthful working conditions.
 - 6.5 Use tools and machines safely and appropriately.
 - 6.6 Know how to both prevent and respond to accidents in the agricultural industry.
- B1.0 Students understand personal and group safety:
 - B1.1 Practice the rules for personal and group safety while working in an agricultural mechanics environment.
 - B1.2 Know the relationship between accepted shop management procedures and a safe working environment.
- B2.0 Students understand the principles of basic woodworking:
 - B2.1 Know how to identify common wood products, lumber types, and sizes
 - B2.3 Know how to identify, select, and implement basic fastening systems.
 - B2.4 Complete a woodworking project, including interpreting a plan, developing a bill of materials, and cutting list, selecting materials, shaping, joining and finishing.

Objectives:

By successfully completing this project students will be able to:

- Read a plan to obtain critical dimensions
- Measure and layout a project on wood using common layout tools
- Identify by name common wood working tools
- Select and properly used hand and power tools used for wood working

Alternate Tools/Materials:

A dado blade can be used to cut the notches. Caution should be used for this setup. A band saw can be used to cut the brace notch.

Safety Review:

- Use of all power tools
- Caution when using a wood chisel (very sharp).

Project Time:

Demonstration: 15-30 minutes

Build: 3 hours

Demonstration Notes:

1. Begin by reviewing materials and tools used for the project.
2. Review the plan and show how the plan describes the project.
3. Explain why lumber selection is critical (avoid knots).
4. Explain how to determine saw angle ($90-72=18$)
5. Demonstrate proper use of miter saw and review safety precautions.
6. Demonstrate the step notch layout with the T bevel.
7. Tie lay out skills to building construction (roof framing).
8. Remind students of workmanship. Final projects should be sanded and free of any excess glue.

Bill of Materials

Projects:

18

Size	Desc	Units	Qty/Project	Cost/Unit	Order	Amount
1" x 6" x 8'	#3 common pine	each	0.1666	\$ 6.00	3	\$ 18.00
2" x 4" x 8'	#2 or btr Fir	each	1	\$ 4.50	18	\$ 81.00
6 x 2"	Course drywall screws	1 lb box	0.1	\$ 5.00	2	\$ 10.00
5d	Finishing nails	1 lb box	0.1	\$ 4.00	2	\$ 8.00
	Wood glue	1 pt	0.05	\$ 4.00	1	\$ 4.00
					TOTAL	\$ 121.00