



California Vocational Agriculture Curriculum Guidelines Instructional Unit

MEASUREMENTS

TABLE OF CONTENTS

	<u>Page</u>		
		Introduction to Agriculture	
PART I. Unit Goal and Performance Objectives	1	Agricultural Production	01.01
PART II. Main Text.	2-3	Agricultural Supplies/Services	01.02
Teaching Outline.	2		
Suggested Learning Activities.	3	Agricultural Mechanics	01.03
Suggested Resource Materials	3	Agricultural Products/Processing	01.04
PART III. Unit Evaluation.	4	Ornamental Horticulture	01.05
PART IV. Teaching Aids.	5-11		
PART V. General References	12	Renewable Resources/ Rural Recreation	01.06
		Forestry	01.07

MEASUREMENTS

Unit Goal:

To give the student the ability to properly utilize measuring tools used in agricultural shops and other mechanics areas.

Unit Performance Objectives:

Upon completion of this unit the student will be able to:

1. Correctly read a ruler, tape, or framing square.
2. Correctly read a surveyor's rod.
3. Understand and be able to use calipers and micrometers.
4. Calculate and solve basic measurement problems.
5. Differentiate between English and Metric measurements units.

Suggested Learning Activities

General

1. TM - 1, 2. Each student has a ruler and is asked to locate certain points on the ruler.
2. Have rods in class and show differences. Have students locate certain points.
3. Have students check measurements using calipers.
4. Have student check micrometer for accuracy at 0.0 inches-- measure thickness of different objects, this paper, different leaves of a feeler gauge or a combination of the leaves on a feeler gauge.
5. Have students measure a small shop project to determine materials needed to construct one. Figure cost, work alternate problems converting cu. ft. to gal. or cu. yds. or sq. ft. to lbs. etc.

Suggested Resource Materials

1. TM - 1 and TM - 2; rulers.
2. TM - 3 and TM - 4; rods.
3. TM - 5 and calipers.
4. TM - 6 and micrometers.

Student Evaluation

Unit: Measurements

Name _____

Date _____

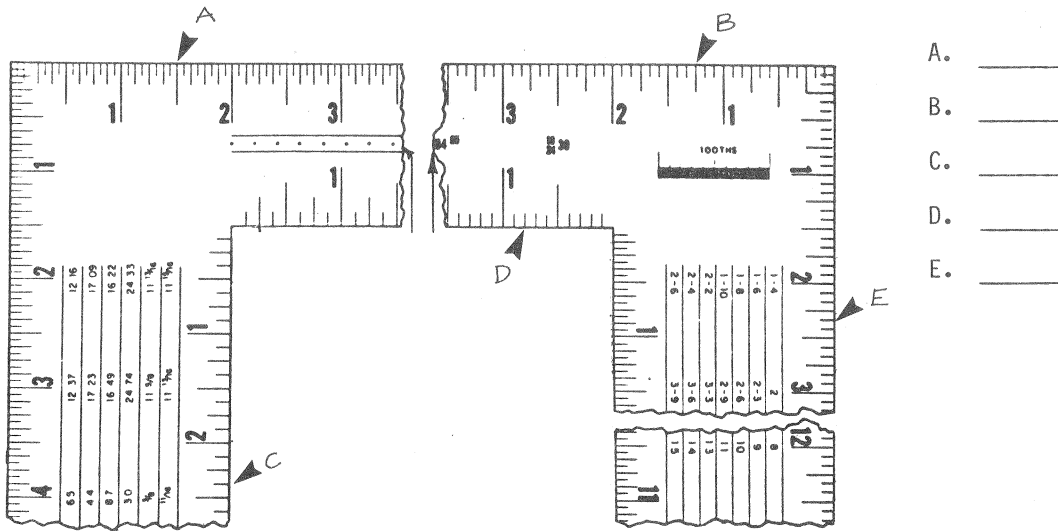

Examples of rod readings.

Draw the micrometer settings for the following:

A. .250

B. .500

C. .065

D. .637

UNITS OF MEASUREMENT

TM-1

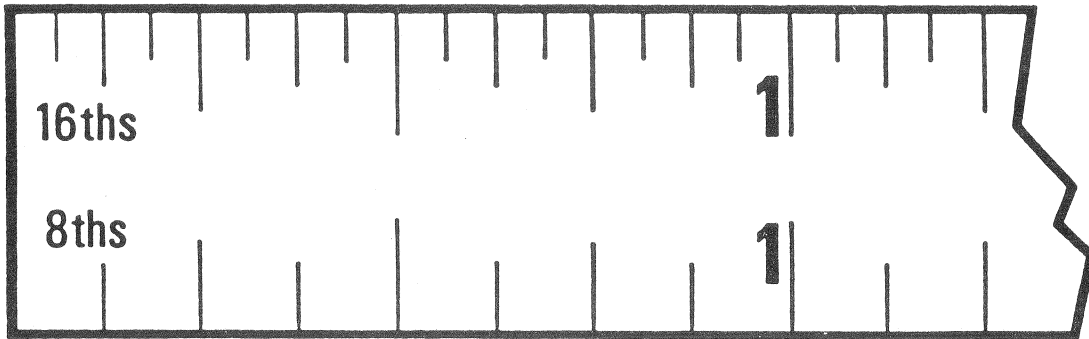

Fractional Rule

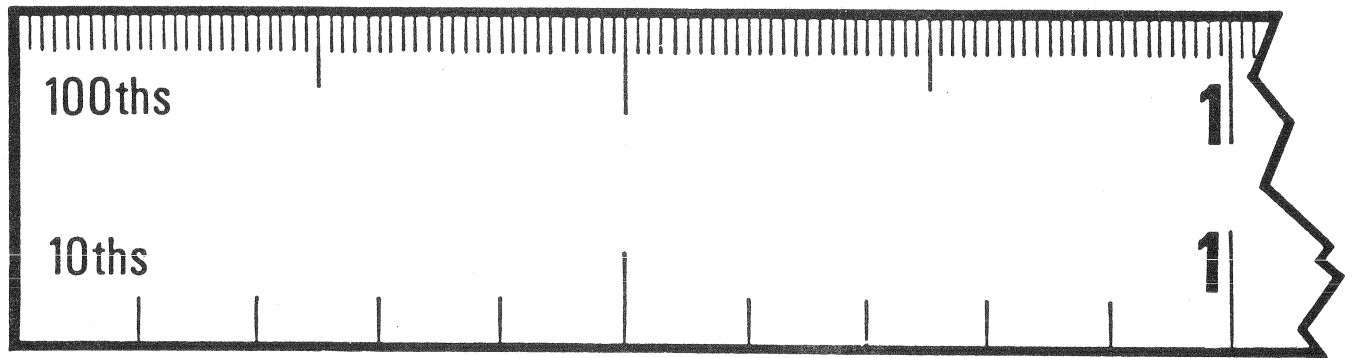

Decimal Rule

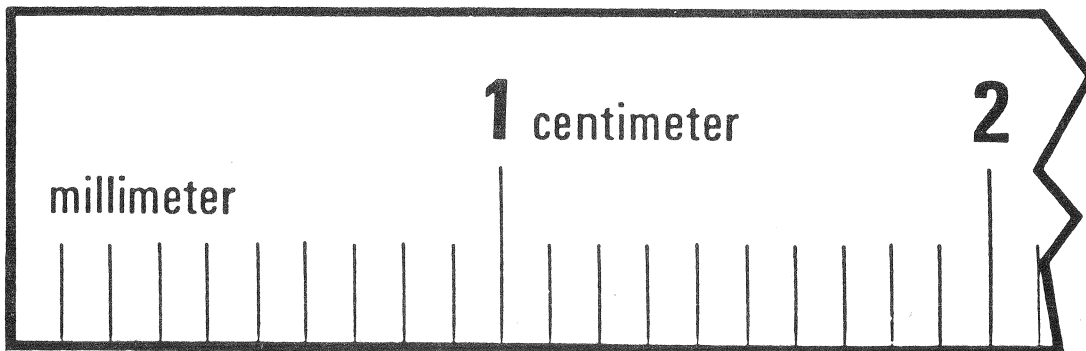

Metric Rule

FRAMING SQUARE

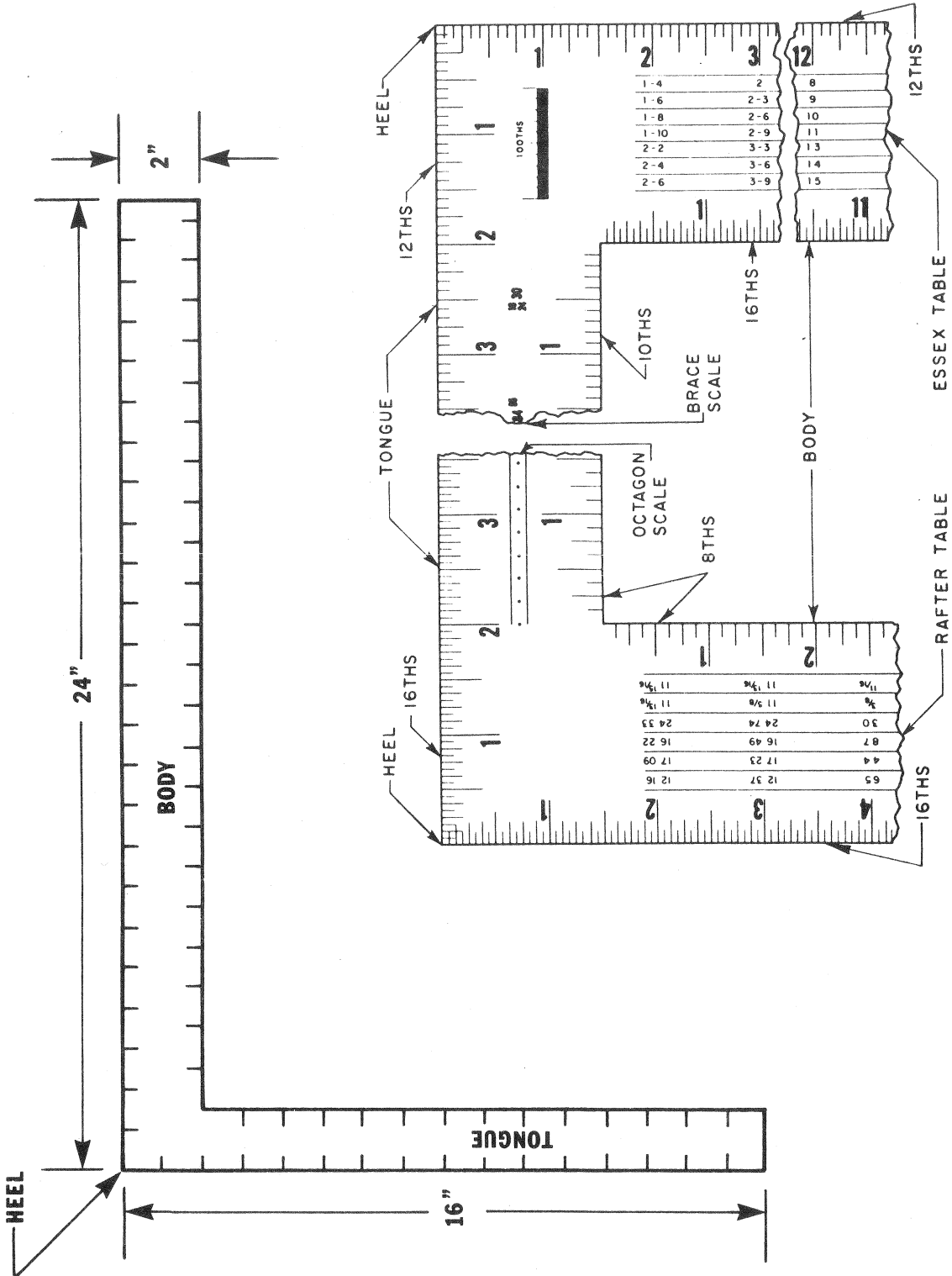

SURVEYING RODS

TM-3

A.

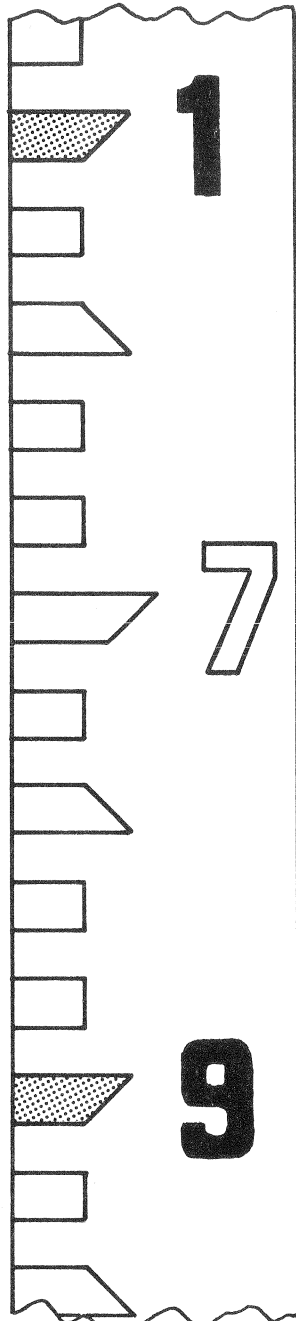

Feet, $\frac{1}{10}$'s, $\frac{1}{100}$'s

B.

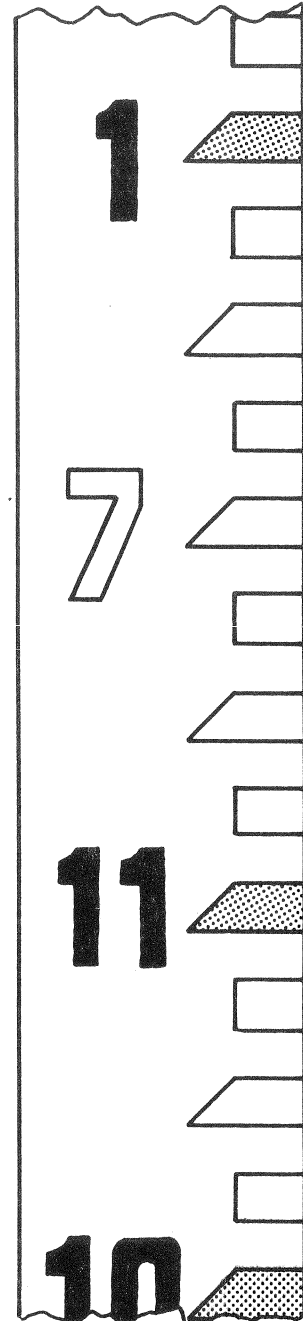

Feet, inches, $\frac{1}{8}$ inches

VERNIER CALIPER

TM-4A

- A. SLEEVE
- B. LOCK
- C. SPINDLE
- D. ANVIL
- E. RATCHET STOP
- F. THIMBLE
- G. FRAME

1. NUMBERED GRADUATION ON THE SLEEVE = 0.100"
2. GRADUATIONS BETWEEN NUMBERS ON THE SLEEVE = 0.025
3. GRADUATIONS ON THIMBLE = 0.001

MICROMETER

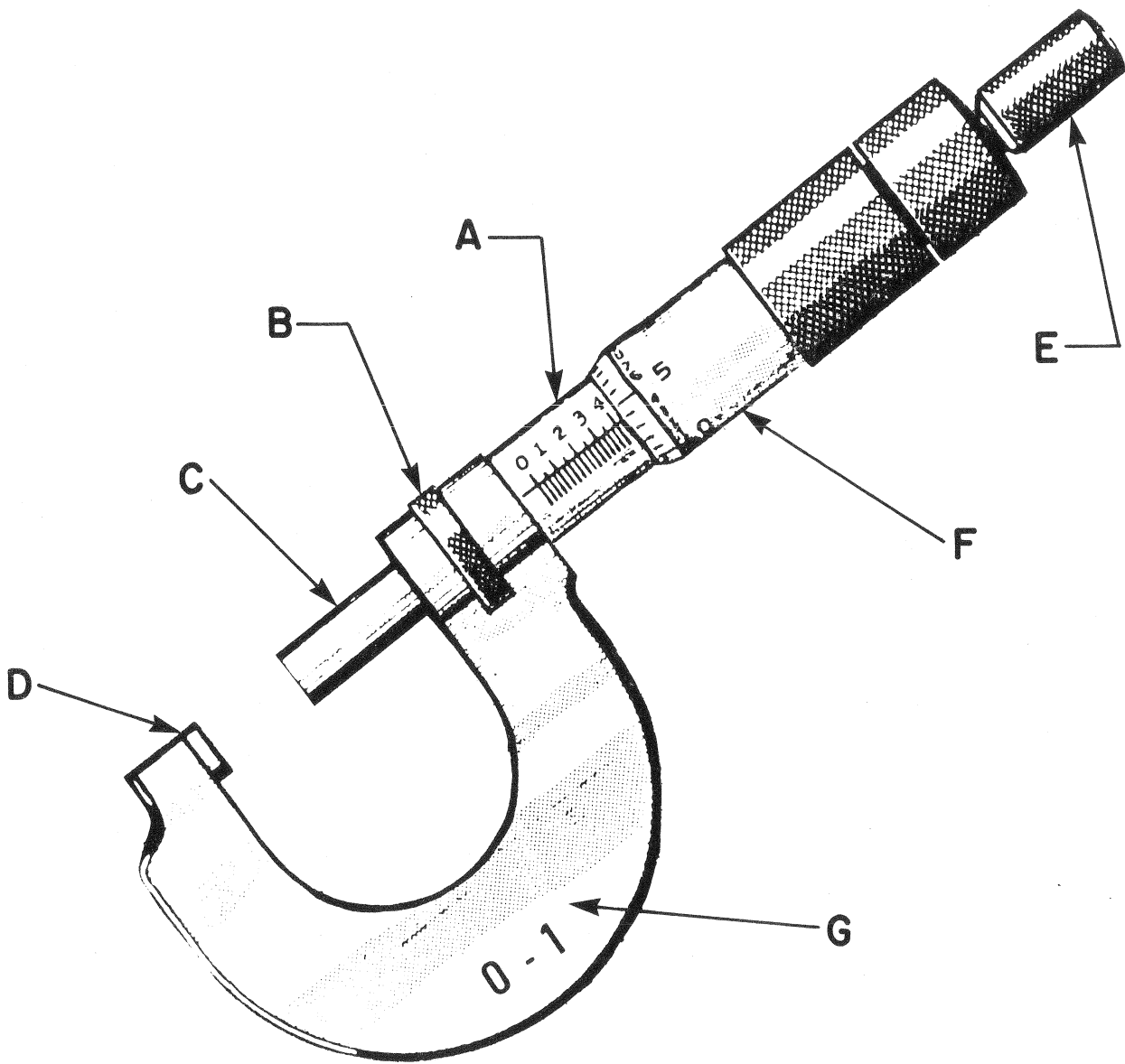

MICROMETER

TM-5A

- A. BEAM
- B. CLAMP
- C. CLAMP SCREWS
- D. MAIN SCALE
- E. ADJUSTING NUT
- F. VERNIER SCALE
- G. MOVABLE JAW
- H. FIXED JAW

General References