

Mobile Irrigation Lab (MIL) Technical Handbook



United States Department of Agriculture,
Natural Resources Conservation Service
and
Florida Department of Agriculture and
Consumer Services
May 2017

The U.S. Department of Agriculture (USDA) prohibits discrimination against its customers. If you believe you experienced discrimination when obtaining services from USDA, participating in a USDA program, or participating in a program that receives financial assistance from USDA, you may file a complaint with USDA. Information about how to file a discrimination complaint is available from the Office of the Assistant Secretary for Civil Rights. USDA prohibits discrimination in all its programs and activities on the basis of race, color, national origin, age, disability, and where applicable, sex (including gender identity and expression), marital status, familial status, parental status, religion, sexual orientation, political beliefs, genetic information, reprisal, or because all or part of an individual's income is derived from any public assistance program. (Not all prohibited bases apply to all programs.)

To file a complaint of discrimination, complete, sign, and mail a program discrimination complaint form, available at any USDA office location or online at www.ascr.usda.gov, or write to:

USDA
Office of the Assistant Secretary for Civil Rights
1400 Independence Avenue, SW.
Washington, DC 20250-9410

Or call toll free at (866) 632-9992 (voice) to obtain additional information, the appropriate office or to request documents. Individuals who are deaf, hard of hearing, or have speech disabilities may contact USDA through the Federal Relay service at (800) 877-8339 or (800) 845-6136 (in Spanish). USDA is an equal opportunity provider, employer, and lender.

Persons with disabilities who require alternative means for communication of program information (e.g., Braille, large print, audiotape, etc.) should contact USDA's TARGET Center at (202) 720-2600 (voice and TDD).

TABLE OF CONTENTS

CHAPTER 1. Introduction	1-1
1.1 Irrigation in Florida	1-1
1.2 Mobile Irrigation Lab Technical Handbook.....	1-2
<hr/>	
CHAPTER 2. Irrigation System Evaluations	2-1
2.1 Introduction	2-1
2.2 Performance Terms	2-1
2.3 Farm Irrigation Rating Index.....	2-2
2.4 Evaluation of Microirrigation Systems	2-4
2.4.1 Equipment Required	2-4
2.4.2 Field Procedure	2-5
2.4.3 Calculations.....	2-5
2.4.4 Analysis of Evaluation Results	2-6
2.4.5 Typical Problems and Recommendations for Microirrigation Systems	2-7
2.5 Evaluation of Sprinkler Irrigation Systems	2-9
2.5.1 Evaluation of Fixed and Portable Lateral Sprinkler Systems (Solid Set and Linear Move).....	2-9
2.5.1.1 Equipment Required	2-10
2.5.1.2 Field Procedure	2-10
2.5.1.3 Calculations.....	2-12
2.5.2 Evaluation of Traveling Gun Sprinkler System.....	2-14
2.5.2.1 Equipment Required	2-14
2.5.2.2 Field Procedure	2-14
2.5.3 Evaluation of Center Pivot Sprinkler System	2-15
2.5.3.1 Equipment Required	2-15
2.5.3.2 Field Procedure	2-15
2.5.4 Analysis of Sprinkler System Evaluations (Solid Set, Linear Move, Traveling Gun, and Center Pivot)	2-16
2.5.5 Typical Problems and Recommendations for Sprinkler Irrigation Systems.....	2-18
2.6 Evaluation of Subirrigation Systems (Flow Through and Underground Conduit)	2-20
2.6.1 Equipment Required	2-21
2.6.2 Field Procedure	2-22
2.6.3 Analysis of Subirrigation System	2-23
2.6.4 Typical Problems and Recommendations for Subirrigation Systems.....	2-24
<hr/>	
CHAPTER 3. Evaluation of Urban Irrigation Systems	3-1
3.1 Common System Components in Urban Irrigation.....	3-1
3.1.1 Matched Rates.....	3-6
3.1.2 Sprinkler Spacing.....	3-6
3.1.3 Mixed Zones	3-7
3.1.4 Soil Texture Determination.....	3-7
3.1.5 Determine Distribution Uniformity.....	3-9

3.1.6 Materials List	3-9
3.1.7 Visual Inspection.....	3-9
3.1.8 Pressure and Flow Test	3-9
3.1.9 Catch Can Test.....	3-9
3.1.10 Other Miscellaneous Equipment	3-10
3.2 Visual Inspection.....	3-10
3.3 Pressure and Flow Inspection.....	3-15
3.4 Catch Can Distribution Uniformity Test.....	3-17
3.4.1 Selecting Catch Can Containers.....	3-18
3.4.2 Selecting a Zone or Zones.....	3-18
3.4.3 Placing Catch Cans	3-18
3.4.4 Selecting Subzones	3-21
3.4.5 Test Duration.....	3-22
3.4.6 Mesuring and Recording Data	3-22
3.4.7 Application Rate	3-23
3.5 Plant Watering Requirements and Operating Times.....	3-26
3.6 Water Usage for Urban Irrigation Systems	3-27
3.7 Presentation of Urban Evaluation	3-31
3.7.1 Visual Inspection.....	3-31
3.7.2 Pressure and Flow	3-31
3.7.3 Catch Can Test.....	3-31
3.8 Steps to Conducting an Evaluation	3-32
3.8.1 Average Application Rate	3-32
3.8.2 Meter Records Water Use in Gallons	3-33
3.8.3 Meter Records Water Use in Cubic Feet	3-33
3.8.4 No Meter Present	3-33
3.8.5 Determine Distribution Uniformity	3-34
3.8.6 Determine the Effective Application Rate.....	3-35
3.8.7 Calculate Operating Time	3-35
3.8.8 Determine Water Used per Operating Cycle	3-35
3.8.9 Make System Recommendations	3-36
3.9 Typical Problems and Recommendations for Urban Irrigation Systems.....	3-36
3.10 Reporting Results of Urban Irrigation Evaluations.....	3-37

CHAPTER 4. Water Conservation Report 4-1

4.1 Introduction.....	4-1
4.2 Determining the Maximum and Actual Distribution and/or Emission Uniformities of a Pressurized Pipe Irrigation System	4-1
4.3 Calculating Potential Water Savings (PWS).....	4-5
4.4 Calculating Actual Water Savings (PWS)	4-8
4.5 Calculating Immediate Water Savings (PWS).....	4-11
4.6 Reporting Water Conservation Results to Partner Agencies	4-11
4.7 Typical Water Conservation Report to the Farmer or Client.....	4-12
4.7.1 Agricultural.....	4-13
4.7.1.1 Center Pivot Irrigation System Evaluation	4-13
4.7.1.2 Microirrigation System Evaluation.....	4-18

4.7.2 Urban.....	4-34
4.7.2.1 Urban Irrigation System Evaluation	4-34
4.8 Irrigation Water Management Plans	4-42
4.8.1 Sample Irrigation Water Management Plan for Center Pivot Sprinkler Irrigation System.....	4-43
4.8.2 Sample Irrigation Water Management Plan for Traveling Gun Sprinkler Irrigation System.....	4-47
4.8.3 Sample Irrigation Water Management Plan for Microirrigation System.....	4-50
4.8.4 Sample Irrigation Water Management Plan for Subsurface – Flow Through Irrigation System.....	4-51
4.8.5 Florida NRCS Form FL-ENG-449A	4-53
4.8.6 Florida NRCS Form FL-ENG-449B.....	4-54
<hr/>	
CHAPTER 5. Resources.....	5-1
5.1 Training	5-1
5.2 MIL Evaluation Field Forms.....	5-2
<hr/>	
CHAPTER 6. Irrigation Safety	6-1
<hr/>	
FIGURES	
Figure 1 – State Water Management District Service Area.....	1-4
Figure 2 – Agricultural MIL Service Area Map	1-5
Figure 3 - Urban MIL Service Area Map.....	1-6
Figure 4a – Example Solid Set Catch Can Layout.....	2-11
Figure 4b – Example Solid Set Catch Can Layout.....	2-11
Figure 5 – Hybrid Controller.....	3-3
Figure 6 – Pressure Vacuum Breaker.....	3-3
Figure 7 – Remote Control Valve	3-4
Figure 8 – Pop – Up Spray Sprinkler	3-4
Figure 9 – Impact Spray Sprinkler	3-5
Figure 10 – Xeri – Tube - PC.....	3-5
Figure 11 – Automatic Rain Shutoff.....	3-6
<hr/>	
TABLES	
Table 1 – MIL Offices and Counties Served.....	1-3
Table 2 – Test Results, Problems, and Solutions for Microirrigation Systems	2-7
Table 3 – Test Results, Problems and Solutions for Sprinkler Systems	2-18
Table 4 – Maximum Potential System Uniformity	4-2
<hr/>	
APPENDICES	
Appendix A – Irrigation System Problems and Codes	
Appendix B – Procedures for Accessing NRCS Web Soil Survey	
Appendix C – Evaluation Spreadsheets	
Appendix D – Glossary, Conversion Chart and References	

THIS PAGE INTENTIONALLY LEFT BLANK

Chapter 1— Introduction

The United States Department of Agriculture (USDA), Natural Resources Conservation Service (NRCS), in cooperation with the Florida Department of Agriculture and Consumer Services (FDACS) and the five (5) Water Management Districts (WMD) (see Figure 1), have increased technical assistance to irrigators in the wise use of water through the use of Mobile Irrigation Labs (MILs).

Eighteen (18) MILs are currently operating in Florida and serve sixty-seven (67) counties as listed in Table 1. Figure 2 and Figure 3 displays the counties served by each MIL in Florida. MILs provide irrigation technical assistance on agricultural and urban lands for landowners on a voluntary basis. The MIL operators perform irrigation evaluations and based on the evaluations, irrigation systems management recommendations are provided to the irrigator. MILs have been successful in assisting irrigators in the proper operation and management of their irrigation systems resulting in water conservation. The MILs promote irrigation systems designed to meet the technical requirements of the NRCS Field Office Technical Guides (FOTG), <https://efotg.sc.egov.usda.gov/>.

In addition to conducting evaluations, the MILs conduct workshops, are guest speakers at various events, perform public relations activities with partner agencies, work with teachers in the school systems and engage in other activities relating to water conservation.

1.1 Irrigation in Florida

Like many other elements of agribusiness, irrigation acreage has increased at a phenomenal rate subsequent to 1950. Florida currently ranks eleventh nationally of all states in the amount of irrigated acreage. Over 3,000,000 acres are currently irrigated in Florida. As of 2012, 1.49 million acres were irrigated in Florida for agricultural purposes.¹ This does not include urban and recreational irrigation. In 2010, approximately 2,551 million gallons of water per day was used for agricultural irrigation with approximately 1,414 of the 2,551 million gallons (55 percent) of water was from groundwater withdrawals and approximately 1,137 million gallons of water per day (45 percent) was from surface water withdrawals.²

Growth in irrigation can be contributed to the limited moisture-holding capacity of some Florida soils, increased scientific knowledge of crop requirements, uneven rainfall distribution, and demand for greater crop intensification. These factors make irrigation more appealing and economical than even before to farmers who have a high investment in crop production. Besides preventing crop-water stress, irrigation systems are used to protect the crop against heat and cold and to apply fertilizers and pesticides.

Due to uneven rainfall distribution and because a large part of the state's agricultural produce is planted, grown, and marketed during fall, winter, and spring (normally the driest part of the year), growers of high-per-acre-value crops find it almost mandatory to provide supplemental irrigation for successful crop production.

¹ United States Department of Agriculture, 2012 Census of Agriculture

² "Water Withdrawals, Use, Discharge, and Trends in Florida, 2010": U.S. Geological Survey Scientific Investigations Report 2014-5088.

Urban irrigation has consistently increased over the years, as more people migrate to Florida and commercial and housing development continues to expand. This has been compounded by the increased use of “water thirsty” varieties of grasses being used on new commercial and housing developments. Many municipalities are now restricting irrigation practices in an effort to conserve a decreasing supply of water. Urban irrigation evaluations provide information necessary to develop a water conservation plan specific to the site.

Sources of water for urban irrigation vary from shallow wells, water utilities, surface water (i.e., ponds, canals, etc.) and re-used resources. Typical irrigation systems consist of subzones of pop-up, sprayer or mister irrigation heads that are controlled independently via manually or electronically operated valves. Over the past 20 years, urban irrigation controllers have continued to improve to include site specific and time specific capabilities as well as automatic shutoff capabilities due to rainfall.

1.2 Mobile Irrigation Lab Technical Handbook

This Florida Mobile Irrigation Lab Technical Handbook (MIL-TH) was prepared by Florida NRCS, in cooperation with FDACS, to provide technical guidance to new and existing MILs regarding their day-to-day operations. The MIL-TH is not intended to replace technical references such as the National Engineering Handbook (NEH) Part 652, Irrigation Guide, Florida Supplement, Chapter 15, but will refer to these and other references as needed.

The MIL-TH:

- provides practical techniques in evaluating irrigation systems and information on new equipment and evaluation methods;
- provides MIL personnel with a ready-reference technical document/working tool; and
- provides consistency in how MILs perform irrigation system

MIL policies, procedures, equipment lists, computer software and sample forms will be developed by the NRCS State Conservation Engineer (SCE) and included in the MIL-TH to provide standard operating procedures for MILs.

Table 1 – MIL Offices and Counties Served

MIL Name	Phone Number	Counties Served	Type ^{1/}
Big Cypress Basin Urban MIL Naples, FL	(239) 455-4100	Collier	U
Broward County (EPD) MIL Ft. Lauderdale, FL	(954) 519-1281	Broward	U
Broward Palm Beach BMP MIL Royal Palm Beach, FL	(561) 792-2727 x 3	Broward, Palm Beach	A
Floridan RC&D MIL St. Augustine, FL	(904) 471-1063	St. Johns, Flagler, Volusia, Putnam	A
Highlands SWCD MIL/ Sebring, FL	(863) 402-7020	Highlands	A
H20 Mobile (Levy SWCD) Trenton, FL	(352) 318-8805	Alachua, Bradford, Union, Taylor, Jefferson. Madison, Hamilton, Suwannee, Gilchrist, Levy, Dixie, Columbia, Marion	A
JEA Lawnsmart Urban (Floridan RC&D) MIL St. Augustine, FL	(904) 471-1063	Duval, Nassau, St. Johns, Clay	U
Lake SWCD MIL Tavares, FL	(352) 343-2481, x 6	Lake, Marion, Orange	A
Lower West Coast MIL Naples, FL	(239) 455-4100	Collier, Hendry, Lee, Charlotte, Glades	A
Manatee County/ Palmetto, Florida	(941) 722-4524	Manatee	U
Miami-Dade SWCD MIL Florida City, FL	(305) 242-1288	Dade, Monroe	A & U
ProMIL (SWFWMD)/ Bradenton, Florida	(941) 920-2458	Manatee	A
Resources Conservation Partners MIL Bell, FL	(850) 766-0736 (386) 209-5301	Alachua, Bradford, Union, Taylor, Jefferson. Madison, Hamilton, Suwannee, Gilchrist, Levy, Dixie, Columbia, Marion	A
SWFWMD MIL Wauchula, FL	(863) 773-4764 x 3	Levy, Marion, Citrus, Lake, Sumter, Hernando, Pasco, Polk, Pinellas, Hillsborough, Highlands, Manatee, Hardee, Sarasota, DeSoto, Charlotte	A
Tampa Bay Estuary MIL/ Plant City, FL	(813) 759-6450, x 3	Hillsborough, Pinellas	A
St. Lucie SWCD Ft. Pierce, FL	(772) 461-4546 x 113	St. Lucie, Martin, Okeechobee, Indian River	A
West Florida RC&D MIL Marianna, FL	(850) 482-0388	Bay, Calhoun, Escambia, Franklin, Gadsden, Gulf, Holmes, Jackson, Jefferson, Leon, Liberty, Okaloosa, Santa Rosa, Wakulla, Walton, Washington	A

^{1/} U = Urban Lab A = Agricultural Lab

Figure 1 – State Water Management District Boundaries

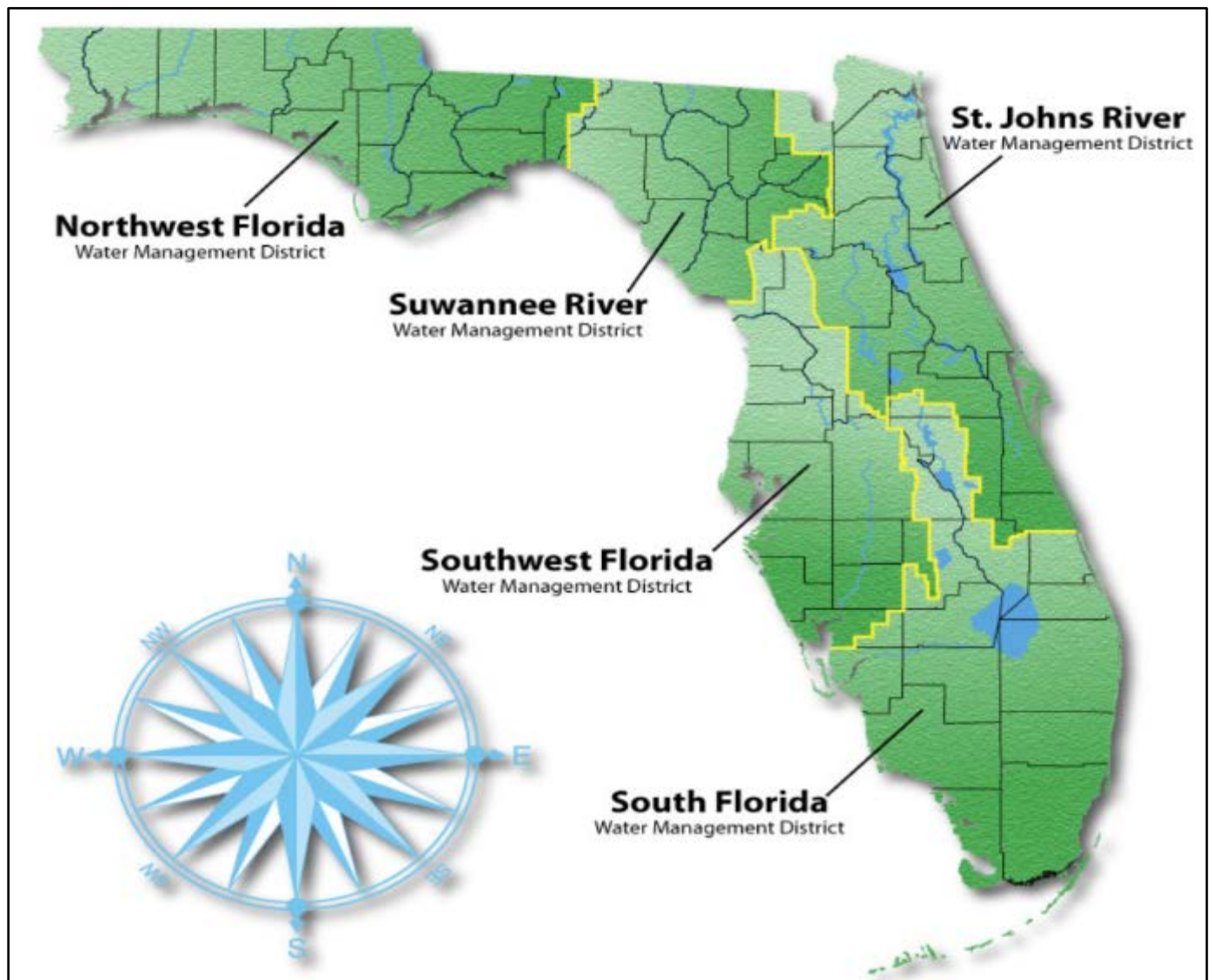

Source: St. Johns River Water Management District, <http://floridaswater.com/maps.html>

Figure 2 – Agricultural MIL Service Area Map

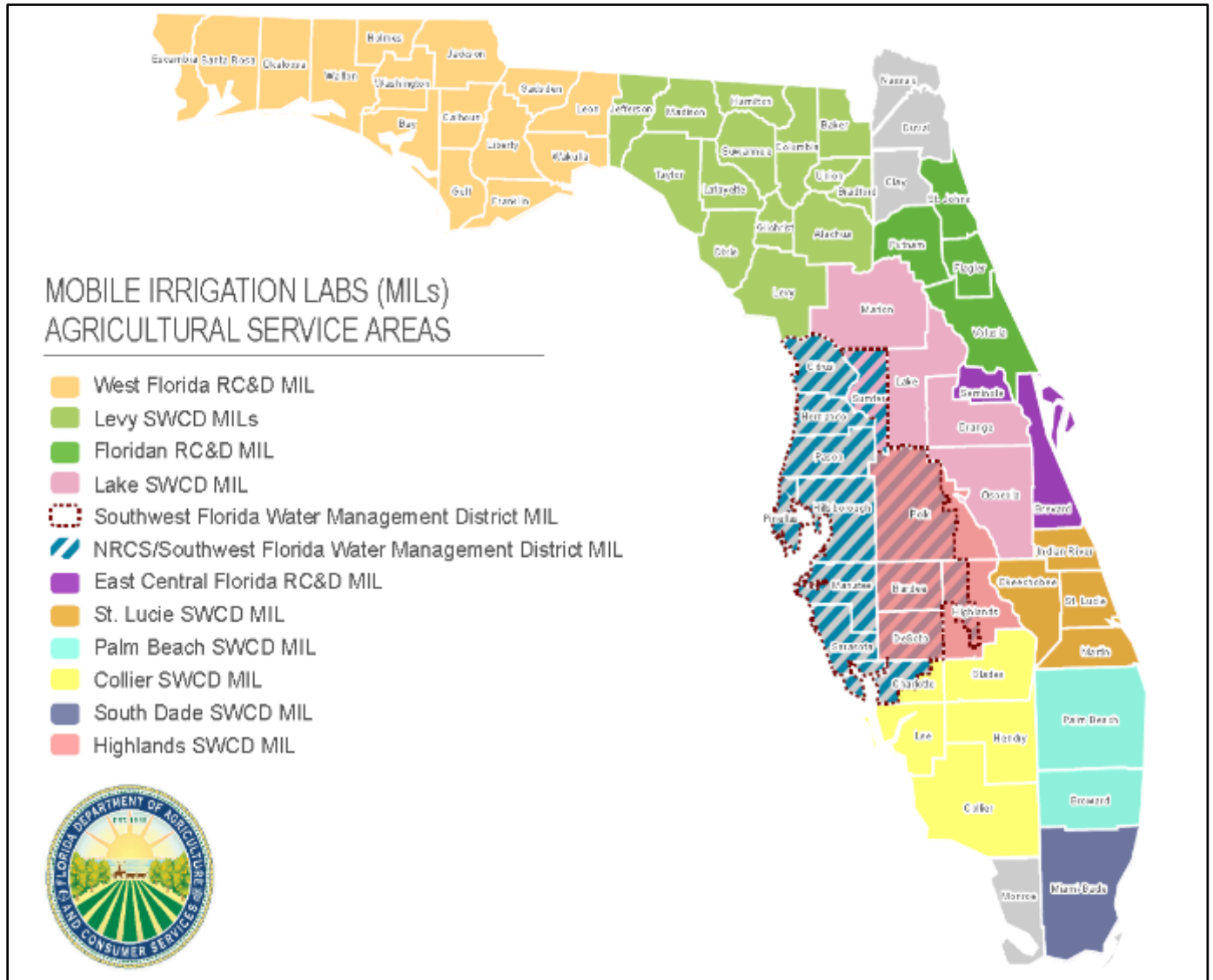

Source: FDACS, Office of Agricultural Water Policy (OAWP),
<http://www.freshfromflorida.com/content/download/26122/502151/file/OAWP%20Mobile%20Irrigation%20Lab%20Service%20Area%20Map.pdf>

Figure 3 – Urban MIL Service Area Map

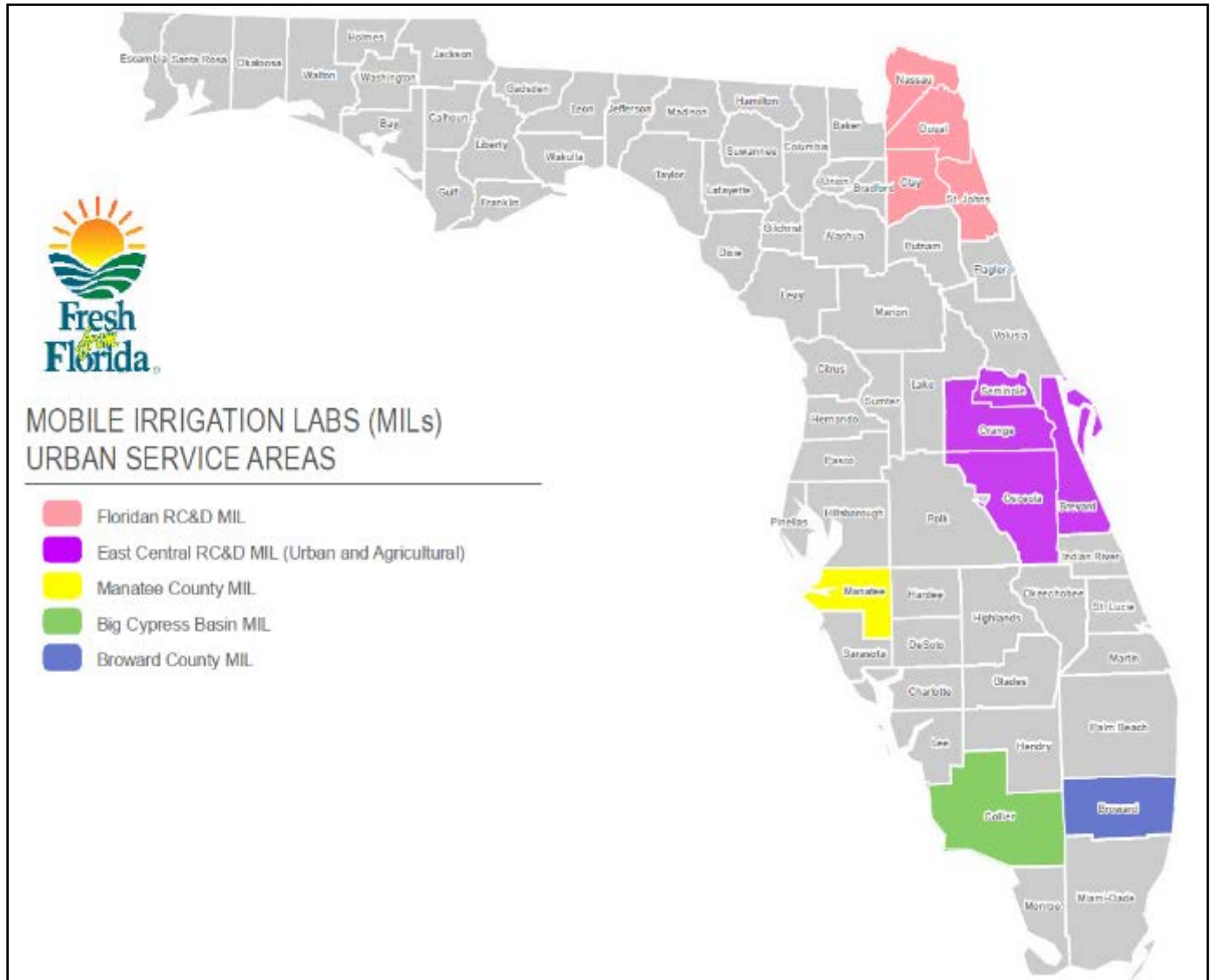

Source: FDACS, Office of Agricultural Water Policy (OAWP),
<http://www.freshfromflorida.com/content/download/26122/502151/file/OAWP%20Mobile%20Irrigation%20Lab%20Service%20Area%20Map.pdf>

Chapter 2 — Irrigation System Evaluations

2.1 Introduction

The major function of the MIL is to evaluate irrigation systems to determine the system efficiency, to provide recommendations for system maintenance, to provide recommendations on proper operation of the system, and to develop a site specific irrigation water management (IWM) plan with the combine result of the efficient use of water resources. IWM plans are prepared in accordance with Florida NRCS conservation practice standard, Irrigation Water Management, Code 449.

Evaluating an irrigation system consists of determining its performance by collecting data and identifying problems any problems that prevent the system from operating at its optimum level. There are several types of irrigation systems, but the process by which they are evaluated is similar for all pressurized pipe irrigation system types. The performance can be determined by the uniformity with which the irrigation water is distributed to the crop and the percentage of the applied water that reaches the crop's root zone.

Before any field evaluation is performed on an irrigation system, the MIL will verify in advance with the irrigator if the irrigation system is in good working condition. If the system is not in good working order, the MIL will not proceed with the evaluation and schedule a future date to perform the evaluation when the irrigation system is operating under normal/typical conditions.

2.2 Performance Terms

The following terms are used to describe irrigation system performance:

Christiansen's Coefficient of Uniformity (CU) – A measure of the uniformity of irrigation water application. The average depth of irrigation water infiltrated minus the average absolute deviation from this depth, divided by the average depth infiltrated. CU is expressed as a percent. The CU value indicates on average how uniform the sprinkler application pattern is. CU gives no indication of how low the uniformity may be for a particular localized area or how large that area might be.

Distribution Uniformity (DU) – A term used for sprinkler systems, it is the uniformity with which the water is distributed over the field surface. Measured with catch cans, it is the ratio of the average amount of water caught in the lowest one-fourth ($\frac{1}{4}$) of the catch cans, to the overall average. DU is expressed as a percent. A DU less than 70% is an indication of poor performance, a DU between 70% and 90% is an indication of good performance and a DU greater than 90% is an indication of excellent performance.

Effective Portion of Water Applied (Re) – The effective portion of water applied is the amount that reaches the soil-plant surface. This is a measurement of the amount of water that evaporates before it reaches the catch cans. For systems with high application rates, the Re should be 1.0, but for systems with low application rates, especially when tested during hot weather, the Re could be less than 1.0.

Emission Uniformity (EU) – A term used to describe the uniformity for microirrigation (drip or microjet) systems. This is the uniformity with which the water is applied to the individual trees or plants. It is a ratio of the average of the low one-fourth ($\frac{1}{4}$) of the emitter discharge rates to the

overall average, expressed as a percent. Emission uniformity is considered excellent above 90%, good 80% to 90%, fair 70% to 80% and poor below 70%.

Potential or Maximum DU or EU Efficiency – This is a measure of the best possible or maximum DU or EU, for each type of irrigation system. Such DUs or EUs have been obtained for several irrigation systems via field testing by the irrigation industry and/or research community over the years. They have also been verified via actual field evaluations conducted by the MILs over the years on different types of irrigation systems. NRCS has compiled a table of maximum DUs or EUs, which can be found in the Florida Supplement to the USDA NRCS NEH, Part 652, Irrigation Guide, Chapter 15, Table FL 15-1, System Potential Efficiencies. This document is located in the FOTG, Section I., C. References, 1. Engineering References, e. Part 652, Irrigation Guide – Florida Supplement, Chapter 15, at the following web address: <http://efotg.sc.egov.usda.gov/treemenuFS.aspx>.

A revised version of maximum DUs or EUs is shown in Table 4 of Chapter 4 of this Handbook. Table 4 reflects updates to the maximum DUs or EUs that the MILs and the Irrigation Conservation Committee (ICC) have reviewed and approved over the years, based on their own evaluation results and/or new industry or research tests and results.

Application Efficiency (E_a) – This is a measure of the efficiency based on the current operating time. It is calculated by dividing the average depth of water stored in the plant root zone by the amount of water applied, diverted or pumped. Application efficiency accounts for all losses between the pump and the irrigated crop, including system leaks, evaporation, spray drift, deep percolation, and runoff.

For subirrigation systems, the application efficiency is estimated by using the NRCS Farm Irrigation Rating Index (FIRI) which considers several system and management factors.

2.3 Farm Irrigation Rating Index

The potential for improving systems for more efficient water use can be determined by field investigations. The real challenge is to develop a viable method for comparing the present irrigation system and management to feasible modifications which result in more efficient irrigation systems and improved management. A good rating system is needed because complete field evaluations are sometimes difficult and require staff time and money which are frequently unavailable.

FIRI was developed using published data for most factors and estimates based on field experience for other factors. FIRI can be tested against field trials and complete field evaluations to refine and improve factors used in the system. FIRI provides a relative rating. It is the product of up to twelve management and system factors to rate consistently from one location to another the effectiveness of irrigation practices. When a potential efficiency is selected for a specific field and irrigation system, the rating will evaluate the difference between the gross volume of farm delivery and the net consumed by the plant. Additional evaluations are required for special water use to determine how efficient the system will apply water for frost protection, waste utilization, fertigation, or chemigation as examples. FIRI represents typical conditions and will only provide a rating for changes. FIRI is not a substitute for detailed irrigation evaluations, but can be used as a tool in determining how the irrigation system and management can be improved.

FIRI can provide an approach to compare the present and future on-farm irrigation consistently by using a standard set of system and management factors. Information from FIRI can be used to provide irrigators:

- (1) on farm irrigation improvements that can be implemented to achieve a specific level of water management and conservation; and
- (2) estimated amount of water conserved when system or management factors are changed.

FIRI provides a uniform and simple method to analyze on farm irrigation water conservation. It provides documentation of the effects of change. It can document effects of annual practices or increments of a conservation plan for a farm tract. The method is the product of the following three elements:

1. The on farm water management – The human element involves decisions which can be scientifically based on measuring water, monitoring soil moisture, and knowing how to operate the irrigation system efficiently. It also involves farmer decisions on a maintenance program, tillage operation, and conservation cropping systems. How the water delivery system is operated also affects decisions on when and how much water to apply. Once a system is in operation, a management plan is required.

The water management element is comprised of six (6) factors applicable to either surface, subsurface, drip/microirrigation, or sprinkler irrigation systems. The factors are as follows:

- Md – Water measurement
 - S – Soil moisture monitoring and scheduling
 - I – Irrigation skill and action level
 - M – Maintenance plan for the system
 - D – Water delivery constraint
 - Sc – Soil condition
2. The on farm irrigation system – For a sprinkler the key system components affecting water conservation are climatic effects, spray type, average wind speed, variation in nozzle pressure, and nozzle selection. Key system components for subirrigation are conveyance, uniformity of water table, capacity to maintain the desirable water table, surface slope, and prevention of tailwater loss. Key components for surface system are conveyance, distribution control, length of run, surface slope and prevention of tailwater reuse.

The irrigation system element is comprised of nine (9) factors. The factors are as follows:

- Wc – Water distribution control factor
- Ce – Conveyance efficiency factor
- L – Land leveling factor
- C – Climatic factor
- Sd – Sprinkler design factor
- W – Wind factor
- R – Tailwater reuse factor
- E – Emitter clogging factor

- T – Drip/microirrigation design factor
3. The potential efficiency of the system – The system “potential efficiency” for an optimally performing unit for the site-specific physical layout can be determined from the National Irrigation Guide (NIG), Part 652, Florida Supplement, Chapter 15, Table FL15-1. For future conditions, a properly designed and installed system utilizing the latest technology is desired.

FIRI can be expressed as an equation to evaluate irrigation systems and water management. FIRI equals the potential efficiency times the system and management factors.

$$FIRI = PE \times SYS \times MGT$$

where:

PE = potential efficiency

SYS = (Wc)(Ce)(L)(R) for surface systems

= (Wc)(Ce)(C)(W)(R) for sprinkler systems

= (Wc)(Ce)(C)(W)(E)(T) for drip/microirrigation systems

= (Wc)(Ce)(C)(W)(E)(T) for drip/microirrigation systems

MGT = (Md)(S)(I)(M)(D)(Sc)

A Microsoft (MS) Excel® worksheet titled “FIRI-FL” has been developed to perform the calculations required in the Farm Irrigation Rating Index. The FIRI-FL worksheet can be downloaded from available for download from the FOTG, Section I., C. References, 1. Engineering References, b. Part 650, National Engineering Field Handbook – Florida Supplement, Chapter 20 – Engineering Software, at the following web address: <http://efotg.sc.gov.usda.gov/treemenuFS.aspx> .

2.4 Evaluation of Microirrigation Systems

The procedure for evaluating microirrigation (drip or microjet) systems is presented in the NRCS NEH, Part 652, Irrigation, Guide, Chapter 9 (Pages 9-163 to 9-173) and the FL NRCS approved *microirreval.xls* computer program. The microirrigation evaluation (Micro-Eval) program uses the procedure in the NEH, performs the calculations, compiles a report, and available for download from the FOTG, Section I., C. References, 1. Engineering References, b. Part 650, National Engineering Field Handbook – Florida Supplement, Chapter 20 – Engineering Software, at the following web address: <http://efotg.sc.gov.usda.gov/treemenuFS.aspx>.

2.4.1 Equipment Required

The equipment required for the field evaluation:

1. 50 ft. tape measure or measuring wheel
2. Pressure gauges (0-60psi) with fittings
3. Stopwatch
4. Graduated cylinder (100 to 1000 ml capacity)
5. 6 ft. soil auger

6. Manufacturer's emitter performance charts showing the relationship between discharge and pressure plus recommended operating pressures and filter requirements.
7. Blank microirrigation evaluation worksheets
8. Portable flow meter

2.4.2 Field Procedure

The following is a description of the field procedure for evaluating microirrigation (drip or microjet) systems.

1. Start the system and let the pressure stabilize (5-10 minutes).
2. Determine if the irrigation system is operating under normal/typical conditions. If the irrigation system is operating under normal/typical conditions, immediately inform the irrigator and reschedule the field evaluation for a future date.
3. Record soil, crop, pump readings (rpm, psi, etc.) and irrigation system data on worksheet printed from Micro-Eval Excel workbook.
4. Check and note the pressure at the inlet and outlet of the filter. On average, there should be no more than 5 psi loss from the inlet end to the outlet end of the filter.
5. Determine from the irrigation decision maker, the frequency and duration of irrigation events he/she currently schedules for the crop.
6. Measure and record the minimum lateral inlet pressure (MLIP) of all the operating manifolds. The MLIP is the lowest pressure in all laterals served by one manifold, measured at the lateral inlet. For level or uphill manifolds, the MLIP is at the far end of the manifold. For downhill manifolds, the MLIP is often at about two-thirds the distance down the manifold. With manifolds on undulating terrain, MLIP generally is located on a knoll or high point. Record these readings on the field sheet or on a drawing for complex irrigation systems.
7. Measure the discharge (for thirty (30) seconds for microjets-sprayers or sixty (60) seconds for drippers) of sixteen (16) emitters, on four (4) laterals on the operating manifold.
8. Enter the amount in milliliters collected on the worksheet. A and B readings may be made at two adjacent emitters if two or more emitters serve one (1) plant. The worksheet is arranged such that the manifold is horizontal across the top of the page, with the pump end on the left. The laterals are vertical, with the top reading being next to the manifold.
9. Measure the inlet and end pressure of the laterals.
10. Measure the wetted area per plant, canopy area, and plant spacing. Use a soil probe, auger, or shovel to estimate the extent (depth) of the wetted area.

2.4.3 Calculations

$$\text{Emitter Discharge Rate, } q \text{ (gph)} = \frac{\text{Catch in ml} \times 0.951}{\text{Seconds}}$$

This is calculated for the 16 emitters.

$$\text{Average Emitter Discharge Rate, } q \text{ (gph)} = \frac{\text{sum of all averages, gph}}{\text{number of averages}}$$

$$\text{Low } \frac{1}{4} \text{ Emitter Discharge Rate, } q \text{ (gph)} = \frac{\text{sum of low } \frac{1}{4} \text{ averages, gph}}{\text{number of low } \frac{1}{4} \text{ averages}}$$

The low quarter (1/4) is lowest four gph measurements, regardless of location.

A discharge correction factor (DCF) is required since the overall system average pressure may be different than the pressure in the manifold where the flow measurements were made. The DCF is a factor to calculate the system average emitter discharge rate from the test manifold average emitter discharge rate.

$$DCF = \frac{2.5 \times \text{average MLIP}}{\text{average MLIP} + (1.5 \times \text{test manifold MLIP})}$$

$$\text{System average discharge rate, gph} = DCF \times \text{manifold average discharge rate, gph}$$

$$\begin{aligned} \text{Test manifold emission uniformity, } EU'm \\ = \frac{\text{low } \frac{1}{4} \text{ emitter discharge rate (gph)}}{\text{average emitter discharge rate (gph)}} \times 100\% \end{aligned}$$

$$\text{Efficiency Reduction Factor (ERF)} = \frac{\text{average MLIP} + (1.5 \times \text{minimum MLIP})}{2.5 \times \text{average MLIP}}$$

$$\text{System Emission Uniformity, } EU' = EU'm \times ERF$$

$$\text{Potential Application Efficiency, } PELq = \frac{EU'}{T_R (1 - LR_t)}$$

Where T_R = Transpiration ratio, NEH Part 623, Chapter 7, Table 7-15. This ratio estimates losses due to untimely rainfall and variations in the soil.

LR_t = Leaching requirement ratio, NEH Part 623, Chapter 7, Equations 7-22 and 7-23. NEH Part 623, Chapter 7, Figure 7-75 provides a graphical solution for Equations 7-22 and 7-23. This is to be considered if harmful soluble salts need to be removed from the root zone.

2.4.4 Analysis of Evaluation Results

The level of performance of microirrigation systems is indicated by the potential and application efficiency. A low potential efficiency indicates physical problems with the system, while low application efficiency indicates inaccurate scheduling. It is an economic decision whether the level of performance of a system is acceptable or whether improvements should be made.

If the level of performance is not acceptable, then the cause of the low efficiency must be determined. Through the evaluation process and detailed note keeping, the problems with the system can be identified. Florida NRCS conservation practice standards Irrigation System, Microirrigation, Code 441 and Irrigation Pipeline, Code 430 establishes a basis for comparison and help identify less than acceptable system components.

The main factor that determines system performance is emitter discharge rate variation throughout the system. NRCS specifications allow no more than a twenty (20) percent variation of the design flow rate. Since flow rates are dependent on pressure, pressure variation will affect performance. Pressure should not vary more than 30% throughout the system. The following table lists specific test results, possible problems and possible solutions.

2.4.5 Typical Problems and Recommendations for Microirrigation Systems

Table 2 – Test Results, Problems, and Solutions for Microirrigation Systems

Test	Problems	Solution
Pressure at pump	Low pressure	Check pump specifications
	< 30 psi	Change pump
	Small wetted area	Use smaller jets
	Clogging	Use smaller zones
	Elevation effects	Use higher rpm
	High pressure	Use larger jets
	Low fuel efficiency	Use larger zones
	caused by clogging	Use pressure regulators
Filter inlet/outlet pressure	> 5psi difference	Clean or replace filter
Pressure between pump and first manifold (deadhead)	> 5psi difference	Use larger pipeline
		Rezone
		Increase rpm
		Check valves
Pressure between manifolds	> 2-3 psi difference	Rezone
		Control with valves
		Use larger pipe
Pressure between laterals	> 2-3 psi difference	Use additional manifolds
		Use pressure regulators
Pressure variation in lateral	> 2-3 psi difference	Use additional manifolds
		Use smaller emitters
		Use higher pressure if elevation change
		Use larger tubing
Emission Uniformity	< 90%	Use same brand and type of emitter
		Clean emitters

The following list describes typical microirrigation system problems and possible solutions.

1. Low System Pressure – The overall pressure found in the system is lower than normally used in this type of system. The pressure could be increased by irrigating smaller or fewer zones at one time or by increasing pump rpm.
2. Filter Clogged – The pressure loss was higher than normally seen for this type of filter. The filter should be flushed and the screen cleaned. If cleaning the filter does not reduce the pressure loss, then check the pressure gauges for accuracy and install a higher capacity filter if necessary. Screen filters usually have no more than 5 psi loss between the inlet and outlet.
3. Mainline Pressure Loss – Excessive pressure losses were found in the mainline. This reduces efficiency, since a higher pumping head is required to deliver adequate pressure to the emitters. Possible solutions are to divide the flow between mainlines by changing the zones that are operated at one time or to install additional mainlines.
4. Different Pressures between Manifolds – The average pressure varied between the submains. Adjustable field valves should be installed or existing valves should be used to equalize pressure between submains to make pressure and flow more uniform throughout the system.
5. Poor Emission Uniformity – Poor emission uniformity reduces the system efficiency since some of the trees will receive insufficient water while some will be over-irrigated. Emission uniformity is especially important if fertigation is being used. Excellent uniformity would be 90% or above.
6. Clogged Emitters – Many emitters were clogged, especially at the ends of the lateral lines. Clogging can be reduced by flushing the laterals more often, or in severe cases, injecting chlorine, with the injection program based on sulphide and iron concentrations and pH.
7. Mixed Emitters – Emitters with differing discharge rates are being used. The system design should be reviewed to determine the correct discharge rate and number of emitters to use. It is important to use the correct emitter to allow good pressure and flow distribution for a particular pipe design. It is usually good to use one model of emitter throughout the system, since different models and makes could have different flow rates.
8. Poor Emitter Uniformity – A variation was found in the discharge rate between emitters operating at the same pressure. This is caused by variation in the emitters themselves. If this variation is unacceptable then the emitters should be replaced with new emitters of uniform operating characteristics.
9. Broken Pipes – Cuts and breaks were found in the lateral lines. Even small leaks can significantly reduce pressure in downstream sections. Repairing breaks will improve discharge uniformity and increase overall pressure.
10. Valves Not Opening – It appears that the control valves are not opening completely. A pressure differential was found upstream and downstream from the valves.
11. Pressure Regulators Not Functioning – The pressure regulators are not maintaining the downstream pressures within a satisfactory range. This is caused by some regulators malfunctioning or not having the required inlet pressure.

12. Submain Pressure Loss – Pressure was lost in the submains due to inadequate pipe size. The system design should be checked to determine the most practical way to reduce losses. Alternatives include using smaller emitters to reduce flow, installing more submains or using pressure regulators.
13. Lateral Pressure Loss – The tubing is improperly sized for the number and size of emitters that are being used, causing an excessive loss of pressure near the end of the tube. The system design should be checked to determine the best alternative for reducing losses. Possibilities include using larger tubing, lower discharge emitters or additional submains.
14. Elevation Effects – Pressures and discharge rates varied due to differences in elevation. The system design should be checked to determine the best way to compensate for elevation and to equalize pressure. Alternatives include using pressure regulators or gate valves to reduce pressure in higher pressure areas and installing additional submains to increase pressure in lower pressure areas.
15. Small Irrigated Area – A small percentage of the field area was covered by irrigation. When a small area of soil is available to hold irrigation water, frequent, short irrigations are required. With extremely small wetted areas, the soil in this area may not be able to hold sufficient water to meet the crops needs. By installing emitters with a larger area of coverage, longer operating times could be used, the times between irrigations could be increased and the water will be more readily available to the crop. It is recommended that at least 33% of the field area be covered. If drip system is to be converted to a spray jet system, a complete redesign is necessary.
16. Emitter Integrity – Worn or missing emitters can greatly reduce the efficiency of an irrigation system. With worn emitters, they may not be able to provide the required flow rate for plant survival or they do not work at all. Missing emitters on the other hand may provide too much water which can lead to plant damage or disease. By installing new emitters the survival rates for the plants should be improved. When replacing emitters it is not recommended to not mix and match emitter types as this too could lead to a less efficient irrigation system.

2.5 Evaluation of Sprinkler Irrigation Systems

The evaluation of sprinkler systems is based on a test of the pressure throughout the system and a measurement of the uniformity with which the water is distributed over the field surface.

The recommended procedure for evaluating sprinkler irrigation (center pivot, lateral move, traveling gun, periodic move or solid set) systems is presented in the NRCS NEH, Part 652, Irrigation Guide, Chapter 9 (Pages 9-119 to 9-162).

2.5.1 Evaluation of Fixed and Portable Lateral Sprinkler Systems (Solid Set and Linear Move)

The FL NRCS solid set evaluation (SPR-SS-Eval) program (*spr-ss-eval_ver_1.1.xls*) uses the procedure in the NEH, performs the calculations, compiles a report, and is available for download from the FOTG, Section I., C. References, 1. Engineering References, b. Part 650,

National Engineering Field Handbook – Florida Supplement, Chapter 20 – Engineering Software, at the following web address: <http://efotg.sc.e.gov.usda.gov/treemenuFS.aspx>.

2.5.1.1 Equipment Required

The equipment required for the field evaluation:

1. Pressure gauge (0-100 psi) with pitot tube attached
2. Stopwatch
3. A large container of known volume clearly marked (1 gallon or larger)
4. A 4-ft hose having a diameter appreciably larger than the outside diameter of nozzles
5. Catch containers
6. 500 ml graduated cylinder to measure volume of water caught in containers
7. Soil probe
8. Shovel
9. 100-ft tape measure
10. Wind velocity gauge
11. Rain coat, rubber boots
12. Manufacturer's sprinkler performance charts, when made available by irrigator or irrigation vendor and when irrigator has received government cost share.
13. Set of drill bits

2.5.1.2 Field Procedure

The following is a description of the field procedure for evaluating fixed solid set and portable lateral sprinkler systems.

1. Select the field location for the evaluation. Field location should be a location at which the pipe pressure is representative of the entire system. If the pipe diameter is the same throughout the entire lateral, about half the pressure loss resulting from pipeline friction loss in that lateral occurs in the first 20 percent of the length. Over 80 percent of pressure loss occurs in the first half of the lateral length. On a flat field, the most representative pressure occurs about 30 to 40 percent of the distance from the lateral inlet to the terminal end.
2. Measure and record sprinkler spacing.
3. Obtain and record duration and frequency of irrigation from operator.
4. Record Management Allowable Depletion (MAD) as described in the NEH, Part 652, Irrigation Guide, Florida Supplement, Chapter 4, Water Requirements, if available.
5. Locate catch containers as shown in Figures 4a and 4b. The containers should be evenly spaced between two adjacent laterals for solid set systems. Any surrounding vegetation that would interfere with a container should be removed.

Figure 4a – Example Solid Set Catch Can Layout

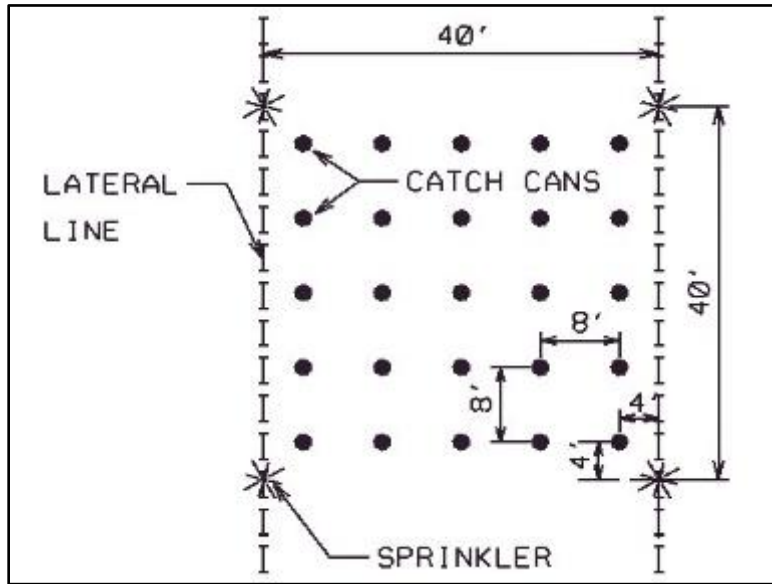

Spacing catch cans: Divide sprinkler spacing by number of cans (row or column). If the answer is a whole number, this will be the spacing between cans. One-half of this number will be the spacing between the sprinkler and the first can.

If the answer is not a whole number, round down for can spacing and divide the remaining length in half, for spacing between the sprinkler and first can. For example, if spacing is 34 feet and there will be 5 rows of cans, $34/5 = 6.8$. Spacing between cans will be 6 feet. Spacing between the cans is 34 feet minus the sum of the spacings between cans (24 feet in this case) = 10 feet. Divide the 10 feet by 2 to determine the spacing between the sprinkler and the first can ($10/2 = 5$ feet).

Figure 4b – Example Solid Set Catch Can Layout

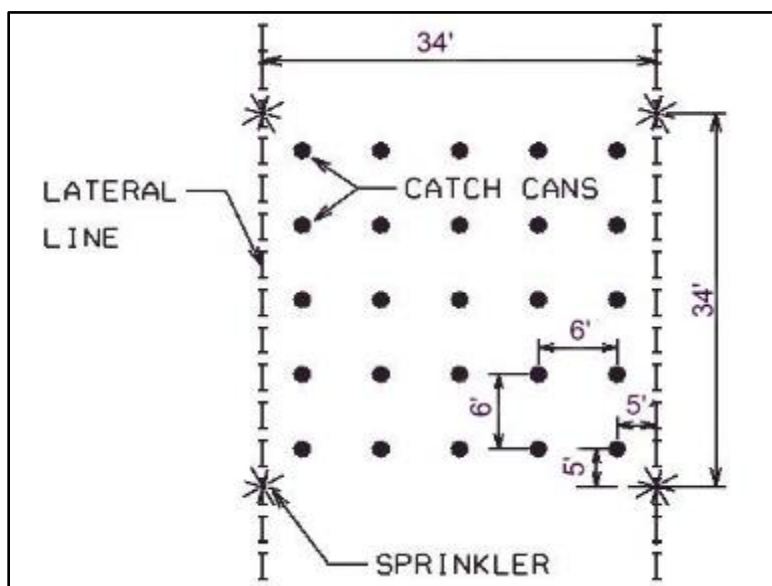

6. Check and record make and model of sprinklers and diameter of nozzles.
7. Record rated sprinkler discharge, pressure and design application rate from manufacturer's charts.
8. Check and record the size and slope of lateral lines and the height of risers.
9. Temporarily turn sprinklers that will irrigate the catchment area, away from catchment area. To do so, block sprinklers by wedging a short piece of wire or stick behind the swinging arm.
10. Set a known amount of water (in the same type of container as the catch containers) outside the catchment area to measure the approximate volume of water lost to evaporation.
11. Turn on water to fill lateral lines.
12. Measure pressure and discharge rates at sprinklers that are going to irrigate the catchment area.

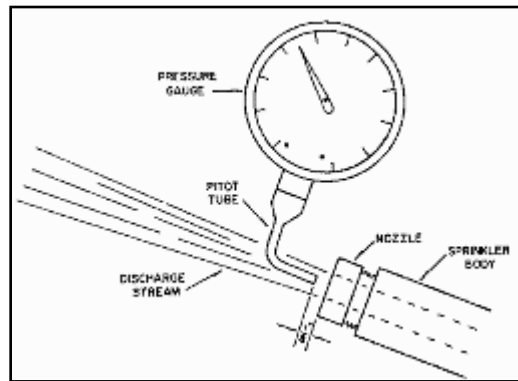

13. Remove wire or stick from sprinklers that are going to irrigate the catchment area, and start test time.
14. While test is in progress, measure pressure and discharge rates at random sprinklers within the system.
15. Note wind speed and direction.
16. Operate the system long enough to catch a measurable amount of water. End test and record time.
17. Measure and record catch volumes.
18. Measure and record evaporation.

The Sprinkler Irrigation System Evaluation Form can be found in the NRCS Irrigation Guide, Chapter 15, pages 15-73 to 15-78. The form is set up for transposing catch data. Adjustments in computations are required if data are not transposed when adjacent laterals are operating.

2.5.1.3 Calculations

1. Convert volumes of water caught to rates (in./hr.).

$$\text{Catch Can Conversion Factor} = \text{ml/in} = \text{Area of top of can, in}^2 \times 16.39 \text{ ml/in}^3$$

$$\text{Application Rate, in/hr} = \frac{\text{Catch, ml}}{\text{Catch can factor, ml/in} \times \text{Duration, hr}}$$

After performing the catch can test, the average catch is calculated by adding the amount caught in all containers and dividing by the number of containers. The amount of evaporation is added to this average and the result is divided by the catch can conversion factor to give the average catch rate.

2. Compute and evaluate Distribution Uniformity (DU) and Christiansen's Uniformity (CU) coefficient.

$$DU = \frac{\text{Average catch low } \frac{1}{4} \text{ composite containers}}{\text{Average total catch}} \times 100$$

$$CU = 100 - 0.63 \times (100 - DU)$$

3. Determine system DU and CU.

$$\text{System } DU = DU \times \left(1 - \frac{P_x - P_n}{5P_a}\right)$$

$$\text{System } CU = CU \times \left(1 - \frac{P_x - P_n}{8P_a}\right)$$

Where:

P_x = the maximum sprinkler pressure (psi)

P_n = the minimum sprinkler pressure (psi)

P_a = the average sprinkler pressure (psi)

4. Calculate gross application rate per test.

$$\text{Average Application Rate, in/hr} = \frac{\text{Sprinkler discharge rate, gpm} \times 96.3}{\text{Lateral Length, ft} \times \text{Lateral Spacing, ft}}$$

If a flow meter is present in the system, the average sprinkler discharge rate can also be determined by dividing the total system flow rate by the number of sprinklers.

R_e = Effective portion of applied water to ground

$$R_e = \frac{\text{Average catch rate}}{\text{Average Application rate}}$$

Application Efficiency of Low Quarter, Eq (%)

$$Eq = DU, \% \times R_e$$

2.5.2 Evaluation of Traveling Gun Sprinkler System

2.5.2.1 Equipment Required

1. Catch containers and stakes
2. 50 ft. measuring tape
3. 500 ml graduated cylinder
4. Pressure gauge (0-160 psi)
5. Inside diameter measurement calipers
6. Soil auger, push tube sampler, probe, shovel
7. Stopwatch
8. Wind velocity gauge
9. Thermometer to measure air temperature
10. Manufacturer's sprinkler head performance charts, when made available by irrigator or irrigation vendor and when irrigator has received government cost share.

2.5.2.2 Field Procedure

The following is a description of the field procedure for evaluating traveling gun sprinkler systems.

1. When available obtain sprinkler gun specifications from the manufacturer, including operating pressures, nozzle type, inside diameter of nozzle, and system speed.
2. Record system information including the condition of the unit, operating pressure at pump and nozzle, the size of the nozzle, and the crop(s) being irrigated.
3. Record size and length of hose.
4. Record the make and model of the sprinkler.
5. Record the make and model of the traveler.
6. Document any wet/dry areas in the field.
7. Document any erosion or runoff.
8. Record the size of risers and pipe.
9. Estimate soil water deficit in field, both ahead of and behind traveler.
10. Note depth to water table, apparent root development, and any root and water movement restriction.
11. Select evaluation site that is representative of field and ahead of traveler.
12. Measure system flow rate at the beginning and end of the evaluation.
13. Observe system operating pressure from the ground. Do not climb up unit while operating.

The Sprinkler Irrigation System Evaluation Form can be found in the NRCS Irrigation Guide, Chapter 15, pages 15-89 to 15-93. A fillable version of the Sprinkler Irrigation System Evaluation Form can be for download from the FOTG, Section I., C. References, 1. Engineering References, b. Part 650, National Engineering Field Handbook – Florida Supplement, Chapter 20 – Engineering Software, at the following web address:
<http://efotg.sc.egov.usda.gov/treemenuFS.aspx>.

2.5.3 Evaluation of Center Pivot Sprinkler System

2.5.3.1 Equipment Required

1. Catch containers and stakes

$$No. Needed = \frac{Lateral\ length + 10}{Catch\ Container\ Spacing}$$

2. 300 ft. measuring tape
3. 500 ml graduated cylinder
4. Pocket tape (inches)
5. Diameter tape
6. Pressure gauge with pitot tube (0-100 psi)
7. Flow measuring device
8. Ohmmeter or electrical ground check meter to measure salinity
9. Soil auger, push tube sampler, probe, shovel
10. Equipment for determining soil moisture
11. Stopwatch
12. Thermometer to measure air temperature
13. Wind velocity gauge
14. Ladder
15. Raincoat, rubber boots
16. When available, obtain printout of manufacturer's pivot design (for use in field and office)

2.5.3.2 Field Procedure

The following is a description of the field procedure for evaluating center pivot sprinkler systems.

1. Select an evaluation site that is representative of the field.
2. Obtain end gun specifications from the manufacturer, including model and capacity.
3. Obtain a certified copy of sprinkler package from the irrigator or irrigation designer and verify sprinklers have been installed as specified in the sprinkler package.
4. The system pressure shall match pressure used to design the sprinkler package.
5. The end gun shall be operated in the same operational mode as specified in the sprinkler package.

6. Record system information including the condition of the unit and the crop(s) being irrigated.
7. Determine flow into system. If ultrasonic flow meters are used, ensure the pipeline is flowing full at the location of the meter and that there is adequate distance of straight pipe, free of obstructions, upstream from the point of flow measurement.
8. Determine operating pressure at the beginning of the system.
9. Record wind speed and direction, and air temperature.
10. Set catch containers along radius from pivot at a spacing of ≤ 30 feet. Omit placing them under the first one or two spans. Level the containers. Extend the containers beyond the wetted area. Avoid the tower wheels.
11. Set a known amount of water (in the same type of container as the catch containers) outside the catchment area, to measure the approximate volume of water lost to evaporation.
12. Allow the wetted area to completely pass over the catch containers.
13. Measure water caught in the catch containers.
14. Reference the evaporation lost in the evaporation container.
15. Weight the catches.

$$\text{Weighted Low } \frac{1}{4} \text{ Average Application Depth} = \frac{\text{Sum Low } \frac{1}{4} \text{ weighted catches}}{\text{Sum Low } \frac{1}{4} \text{ position numbers}}$$

The Sprinkler Irrigation System Evaluation Form can be found in the (NEH) Part 652, Irrigation Guide, Florida Supplement, Chapter 15, pages 15-81 to 15-88. The form is set up for transposing catch data. Adjustments in computations are required if data are not transposed when adjacent laterals are operating. A fillable version of the Sprinkler Irrigation System Evaluation Form can be for download from the FOTG, Section I., C. References, 1. Engineering References, b. Part 650, National Engineering Field Handbook – Florida Supplement, Chapter 20 – Engineering Software, at the following web address: <http://efotg.sc.e.gov.usda.gov/treemenuFS.aspx>.

2.5.4 Analysis of Sprinkler System Evaluations (Solid Set, Linear Move, Traveling Gun, and Center Pivot)

The level of performance of sprinkler systems is indicated by the potential efficiency and application efficiency. A low potential efficiency indicates physical problems with the system, while low application efficiency indicates inaccurate scheduling. Ultimately, it is an economic decision whether the level of performance of a system is acceptable or whether improvements should be made.

If the level of performance is not acceptable, then the cause of the low efficiency must be determined. Through the evaluation process and detailed note keeping, the problems with the system can be identified. Florida NRCS conservation practice standards Sprinkler System, Code

442 and Irrigation Pipeline, Code 430 establish a basis for comparison and help identify less than acceptable system components.

The two (2) main factors that determine system performance are pressure variation and sprinkler spacing. NRCS specifications allow no more than a 20% variation in pressure among sprinklers, and a sprinkler spacing no more than 25% of the wetted diameter for fixed position spray sprinklers, 40% of the wetted diameter for rotating or oscillating sprinklers, and 50% of the wetted diameter for impact sprinklers. Base the wetted diameter on manufacturer's information for the design nozzle height and pressure.

The average system pressure should be high enough to break up the water discharge stream, normally 40 psi or higher. For low pressure systems the average system pressure should be 40 psi or lower, unless specified by manufacturer. Nozzle sizes should be uniform throughout the system. In small fields, partial circle nozzle heads may be used to adequately cover the edge of the field. In this case, application rates should be matched for the sprinklers. For example, 180 degree sprinklers should have one half ($\frac{1}{2}$) the discharge rate of the 360 degree sprinklers.

2.5.5 Typical Problems and Recommendations for Sprinkler Irrigation Systems

Table 3 – Test Results, Problems and Solutions for Sprinkler Systems

Test	Problems	Solution
Pressure at pump	Low pressure	Check pump specifications
	< 40 psi (poor coverage)	Change pump
		Use smaller nozzles
		Use smaller zones
		Use higher rpm
	High pressure	Use larger nozzles
60 psi	Use larger zones	
Filter inlet/outlet pressure	> 5 psi difference	Clean or replace filter
Pressure between pump and first manifold (deadhead)	> 10 psi difference	Use larger pipeline
		Rezone
		Increase RPM
		Check valves
Pressure between submains	> 4-6 psi difference	Rezone
		Control with valves
		Use larger pipe
Pressure between laterals	> 4-6 psi difference	Use additional submains
		Use pressure regulators
Pressure variation in lateral	> 4-6 psi	Use additional submains
		Use smaller nozzles
		Use pressure regulators
Sprinkler spacing	> 65% of wetted diameter	Increase pump rpm
		Redesign system
Sprinkler discharge	> 20% variation	Use same brand and type of sprinkler
		Clean or replace nozzles
		Clean screens
End gun	Out of adjustment or not operating	Adjust the end gun position or repair end gun
	Boot Leak	Repair boot leak
	No booster pump	Install booster pump
Distribution uniformity	< 60%	Adjust sprinklers
		Increase pressure
		Change sprinkler type
		Redesign system
Control box	Malfunctioning	Replace control box

The following list describes typical sprinkler system problems and possible solutions.

1. Low System Pressure – The overall pressure found in the system is lower than normally used in this type of system. To produce uniform coverage, sprinklers require high pressure to break up the discharged stream of water. The sprinkler manufacturer usually will provide a recommended pressure range for each sprinkler. Usually the minimum pressure is 40 psi. Increasing pressure could improve the spray pattern and the uniformity of coverage. The pressure could be increased by irrigating smaller or fewer zones at one time or by increasing pump rpm.
2. Filter Clogged – The pressure loss was higher than normally seen for this type of filter. The filter should be flushed and the screen cleaned. If cleaning the filter does not reduce the pressure loss, then check the pressure gauges for accuracy and install a higher capacity filter if necessary. Screen filters usually have no more than 5 psi loss between the inlet and outlet.
3. Mainline Pressure Loss – Excessive pressure losses were found in the mainline. This reduces efficiency, since a higher pumping head is required to deliver adequate pressure to the sprinklers. Possible solutions are to divide the flow between mainlines by changing the zones that are operated at one time or to install additional mainlines.
4. Different Pressures Between Manifolds – The average pressure varied between the manifolds/submains. Valves should be installed or existing valves should be used to equalize pressure between manifolds/submains to make pressure and flow more uniform throughout the system.
5. Wide Spacing – The sprinkler spacing is wide for the diameter of coverage of these sprinklers. Sprinklers should have close to head to head coverage when pressure is correct. The system design should be reviewed to determine nozzle, pressure and spacing alternatives that would produce better spray pattern overlap.
6. Poor Distribution Uniformity – The distribution uniformity is a measurement of how uniformly the water is applied over the field surface. Poor distribution uniformity reduces the system efficiency since some of the plants will receive insufficient water while some will be over-irrigated. The uniformity should increase if the pressure is increased. Occasionally sprinklers will have poor uniformity even with adequate pressure and spacing. Check the sprinkler for adjustments.
7. Broken Sprinklers – Many sprinklers had broken arms or nozzles.
8. Mixed Nozzle Sizes – Nozzles with differing discharge rates are being used. The system design should be reviewed to determine the correct nozzle to use. It is important to use the correct nozzle to allow good pressure and flow distribution for a particular pipe design and to provide adequate spray pattern overlap. The nozzles should also be matched. All 360 degree sprinklers in a system should have the same nozzle size. 180 degree sprinklers should have a nozzle size to produce ½ of the 360 degree discharge rate. Check the original design and replace nozzles.
9. Poor Sprinkler Uniformity – A variation was found in the discharge rate between sprinklers operating at the same pressure. This is caused by variation in the sprinklers or nozzles themselves, possibly due to wear. If this variation is unacceptable then the sprinklers should be replaced with new sprinklers of uniform operating characteristics.

10. Broken Pipes – Breaks were found in the pipelines. Even small leaks can significantly reduce pressure in downstream sections. Repairing breaks will improve discharge uniformity and increase overall pressure.
11. Valves Not Opening – It appears that the control valves are not opening completely. A pressure differential was found upstream and downstream from the valves.
12. Pressure Regulators Not Functioning – The pressure regulators are not maintaining the downstream pressures within a satisfactory range. This is caused by some regulators malfunctioning or not having the required inlet pressure.
13. Submain Pressure Loss – Pressure was lost in the submains due to inadequate pipe size. Pressure variation is sometimes caused by partially closed valves or clogging of the sprinkler screens. The system design should be checked to determine the most practical way to reduce losses. Alternatives include using smaller nozzles to reduce flow, installing more submains or using pressure regulators.
14. Lateral Pressure Loss - The lateral pipes are improperly sized for the number and size of sprinklers that are being used, causing an excessive loss of pressure near the end of the lateral. The system design should be checked to determine the best alternative for reducing losses. Possibilities include using lower discharge nozzles or additional submains.
15. Elevation Effects – Pressures and discharge rates varied due to differences in elevation. The system design should be checked to determine the best way to compensate for elevation and to equalize pressure. Alternatives include using pressure regulators or gate valves to reduce pressure in higher pressure areas and installing additional submains to increase pressure in lower pressure areas.
16. Blocked Sprinklers – Sprinkler performance will be affected if the sprinkler stream is blocked. The sprinkler should be above the crop vegetation or should be a low-trajectory type if under-tree or in a greenhouse.
17. Clogged Sprinklers – The nozzles or screens in the sprinklers were clogged. Remove and clean the nozzle or screens. Check the water supply and install a filter if the water contains particles larger than the sprinkler nozzle.
18. Boot Leak – A Boot is approximately an 18 inch piece of flexible material connecting each tower to allow the pivot to flex with the terrain. If the boot is leaking we recommend that they replace the boot.
19. Pipe Joint Leak – A section of the overhead pipe is connected and each connection has a rubber gasket. If the pipe joint is leaking the gasket has to be replaced.

2.6 Evaluation of Subirrigation Systems (Flow Through and Underground Conduit)

Successful operation of subirrigation systems requires that the water table be maintained at a uniform depth below the ground surface so that moisture can be supplied to plants through capillary movement (upward flux). The water table is regulated by controlling drainage to manage the removal of subsurface and surface water and by providing irrigation water as needed to maintain the water table high within an acceptable range to provide adequate moisture to the

crop. A drainage system is essential to remove excess surface water and subsurface water, so that the water table does not remain in the root zone for long periods so as to cause crop damage.

Information gathered should include both management factors as well as irrigation system factors. Management factors include whether or not water measurement devices are used (Md), method used to determine when to irrigate (S) (soil moisture monitoring and scheduling procedure), irrigation skill and action level (I), the condition of the system (M) (maintenance), the ability of the system to provide irrigation water when needed (D), soil condition (Sc). System factors include the type of conveyance system used (Wc), the capacity of the delivery system (D), land leveling factor (L), tailwater recovery systems (R), climatic factor (C), wind factor (W), sprinkler design factor (Sd), emitter clogging factor (E), and drip/microirrigation design factor (T).

These factors are discussed in detail in "Farm Irrigation Rating Index (FIRI)", (NEH) Part 652, Irrigation Guide, Florida Supplement, Chapter, Chapter 15, FL652.1501. The FIRI worksheet can be downloaded the FOTG, Section I., C. References, 1. Engineering References, b. Part 650, NEH – Florida Supplement, Chapter 20 – Engineering Software, at the following web address: <http://efotg.sc.egov.usda.gov/treemenuFS.aspx>. The necessary data can be obtained by interviewing the irrigator and by making observations and measurements.

For subirrigation the key system components are conveyance, uniformity of water table, capacity to maintain the desirable water table, surface slope, and prevention of tailwater loss. A system "potential efficiency" above 75% is considered good for a subirrigation system. For future conditions, a properly designed and installed system utilizing the latest technology is desired.

This section describes how to perform and evaluate both *general* and *detailed* evaluations of subirrigation systems. It is recommended that detailed evaluations be performed in order to gain knowledge and experience of how subirrigation systems perform under different management techniques, soil types, crops, etc., and when time and equipment are available.

General field evaluations will normally be performed when information is available on the system and/or when time and equipment are not available. These evaluations are qualitative and often provide the necessary information for identifying and correcting problems of the system layout and of its operation.

Detailed field evaluations are quantitative and provide more detailed data required for recommending changes, for making economic comparisons, and for furnishing background data for design of systems operating under similar conditions.

2.6.1 Equipment Required

The equipment required for the *general* field evaluation:

1. Soils auger for verifying soil type and installing water table wells (cased or uncased).
2. Stopwatch or watch with easily visible second hand for timing irrigation inflows and outflows.
3. Measuring tape to measure water table depth and furrow spacing.

4. Flow measurement equipment.
5. Soil moisture sensor.
6. Survey equipment for checking irrigation slope.

Equipment required for the *detailed* field evaluation includes the same equipment required for *general* evaluation plus:

1. Flow measuring devices such as small Parshall flumes, orifice plates, flow meters, large Parshall flumes, and/or calibrated containers. Devices must be capable of measuring head or recording velocity of flow.
2. Equipment for determining soil moisture may be desirable.
3. Stage recorders may be necessary.
4. Soil Moisture Sensor.
5. Cased observation wells.

2.6.2 Field Procedure

The following describes information to be gathered for the field procedure for a *general* field evaluation.

1. Estimate water loss in the delivery system (if open ditches).
2. Determine or verify soil type. Include areas where irrigator has observed abnormal conditions.
3. Determine from irrigator and by observation, wet and dry locations in the field. (Points that wilt early and areas where plant's response indicates wet areas).
4. Choose typical locations (furrows) in fields to be evaluated. A minimum of three (3) furrows shall be evaluated in a management zone. Locations shall include wet and dry points that contain a significant area (greater than 10 percent of the management zone).
5. During the irrigation cycle, record furrow inflow (gpm), length, slope, spacing, and depth.
6. Observe the runoff (tailwater) in furrows or mains and record observations. Estimate the rate, length of time, and amount of tailwater loss.
7. During the irrigation cycle, two (2) water table depths shall be measured at each location evaluated. The water table depth shall be recorded at points $\frac{1}{4}$ and $\frac{3}{4}$ along the furrow length, midway between the furrows. The measurements should be taken when the irrigation stream is at least midway along the furrow. Measure the elevation difference between the water table and the bottom of the furrow.
8. Observe drainage characteristics of the system. If inadequate, discuss with the irrigator.
9. Check erosion throughout the system (furrows, drainage mains and laterals).
10. Estimate total water available for irrigation.

Information to be gathered for the field procedure of a *detailed* field evaluation includes the same as for *general* field evaluation but may also include:

1. Actual measurement of water loss in delivery system or portions of the system.
2. During the irrigation cycle, record hourly water table response, i.e., depth and time to rise in observation wells.
3. Measure lateral (furrow) inflow and hourly outflow for 24 hours or one irrigation cycle, when water is fluctuating.
4. Measure tailwater losses from the management zone when possible, or selected furrows, for 24 hours or longer.
5. In addition to survey data for general evaluations, survey to determine:
 - a. Elevations of water control structures.
 - b. Capacity of water control structures.
 - c. Capacity and adequacy of surface drainage system.
6. Determine water flow into the system. Where possible measure pump discharges or water flow in open channels, or use other data such as pump curves, meter readings, etc.
7. Use FIRI to rate the irrigation system.

2.6.3 Analysis of Subirrigation System

1. Analyze to determine if total water available is sufficient to meet the crop's peak consumptive use.
2. Check variation in water table depth and water table response. When stabilized, the water table depth from the top of the bed should not vary more than 0.5 feet within a management zone. When the irrigation stream is pulsed and water table is allowed to fluctuate, the system should have the capacity to build the water table to the desired depth within twelve hours over the entire field. Briefer periods are desirable.
3. If erosion is a problem, recommend methods or practices to control erosion.
4. Estimate amount of water loss in the delivery system.
5. Estimate tailwater loss and consider methods to reduce loss if it exceeds 10 percent of the total water pumped to the field or if it occurs for more than two hours.
6. Analyze drainage problems. It is desirable to remove excess surface water within 24 hours or less on a two to five year frequency rainfall. The water table should drop to a 12-inch depth from the top of the bed within 24 to 48 hours after surface water removal. Consider the type of crop being grown and any applicable regulatory requirements, when proposing drainage solutions.
7. Run the DRAINMOD computer model when the furrow spacing exceeds the Florida Drainage Guide recommendations and the water table variation in the field at the beginning of the irrigation cycle exceeds 0.5 feet. DRAINMOD can be downloaded from North Carolina State University at the following web address: http://www.bae.ncsu.edu/soil_water/drainmod/index.html. Check the model's output of predicted water table response. Compare this data with how well the system responded to irrigation and observed drainage.

8. Use FIRI to rate the irrigation system. (See Exhibit 1.)

$$\text{FIRI} = E \times W_c \times C_e \times LR \times Md \times S \times I \times M \times D \times Sc$$

The analysis of the field data for a *detailed* field evaluation is essentially the same as for the *general* field evaluation; however, the use of more accurate data and possibly more data should result in a more precise analysis.

2.6.4 Typical Problems and Recommendations for Subirrigation Systems

The analysis should indicate recommendations for improved management and/or system modifications. A review of the various management and system factors should be a starting point in making recommendations to the landowner. Additional items to review and address for a *general* field evaluation are as follows.

1. Furrows should be spaced to allow no more than 0.5 foot variation in water table depth from furrow to mid-point, during periods of peak consumptive use, after the water table has stabilized. Variations in water table may suggest the need for irrigation land leveling, closer spacing on irrigation furrows, and/or closer spacing of water table control structures. Larger irrigation streams are required when excessive time is required to raise the water table in the entire irrigation system to the desired depth.
2. Normally the water table should be raised to the predetermined desirable level during each 24-hour period. Irrigation during the night is more efficient.
3. Increased depths to the water table decreases the amount of water lost from evaporation from the soil surface. Though this increases irrigation efficiency, it is essential that the water table is within the zone that will supply adequate moisture to the root zone (through upward flux).
4. Water erosion can be controlled by structures at the ends of laterals, reducing the irrigation stream, structures in open ditches, and/or changing system layout to reduce slope in the direction of irrigation.
5. Wind erosion may be reduced by maintaining a water table depth during fallow periods at a level that will provide moisture to the ground surface.
6. Prevent delivery system losses by using underground pipelines or an underground conduit system.
7. Reduce tailwater losses by one or more of the following.
 - a. Installing water table control structures in outlet drainage ditches at 0.5 foot (or less) elevation intervals to maintain desired water table depths.
 - b. Allowing the water table to fluctuate within an allowable range. Stop irrigation when water is raised to a desired depth. Start irrigation when water table drops to a predetermined depth. This may be automated with electric motors and switches on water control structures or on floats in observation wells.
 - c. Installing a tailwater recovery system.
 - d. Regulating irrigation streams to a continuous flow which minimizes tailwater losses. Water will normally recede up to the furrows during peak use period of the day (from noon to early afternoon, normally).

8. Poor drainage suggests the enlargement of drainage ditches, increased capacity of structures, increased depth of irrigation laterals, and/or installation of subsurface drains. An underground conduit sub-irrigation system should normally be recommended when subsurface drains are required.
9. Cased observation wells that are properly located should always be recommended to allow the irrigator to observe the position of the water table at any time.

The recommendations for a *detailed* field evaluation should be the same as those suggested by the *general* field evaluation. However, the use of more information and background data is available to make economic comparisons and to allow for more accurate design and/or system modifications.

Exhibit 1. Farm Irrigation Rating Index Worksheet



Farm Irrigation Rating Index - Florida (FIRI - FL) Version 1.0

Cooperation:		Farm Name:	
Location:		Field ID:	
Conservation District:		Field Office:	
Water Management District:		County:	
Irrigated Crop:		Irrigated Area, acres:	
Net Irrigation Requirement, inches:			

Category:	Present Condition	Planned Condition
Irrigation System Type		

Management Factors

Category:	Action	Rating	Action	Rating
Improved Water Management				
Improved Soil Moisture Monitoring and Irrigation Scheduling				
Irrigation Skills and Action				
Water Service Factor				
Water Delivery				
Improved Soil Condition Index				

System Factors

Category:	Action	Rating	Action	Rating
Improved Distribution System				
Improved Conveyance System	Material	Length (ft)	Material	Length (ft)
Improved Land Leveling				
Adding Tailwater Recovery With and Without Irrigation Storage Reservoirs				
Climatic Factor				
Wind Factor				
Sprinkler Factor				
Emitter Clogging Factor				
Drip-Micro Design Factor				

FIRI Rating: Present Condition = _____ Planned Condition = _____

Change in FIRI Rating	
Water Conserved per acre	
Water Conserved (gallons)	
Water Conserved @acre-feet	
Water Conserved @acre-inch	
Water Conserved	

Comments:

Prepared by: _____ Date: _____

Checked by: _____ Date: _____

Chapter 3— Evaluation of Urban Irrigation Systems

The evaluation of urban systems is based on a test of the pressure throughout the system and a measurement of the uniformity with which the water is distributed over the field surface.

3.1 Common System Components in Urban Irrigation

Most residential irrigation systems consist of the following components: a pressurized water supply, poly-vinyl chloride (PVC) pipe or polyethylene (PE) pipe, a controller and control valves, a backflow prevention assembly, sprinklers and a rain shut-off device. In addition, the use of low volume irrigation components such as drip tubing and low-flow emitters is highly recommended for shrub areas.

The controller is a timer, either electronic or mechanical (see Figure 5), connected to a series of valves that turn the system on and off on specified intervals. Each area that is watered by a control valve is called a zone. Electronic controllers are often preferred because they can offer a variety of options such as allowing different operating schedules for each zone.

The backflow prevention assembly allows one way flow between the meter and the control valves. This prevents water from backing up into the main line and contaminating the metered water supply or a residential well (see Figure 3). Control valves allow flow to each individual zone and are operated by the controller (see Figure 4).

Sprinklers are divided into two basic types: rotors and spray heads. Spray heads are designed to apply water at a relatively high rate (approx. 1.5 in./hr.) to the immediate surrounding area (see Figure 5). Spray heads can be used to irrigate areas with radii from 8 to 17 feet, although they usually irrigate a radius of 10 to 15 feet. Because of their high application rate, spray heads are typically operated for 15-20 minutes per irrigation cycle.

Rotors are divided into two general categories: gear driven and impact. They have a lower application rate than spray heads (approx. 0.3 to 0.7 in./hr.). Impact rotors are usually the least expensive. They operate by using water pressure to cause a spring loaded arm to pivot, which turns the rotor (see Figure 6). Impact rotors are easy to adjust, but can easily stick in one position if sand or debris gets into the operating mechanism. Some common impact rotors are not available in a wide range of flow rates and do not have some useful features such as interchangeable nozzles.

Gear driven rotors are generally preferred over impact rotors to achieve a uniform application of water. The primary advantage of a gear driven rotor is that the operating mechanism is encased, protecting it from dirt and debris. Gear driven rotors are available in a wide range of flow rates and can be adjusted to rotate over a full or fraction of a circle (see Figure 7). High quality rotors that have interchangeable nozzles are available from many manufacturers. Interchangeable nozzles offer the most flexibility when determining irrigation duration.

Microirrigation such as drip or micro spray irrigation should be used for shrubs or trees. Drip irrigation delivers water directly to the root system with minimal loss to evaporation. Although this manual will not address testing drip systems for efficiency, drip systems should be inspected to insure proper function and to identify problems such as leaks. Historically, drip systems were plagued by problems of clogging from suspended solids in the water, polyethylene tubing that was prone to cracking, and valves that were unreliable at low flow rates. New emitters are

virtually clog proof and more dependable when used in conjunction with high quality filters and valves designed for low volume irrigation (see Figure 8) (Sunset, 1988). If an irrigation system has a low flow irrigation zone, check to see if a filter has been properly installed. Most manufacturers will recommend a 200 mesh screen for drip systems and 80 mesh screen for micro spray emitters (Smajstrla, et al., 1994). The mesh number of a screen is the number of openings per square inch through which water can flow. Using drip irrigation, runoff can be eliminated and water loss due to evaporation can be greatly reduced for a water savings of up to 70 percent (Sunset, 1988).

One of the most important components in an efficient irrigation system is a device to turn the system off when sufficient rainfall occurs. Two such devices are rain shut-off devices and soil moisture sensors. Each type has benefits and drawbacks. Soil moisture sensors are usually more expensive than rain shut-off devices. They also do not meet current Florida Statute requirements that all new irrigation systems have a rain shut-off device installed. Soil moisture sensors do not actually measure water content in the soil, but they measure a parameter, such as electrical conductivity, that is associated with soil moisture content. The main problem with soil moisture sensors is that they are difficult to calibrate and may have to be adjusted after fertilization or pesticide application.

Rain shut-off devices are small devices, usually mounted on the eave of a house, connected to the irrigation controller (see Figure 10). They are required by law on all new irrigation systems. After sufficient rainfall, usually 0.5 inches, the irrigation system skips a scheduled watering cycle. When enough water evaporates, the irrigation system timer begins to control the system again. Some rain shut-off devices may require periodic cleaning to remove dirt and debris from the operating mechanism. One drawback is that rain shut-off devices operate on the assumption that evaporation occurs at the same rate as evapotranspiration (ET). ET is evaporation that occurs through plant stomata and from moist soil combined with water loss due to cellular respiration. Although this assumption is not quite accurate, it is adequate for non-commercial applications.

Figure 5 – Hybrid Controller

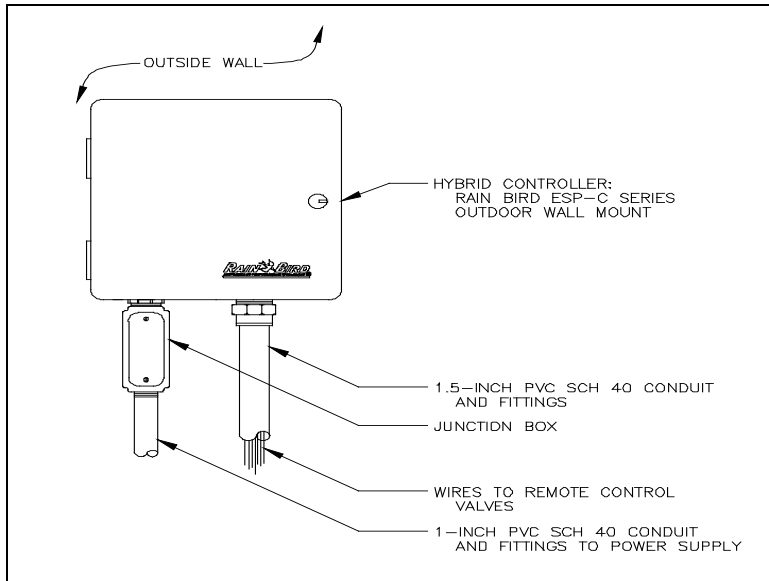

Figure 6 – Pressure Vacuum Breaker

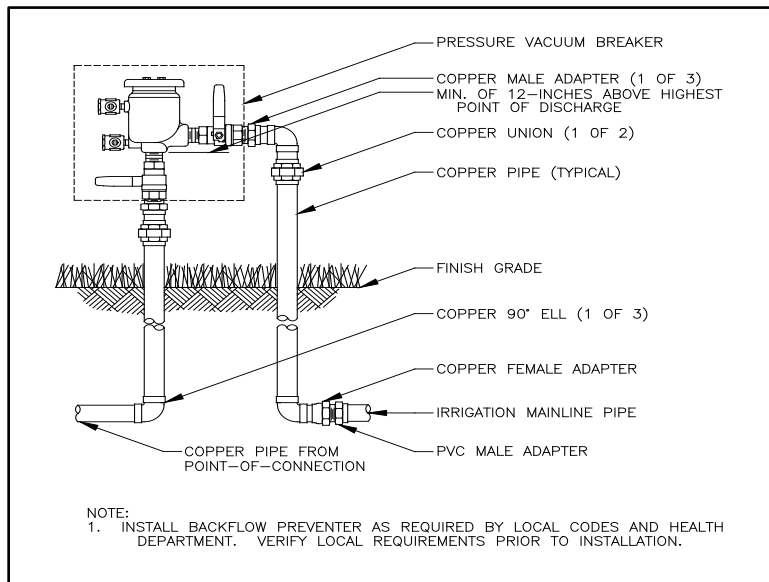

Figure 7 – Remote Control Valve

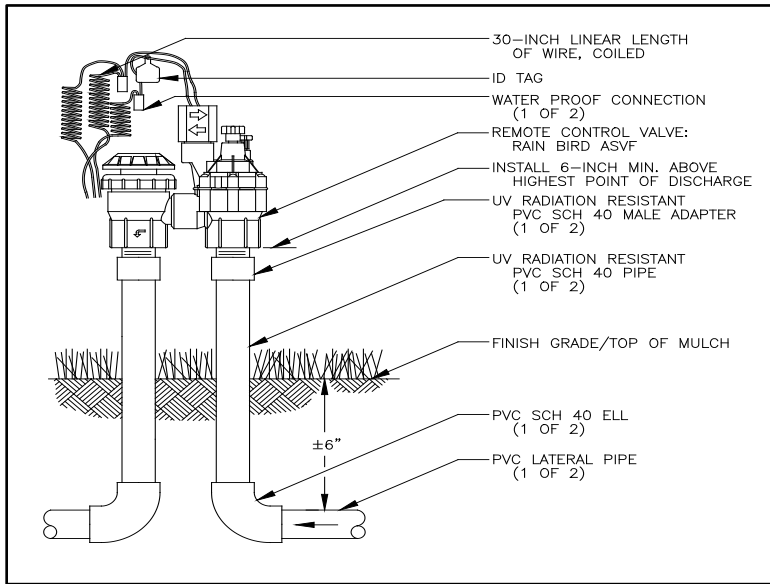

Figure 8 – Pop-up Spray Sprinkler

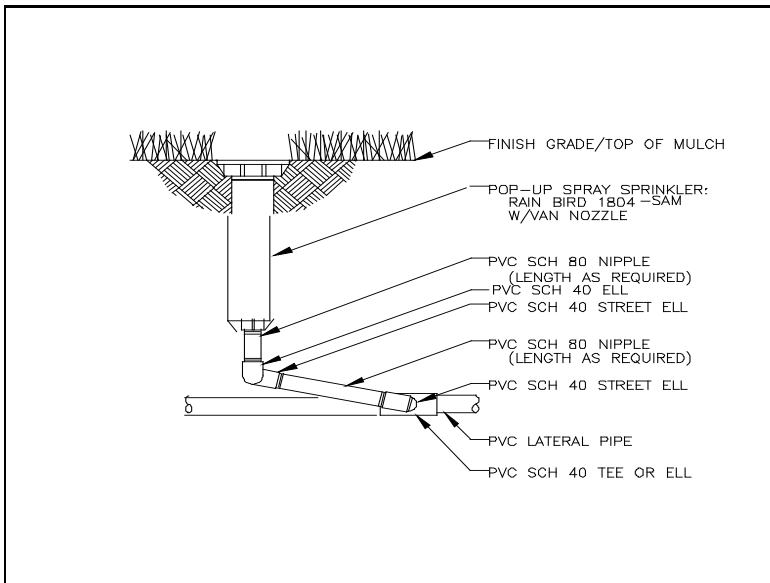

Figure 9 – Impact Sprinkler

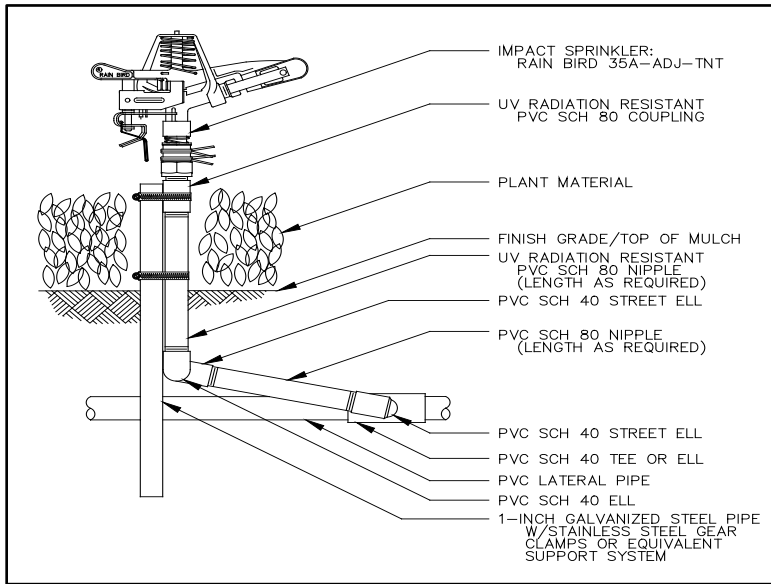

Figure 10 – Xeri-Tube_PC

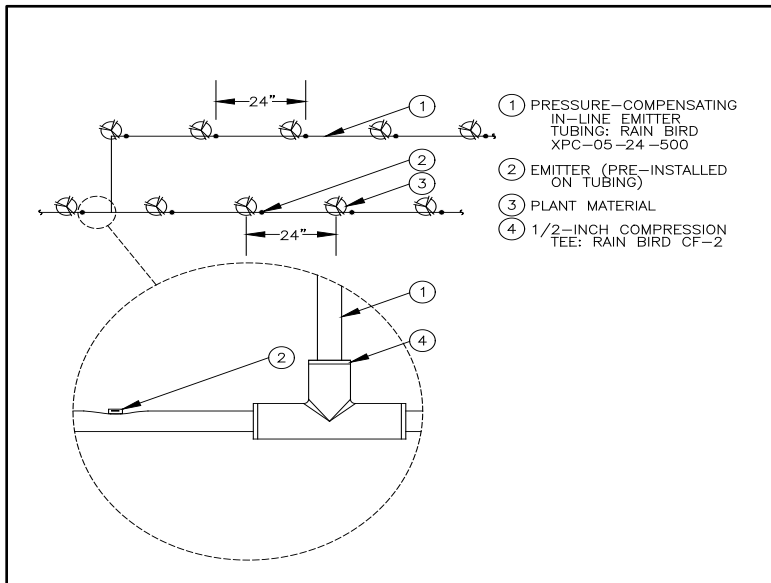
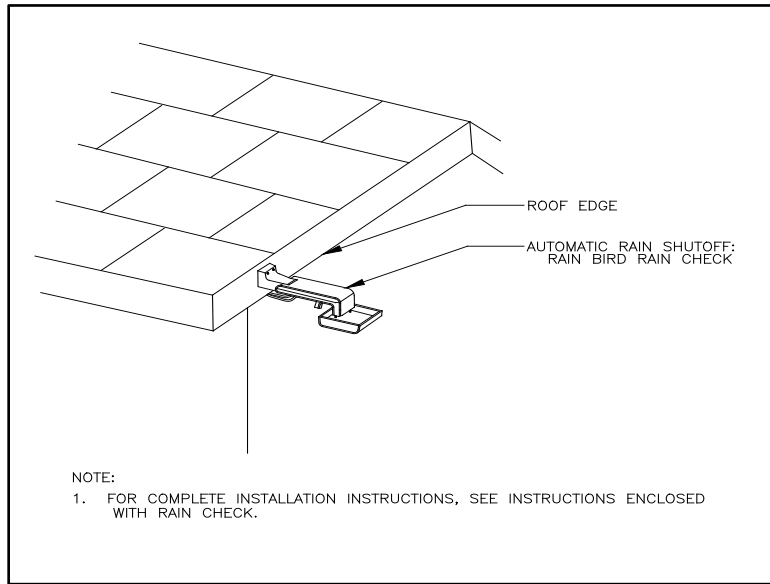
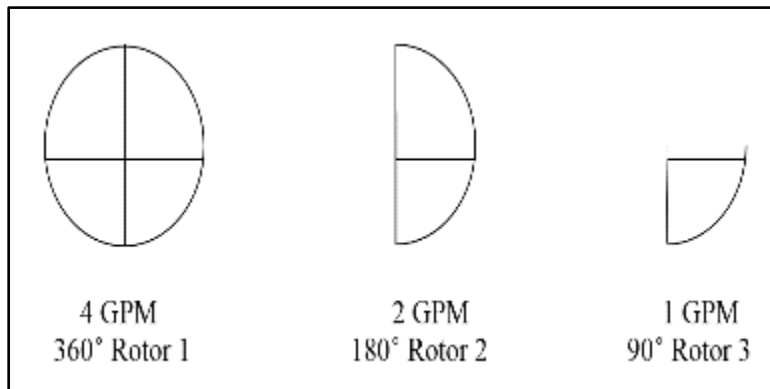

Figure 11 – Automatic Rain Shutoff



3.1.1 Matched Rates

A system with matched precipitation rates will have a uniform application rate throughout the system. When a rotor rotates over $\frac{1}{4}$ of a circle it should apply water at $\frac{1}{4}$ the rate of a rotor covering a full circle on the same zone. The rotor covering 90° of a circle will irrigate its area four times in the time required for a 360° rotor to cover a full circle. Spray heads are automatically matched when similar types are used.



Example

Rotor 1 is irrigating 4 times the area of Rotor 3, and therefore should discharge 4 times the amount of water.

3.1.2 Sprinkler Spacing

Sprinkler spacing is critical for achieving a uniform application of water. Head to head sprinkler spacing should be at distance equal to 50% of the sprinkler's diameter to ensure even distribution

of water to eliminate dry areas in the lawn. This is not difficult to achieve on large rectangular fields, but requires careful planning on oddly shaped residential lots. The radius of the spray pattern is adjustable on most rotors and spray heads by turning an adjusting screw on top of the sprinkler. Adjustments should be made to achieve head to head coverage if possible, without spraying on to non-irrigated areas, such as streets or driveways. However, the full radius of the sprinkler should not be reduced by more than 25%. Significantly reducing the sprinkler radius will excessively degrade the spray pattern.

3.1.3 Mixed Zones

A mixed zone is one which has different types of sprinklers, such as rotors and spray heads. As stated earlier, uniform application requires matched rates. Spray heads usually apply water at a rate of 1.5 in./hr.. Rotors used in residential systems will usually apply water at 0.3 to 0.7 in/hr. If an irrigation system is applying water to turf between the sidewalk and street with spray heads and watering the front lawn with rotors at the same time, the spray heads will run 2 to 5 times longer than necessary so that the front lawn will receive adequate irrigation. Therefore spray heads and rotors should be on different zones.

3.1.4 Soil Texture Determination

The maximum application rate that can be applied to a zone is determined by how fast water will infiltrate the soil in that zone. If water is applied faster than the infiltration rate, then runoff will occur. Soil texture in a particular area can be approximated using NRCS Soil Surveys. However, in urban areas where soil has been disturbed, the Soil Survey may not be accurate. The following flow chart was developed for the Hydric Soils of Florida Handbook (Carlisle, 1995) and may be used for determining the texture of soil at an evaluation site. For additional information on soil texture determination, consult from the local NRCS field office.

Field Determination of Soil Texture

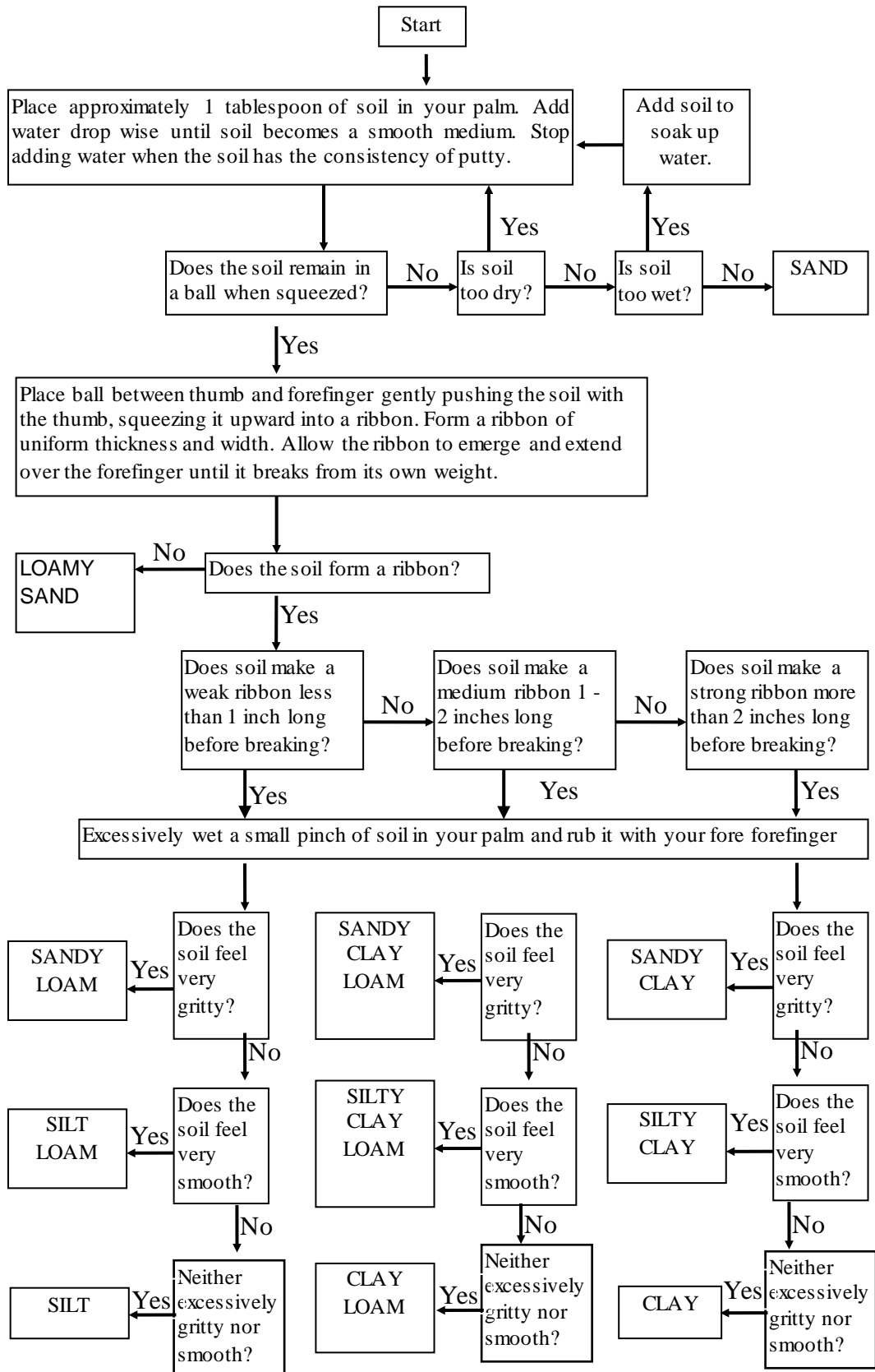

Only a catch can test is conducted (no pressure and flow)

Use the following formula to calculate the average application rate from the DU test:

$$\text{Average Application Rate} = \frac{\text{Volume}}{D^2 * \text{time}} \times 4.66$$

Where *Average application rate* = Inches per hour [in./hr.]
Volume = Average volume of water collected per catch [ml]
D = Diameter of the top of the catch can [in]
time = Time of zone operation [min]

3.1.5. Determine Distribution Uniformity

$$DU = \frac{\text{Low quarter average}}{\text{Total average}} \times 100$$

Where *DU* = Distribution uniformity in percent
Low quarter average = Average volume in the 25% of cans that received the least water [ml]
Total average = Average volume of all cans [ml]

If no DU test is conducted, an estimate of 50% to 70% should be assumed based on spacing and system layout.

3.1.6 Materials List

The following materials will be required to conduct evaluations.

3.1.7 Visual Inspection

1. Pad and clipboard
2. Pen or pencil

3.1.8 Pressure and Flow Test

1. Pad and clipboard
2. Pen or pencil
3. Pitot tube and pressure gauge that reads up to 80 psi
4. Graduated cylinders (25 ml, 50 ml, 100 ml, and 1000 ml)
5. 100 foot plastic measuring tape
6. Stopwatch
7. Bucket or a one gallon container to collect water from a sprinkler nozzle
8. Survey wheel
9. Pressure gauge capable of measuring pressure from spray heads

3.1.9 Catch Can Test

1. Pad and clipboard
2. Pen or pencil

3. Survey wheel
4. Cans or catchment devices to collect water
5. Method of securing cans in place (i.e. rubber bands and 18 inch wooden dowels)
6. Survey flags
7. Timer or stopwatch
8. Graduated cylinder

3.1.10 Other Miscellaneous Equipment

1. Tool kit with small screw drivers, pliers, and allen wrenches
2. Calculator
3. Manufacturer's catalogs for common system components

3.2 Visual Inspection

The visual inspection is a simple check list that requires a minimum investment of time. It is designed to be conducted in 15-30 minutes to make sure that the system appears to have been installed properly and complies with local regulations.

Are plant beds on separate zones from turf?

One of the most common over-watering problems encountered in residential systems is caused by shrub beds and turf being irrigated in the same zone. Most shrubs require less frequent watering than turf and some common landscape shrubs require no supplemental watering once they are established. When shrub beds are watered with turf, the beds are almost always over-watered.

Are rotors and spray heads on separate zones?

Spray heads apply water two to three times faster than rotors. Spray heads and rotors should be on separate zones for uniform application.

Are spray heads turned off in areas with mature, natural shrubs?

Plant guides provided by the University of Florida Institute for Food and Agricultural Sciences (IFAS) define "natural" as surviving only on rainfall. Zones landscaped with natural shrubs and ground covers do not need to be operated once plants are established. Consult an IFAS Plant Guide for a complete list of natural trees, palms, shrubs, ground covers and vines.

Does the current irrigation schedule water excessively?

Without conducting either a pressure and flow test, or a catch can test, it is impossible to determine the application rate and therefore the correct operating time for an irrigation system. In general however, 45 minutes and 15 minutes is adequate for most rotor zones and spray zones respectively.

Is a rain shut-off device installed and is it functioning properly?

Make sure the property manager has an automatic rain shut-off device properly installed. It should be installed so that rainfall can reach the device easily and where it will not be watered by the

sprinkler system. This allows the system to function automatically if the property manager forgets to check the soil wetness or is away from home.

Is the system operated during designated times?

Inspect the controller to make sure the operating schedule complies with local watering restrictions.

Is irrigation sprinkler spacing correct?

Proper spacing is necessary for uniform coverage. Inspect the system to see if the spray pattern from one sprinkler overlaps at least 80% of the radius (40 % diameter) of existing systems or 100% of the radius (50% diameter) in new systems to the adjacent sprinklers.

Are flow rates from sprinklers matched?

The flow rate from rotors covering $\frac{1}{4}$ circles should be $\frac{1}{4}$ of the flow rate from rotors covering a full circle. Without conducting flow rate measurements this is determined by visual inspection. Rotors frequently have a number associated with their flow rate either stamped on top of the sprinkler or on the nozzle. Compare this number with manufacturer's catalogs to make sure that rotors irrigating $\frac{1}{4}$ circles and $\frac{1}{2}$ circles are delivering water at $\frac{1}{4}$ and $\frac{1}{2}$ the rate of rotors watering full circles.

Is the irrigation stream from rotors free from obstacles?

Keeping turf trimmed low around rotors is the easiest way to improve system uniformity. Some rotors only rise 4 inches. If turf is allowed to grow up around rotors a substantial portion of the applied water is blocked and not available to the rest of the zone.

Is the spray pattern from spray heads free from obstacles?

If spray heads are used for shrub and ground cover irrigation, leaves and branches should be removed from around spray nozzles. Shrub interference around the spray stream can block most of the applied water, preventing water from reaching root zones.

Are risers used to place spray heads above or below shrub interference?

When spray heads are installed for shrub irrigation, they are designed for the shrub height at the time of installation. As shrubs grow, spray heads will need to be raised or lowered.

Is all water applied within the landscape area?

Water being applied to driveways or sidewalks can run off into the street, and into storm water drains. To reduce this waste, adjust sprinklers so that watering onto concrete areas is minimized.

Are sprinklers undamaged?

Inspect sprinklers for damage from lawn mowers, cars, etc.

Are sprinklers unclogged?

Inspect spray heads and rotors for clogging. If the flow from one spray head or rotor appears low and system pressure appears to be adequate throughout the zone and no leaks are found, the nozzle is probably clogged. Spray nozzles easily unscrew and can be washed out. If a gear driven rotor becomes clogged the nozzle must be removed and thoroughly cleaned.

Are sprinkler heads protected from hazards?

One of the most common irrigation system maintenance problems is broken sprinklers that have either been hit by a lawn mower or run over by a car. Sprinklers subjected to these possible hazards, especially along the driveway, should be protected with flex joints or concrete donuts.

Are rotors and spray heads in upright position?

Sprinklers must be perpendicular to the ground to more uniformly apply water across the zone.

Do all rotors have like characteristics?

There is no single best rotor. Most have a variety of features to distinguish themselves from their competition, and each has benefits and drawbacks. Each brand does have performance characteristics that define how it applies water over distance. For uniform applications, rotors with similar characteristics should be used throughout the zone.

Landscape (Optional)

For detailed information on drought tolerant plant material, consult IFAS personnel and literature.

Do turf and plants appear healthy?

Inspect leaves for fungus, or signs of over watering. Look for areas in the turf where water coverage may not be adequate.

Are beds planted with natural vegetation?

A good way to reduce the amount of required supplemental irrigation is through the use of natural vegetation. IFAS plant guides define “natural” as surviving only on rainfall. Zones landscaped with natural shrubs and ground covers do not need to be operated once plants are established. Turning shrub zones off completely can save thousands of gallons of water per year.

Has the property manager landscaped with drought tolerant turf?

St. Augustine turf has low drought tolerance. If the property manager is re-landscaping in the future or is planning to sod their yard, recommend a drought-tolerant turf such as Bahia. If the appearance of St. Augustine is desired, consider recommending FX-10 which is similar to St. Augustine, but develops a more extensive root system and is very drought tolerant.

Is mulch being used appropriately in beds?

At least 4 inches of mulch should be applied to shrub beds to keep moisture in the ground. This minimizes water lost to evaporation. When mulch is applied correctly, supplemental watering should be reduced. Too much water applied to the roots can result in fungus problems.

Are low volume emitters being used for bed irrigation?

Spray heads are most commonly used to irrigate shrub and ground cover beds. Spray heads apply water to the surface of leaves and to the surface of mulch where it is not useful to the vegetation. By using low flow emitters on the ground surface, below the mulch, water can be applied directly to the root zone. This reduces the required supplemental irrigation by as much as 70%.

Irrigation System Visual Inspection

Name _____

Date ____ / ____ / ____.

Address _____

Phone (____) ____ - ____.

Layout

YES NO

- Are turf and shrub beds on separate irrigation zones?.....
- Are rotors and spray heads on separate irrigation zones?.....
- Are turf or plant areas that require irrigation receiving it?.....

Appropriate timer settings

- 45-60 minutes or less for rotor zones?
- 15-20 minutes or less for spray zones?.....

Rain Shut-off Device

- Is a properly installed rain shut-off device present?.....

Designated Operating Times

- Is the irrigation system operating during designated times?.....
- Are sprinklers covering at least 80% of the distance to the.....
next sprinkler?

Matched Sprinklers

- Are all flow rates matched to the area covered?.....

Interference

- Are spray patterns free from interference caused by vegetation.....
or other objects?

Application Outside Landscape

- Is all the water applied within the landscape area (does not
extend non-irrigate areas (driveways, sidewalks, etc.)?

Maintenance

YES NO

- Are sprinklers undamaged?.....
- Are sprinklers unclogged?.....
- Are sprinklers protected from hazards?.....
- Are there leaks in pipes?.....
- Are rotors and spray heads in an upright position?.....
- Are all rotors and spray heads from the same manufacturer?.....

Turf and Plants (Optional)

- Do turf and plants appear healthy?.....
- Are beds planted with natural vegetation?.....
- Has the property manager landscaped with drought tolerant turf?.....
- Is mulch being used appropriately in beds?.....
- Are low volume emitters being used for bed irrigation?.....

3.3 Pressure and Flow Inspection

The pressure and flow inspection is a continuation from the previous questionnaire and involves a detailed inspection to evaluate the layout and operating condition of the irrigation system. The following additional questions are addressed in the pressure and flow test:

Does the current irrigation schedule water excessively?

The maximum water that should be applied during any one watering is 0.5 inch throughout most of the state (0.25 inch is used in parts of south Florida where the soil depth is very shallow). This represents the amount of water that can be held in one foot of sandy soil. One foot is assumed to be the maximum root depth that most types of turf achieve. Watering over 0.5 inch during one irrigation cycle will force water down below the root zone and provide no benefit to the landscape.

The operating time required to achieve 0.5 or 0.25 inch of precipitation is addressed in the application rates portion of the irrigation water management report.

Is there adequate system pressure in each zone?

System pressure on rotor zones is determined by turning the system on and holding a pitot tube attached to a pressure gauge in the stream of the rotor, about 1/8 of an inch from the nozzle.

Although some manufacturers claim their rotors function correctly at 20 psi, in general, the minimum acceptable pressure is 25 psi at the farthest head in a zone.

System pressure on spray head zones can be determined by installing a pressure gauge in line between the pop-up riser and the nozzle of a spray head sprinkler. There is no tool commercially available to make this measurement, but some NRCS field offices have constructed their own. The pressure should be checked at the first and last spray head in a zone. The farthest sprinkler should have a minimum operating pressure of 15 psi and all heads within the zone should operate in a range of 15-30 psi.

Visually inspect sprinklers for proper operating pressure. Inspect pop-up spray heads and gear driven rotors for leaks between the spray body and the pop-up riser. Inspect the spray pattern from gear driven rotors. Does the pattern appear to be a uniform application of water or is water applied in stream producing a donut shaped irrigation pattern. Finally, inspect impact rotors for proper functioning. Low water pressure will usually cause impact rotors to stick in one position.

Are flow rates from sprinklers matched?

The flow rate from rotors covering 1/4 circles should be one fourth the flow rate of rotors covering a full circle. Flow rate should be measured on each sprinkler by placing a bucket or a one gallon milk container in front of the rotor stream for a timed duration using a stop watch. Measure the water collected using a 1000 ml graduated cylinder. Determine the flow rate from the following equation:

$$Flow\ rate = \frac{Volume}{Time} \times 0.01585$$

Where *Flow rate* = Gallons per minute [gpm]
Volume = Volume collected [ml]
Time = Time that water was collected [sec]

If recommending changes to the rotors in the system, new flow rates can be predicted from system pressure and manufacturers catalogs. (Toro S-600 rotors for example are stamped on top with their design flow rate of either 1.3, 2.5, or 5.0 gpm at approximately 30 psi. Toro S-700 rotors have their design flow rate stamped directly on the nozzle; 1.5 gpm at 40 psi, 2.0 gpm at 45 psi, 3.0 gpm at 40 psi, 4.5 gpm at 55 psi, or 6.0 gpm at 45 psi. Hunter G-Type rotors are numbered 1-12. A number 1 nozzle delivers 0.7 gpm at 50 psi and a number 12 delivers 12.2 gpm at 50 psi. Typical matched rate applications for Hunter rotors would include No. 2, No. 5, and No. 8 nozzles for 90°, 180°, and 360° applications respectively.) **Consult manufacturers catalogs for appropriate flow rates over a range of pressures.**

Flow rates from spray heads are automatically matched when similar spray heads are used. However, it may still be important to determine the flow rate from individual spray heads to determine water use on spray head zones. The flow rate from spray heads can be determined by either measuring the pressure at each sprinkler and looking up flow rates from manufacturer's catalogs or by directly measuring the flow rate. Direct measurement can be made with a stopwatch and some type of container such as a bucket. Allow the spray head to fill the bucket for a timed interval. Measure the water collected and use the equation above to calculate the flow rate. This method is usually only practical when measuring the flow rate from spray nozzles irrigating half of a circle or less. To determine flow rates from 270° or 360° spray nozzles, multiply the flow rate calculated for 90° spray nozzles by 3 and 4 respectively.

Irrigation System Pressure and Flow Inspection

- | | | |
|--|--------------------------|--------------------------|
| | YES | NO |
| Does the current irrigation schedule water excessively?..... | <input type="checkbox"/> | <input type="checkbox"/> |
| Is there adequate system pressure in each zone?..... | <input type="checkbox"/> | <input type="checkbox"/> |
| Are flow rates from sprinklers matched?..... | <input type="checkbox"/> | <input type="checkbox"/> |

Pressure and flow worksheet:

$$\text{Adjusted flow rate} = \frac{\text{Flow rate}}{\text{Fraction of circle watered}}$$

The flow rate is derived by the following equation:

$$\text{Flow rate} = \frac{\text{Volume, ml}}{\text{time, sec}} \times 0.01585$$

Zone # Rotor #	Pressure (psi)	Volume (ml)	Time (sec)	Flow rate (gpm)	Fraction of circle watered	Adjusted flow rate

Zone # Rotor #	Pressure (psi)	Volume (ml)	Time (sec)	Flow rate (gpm)	Fraction of circle watered	Adjusted flow rate

3.4 Catch Can Distribution Uniformity Test

In addition to the pressure and flow inspection, some systems may benefit from a level three evaluation, or catch can test. The level three evaluation requires more time, but provides more precise information about the sprinkler system. A distribution uniformity (DU) test shows an

evaluator the location of dry spots as well as the application rate of turf zones. This provides information that allows the evaluator to recommend how long to operate the system for improved efficiency. If a system is in a state of disrepair, then a catch can test is rarely helpful. If however, an irrigation system is well maintained and properly operated, then a DU test will allow the property manager to fine tune his or her watering practices. (For example, if a DU test shows that the operating time of a zone can be reduced by 5 minutes, this could save an additional 6000 gallons over the course of 1 year.)

The report generated by the level three test is designed to provide the property manager with precise information on a zone-by-zone basis with specific recommendations for each zone.

The catch can test requires placement of catch cans (usually a type of cup) throughout a zone. The zone is then turned on long enough for a measurable quantity of water to fall into the cans. Usually an operating time of 7-10 minutes is long enough for spray head zones. Rotor zones typically require 20-40 minutes.

3.4.1 Selecting Catch Containers

Many containers can be used for the DU test, however the following features should be considered (Schwankl, *et al.*, 1992). In accordance with ASABE standard S398.1, "All collectors used for any one test shall be identical. They shall be such that the water does not splash in or out. The position of all collectors shall be maintained such that the entrance portion is level."

- The top should be at least 2 inches in diameter, or 3 square inches in area.
- Containers should flare toward the top to allow easy stacking.
- Plastic containers are preferred to glass or metal because they do not break or rust.
- Containers should not tip over easily.

3.4.2 Selecting a Zone or Zones

For a residential system, the zone normally selected is the front yard, since it is usually the most visually important to the property manager and represents a large turf area within the system. If other turf zones are designed with the same brands of sprinklers and have a similar layout, then assume other zones will operate with similar efficiency and uniformity. For irrigation systems that have eight zones or less only one zone is required for testing. On large systems with more than eight zones, break zones up into groups of similar layout. Test at least one zone from within each group.

3.4.3 Placing Catch Cans

Catch cans should be arranged in a uniform grid using at least 16-24 cans (Smajstrla, *et al.*, 1990). Using more cans will improve accuracy; however, the test can become cumbersome. In general, try to use 40-50 cans to provide a strong indication of the uniformity of the system.

The grid layout should be completely within a zone. If the test area is watered by more than one zone, then all zones watering the area will need to be operated. For example, if the front lawn is watered primarily by zone 1, but is also irrigated by zones 2 and 3, then only operating zone 1 will

show a lower application rate on the front lawn than is actually being achieved. To place close to 50 cans the grid layout will usually be 10X5, 8X6, or 7X7, depending on the shape of the zone.

Using plastic 100 foot tape measure or a three foot surveyor's wheel, measure the length and width of a zone. The length to width ratio will decide which configuration of catch cans to use.

Table 6 - Proposed catch can layout for varying length to width ratios.

L/W	Grid Layout
>1.75	10 x 5
1.25-1.75	8 x 6
<1.25	7 x 7

For a 10 x 5 layout, divide the length of the zone by 10. This will be the number of feet between each can in the length direction. Divide the length of the zone by 20. This will be the distance from the edge of the zone that the spacing of the cans begin. Now divide the width by 5 to determine the number of feet between each can in the width direction. Divide the width by 10 to calculate how far from the edge to begin placing cans.

For an 8 x 6 grid of cans, divide the length by 8. This will be the number of feet between each can in the length direction. Divide the length by 16 to determine the distance from the edge that the spacing of the cans begin. Now divide the width by 6 to calculate the distance between each can in the width direction. Finally divide the width by 12 to see how far in from the edge to place the first can.

For a 7 x 7 grid divide both the length and width by 7 and then by 14, following the procedures outlined above. This following example illustrates the principles above.

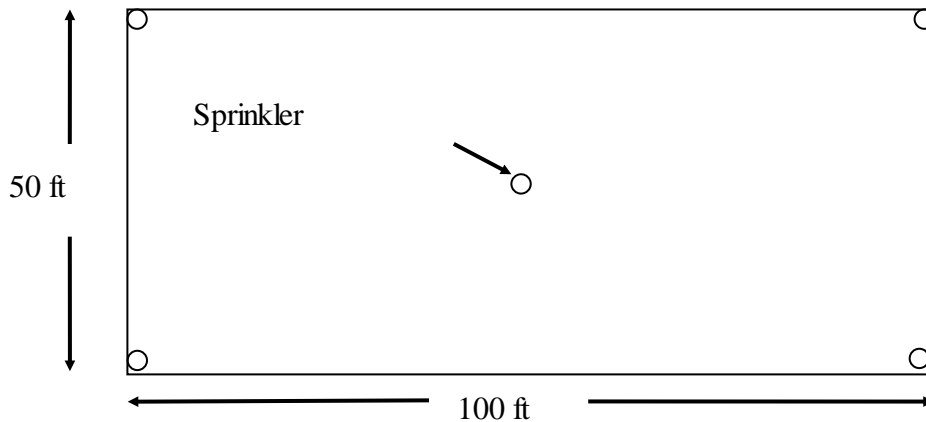

Exhibit 1 - Sprinkler location for front lawn

Given: L=100 feet, W= 50 feet

Calculate: Grid spacing and catch can locations

$L/W = 2$, A 10 x 5 grid of catch cans should be used.
 $L/10 = 10$, Spacing between each can will be 10 feet in the direction of length.
 $L/20 = 5$, Spacing should begin 5 feet in from the sides.
 $W/5 = 10$, Spacing between cans should be 10 feet in the direction of width.
 $W/10 = 5$, Begin grid 5 feet from top and bottom edge.

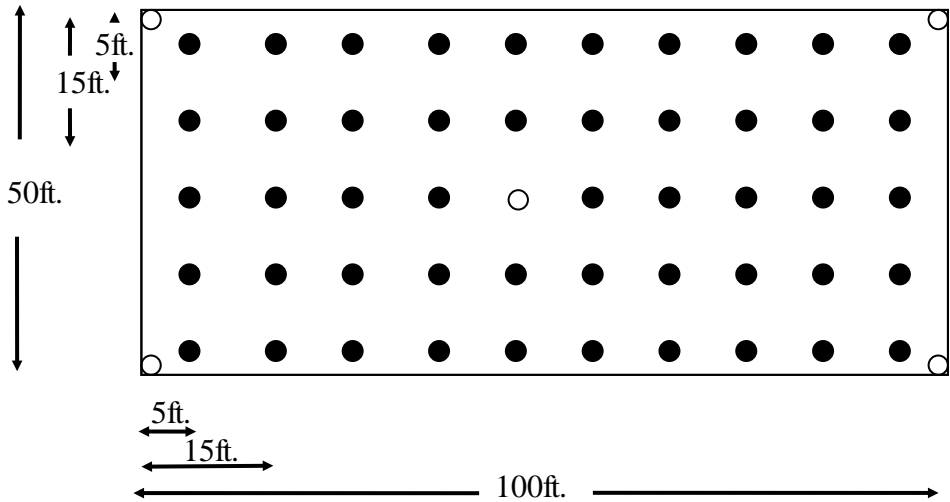

Exhibit 2 - Catch can placement in front lawn

Notice that the center catch can has not been used. When the location of a can is close to a sprinkler, tree or other obstacle, remove that can. By planning for 48, 49, or 50 catch cans, enough information will be obtained to accurately describe the system, even if a few cans have to be removed.

3.4.4 Selecting Subzones

For large zones, such as those on golf courses or some commercial properties, testing an entire zone may not be practical. In this case choose a subsection of the zone (Smajstrla, *et al.*, 1990) as shown in Figure 10. Subsections should be completely within one zone and should be representative of the zone as a whole. There is no set rule for determining the grid layout for subzones. You will have to use your own judgment to place nearly 50 cans in a series of grids throughout the zone.

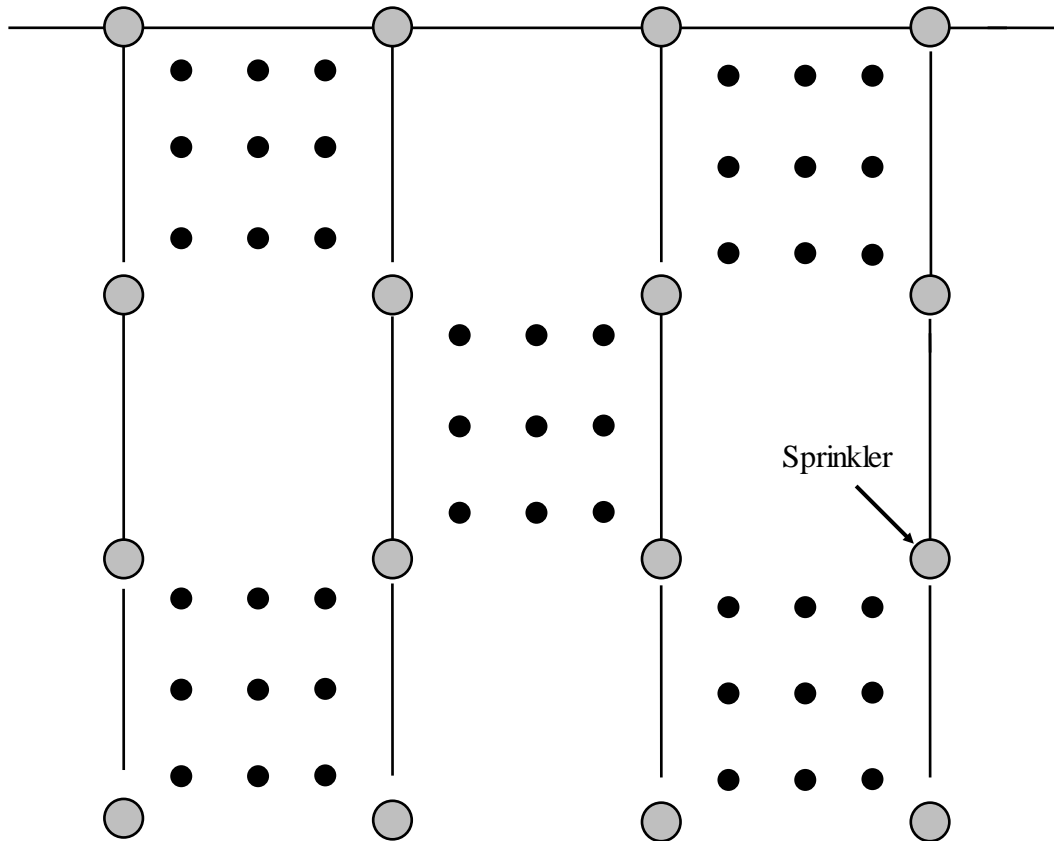

Exhibit 3 - Large turf zone requiring the use of sub zones.

3.4.5 Test Duration

The duration of the test will depend on the application rate of the zone being tested. The zone being tested should be operated long enough for each can to catch a measurable amount of water; at least 5 ml. The duration will usually be 20-40 minutes for rotor zones and 7-10 minutes for spray head zones. Visually check cans during the test to see when a measurable amount of water has been collected.

3.4.6 Measuring and Recording Data

Once the test is over, turn the system off and measure the water collected in each of the cans using a graduated cylinder. Record this value on a data sheet in the grid pattern in which the cans were measured. This will point out dry and wet areas, and aid in the report writing process. For example, the data from the catch cans above should be recorded on a table in the following manner:

58	41	40	21	23	24	34	24	31	18
48	44	41	21	27	29	21	17	20	24
40	39	38	24	XX	17	20	15	18	26
18	26	34	34	23	21	15	18	20	29
27	31	32	17	26	18	19	29	27	18

This table has 49 values because one place in the grid was left open due to sprinkler placement. The DU of this zone can be calculated from the DU formula, where the low quarter is $49/4 = 12.25 \approx 12$. The 12 cans with the least amount of water have been highlighted and were used as the low quarter when calculating DU. From the DU formula:

$$(18+17+17+18+15+19+17+15+18+18+18+18)/12 = 17.33$$

$$(58+48+40+18+27+41+44+39+26+31+40+41+38+34+32+21+21+24+34+17+23+27+23+26+24+29+17+21+18+34+21+20+15+19+24+17+15+18+29+31+20+18+20+27+18+24+26+29+18)/49 = 27.04$$

$DU = (17.33/27.04) \times 100 = 64.1\%$. By using the grid system for recording readings, patterns emerge in the landscape. The upper left hand quarter is receiving the highest application rate and the right half of the yard is receiving the lowest application rate.

3.4.7 Application Rate

The **average application rate** is the amount of water that is applied to the irrigated area over a period of time, usually in units of in./hr. If a sprinkler system applied a layer of water 1 inch deep across an irrigated area in one hour, that system would have an application rate of 1iph. However, sprinkler systems do not apply water in a perfectly uniform pattern over the entire landscape. The **effective application rate** accounts for the uniformity with which water is applied. Average application rates and effective application rates will be calculated from data collected in the field. Depending on the data that is available, there are several ways to calculate these application rates.

The application rate can be determined by either the catch can test or the flow rate method from section 3. Use the following formula to calculate the average application rate from the DU test:

$$\text{Average application rate} = \frac{\text{Volume}}{D^2 \times \text{time}} \times 4.66$$

Where:

<i>Average application rate</i>	=	[in/hr.]
<i>Volume</i>	=	Average volume of water collected per catch [ml]
<i>D</i>	=	Diameter of the top of the catch can [in]
<i>time</i>	=	Time of zone operation [min]
4.66	=	Constant which converts ml/in ² min into in/hr.

The 4.66 constant is derived by the following equation:

$$\frac{\text{ml}}{\text{min}} \times \frac{60 \text{ min}}{1 \text{ hr}} \times \frac{1 \text{ in}^3}{16.39 \text{ ml}} \times \frac{4}{\pi} = 4.66$$

Use the following formula to calculate the average application rate from the water meter recording water usage in gallons:

$$\text{Average application rate} = \frac{\text{Volume}}{\text{Area} \times \text{time}} \times 5775$$

Where:

<i>Average application rate</i>	=	[in/hr.]
<i>Volume</i>	=	Average volume of water collected per catch [ml]
<i>Area</i>	=	Irrigated area [ft ²]
<i>time</i>	=	Time required for needle in water meter to make one complete revolution [sec]
5775	=	Constant which converts gal/ft ² sec into in/hr.

The 5775 constant is derived by the following equation:

$$\frac{gal}{ft^2 \times sec} \times \frac{3600 sec}{1 hr} \times \frac{231 in^3}{1 gal} \times \frac{1 ft^2}{144 in^2} = 5775$$

Use the following formula to calculate the average application rate by recording the initial and final meter readings:

$$Average\ application\ rate = \frac{Final\ reading - Initial\ reading}{Area \times Operating\ time} \times 96.25$$

Where:

<i>Average application rate</i>	=	[in/hr.]
<i>Final reading</i>	=	Water meter value after system is turned off [gal]
<i>Initial reading</i>	=	Value at meter before system is turned on [gal]
<i>Area</i>	=	Irrigated area [ft ²]
<i>Operating time</i>	=	Duration that zone was operated [min]
96.25	=	Constant which converts gal/ft ² min into in/hr.

The 96.25 constant is derived by the following equation:

$$\frac{gal}{ft^2 \times min} \times \frac{60 min}{1 hr} \times \frac{231 in^3}{1 gal} \times \frac{1 ft^2}{144 in^2} = 96.25$$

The average application rate calculated by either this method or the flow rate method does not take into account that water is not distributed evenly across the landscape. The effective application rate should be used when calculating how long to operate the system. The effective application rate is defined by the following formula:

$$Effective\ application\ rate = Average\ application\ rate \times DU$$

Catch Can Test

YES NO

Are dry spots or areas of poor coverage visible?

Data sheet:

$$\text{Total average} = \frac{\text{Sum of all catch cans}}{\text{Total number of catch cans}}$$

$$\text{Average of low } \frac{1}{4} = \frac{\text{Sum of low } \frac{1}{4} \text{ catch cans}}{\text{Number of catch cans}}$$

$$DU = \frac{\text{Average of low } \frac{1}{4}}{\text{Total Average}}$$

$$\text{Average application rate} = \frac{\text{Volume}}{D^2 \times \text{time}}$$

$$\text{Effective application rate} = \text{Average application rate} \times DU$$

Is the DU ≥ 70% YES No

3.5 Plant Watering Requirements and Operating Times

There are various methods to determine plant watering requirements. One method is based on evapotranspiration, where the irrigation time is determined by how much water is actually used by the landscape. Although this method can take into account many factors such as plant type and differing ET rates for different times of year, it is also very time consuming. As a simplification assume that 0.25 or 0.5 inches of water is adequate per application. Most areas of Florida will use the 0.5 inch criteria. In some areas of south Florida, the soil is only a few inches deep until limestone bed rock is reached. In these areas 0.25 inches of water is adequate to fill the soil. This section of the manual outlines how long to recommend operating an irrigation system based on this criteria.

The Net Irrigation Requirement for St Augustine and Bermuda grass in South Florida 30-35 in/yr in North Florida 20-25 inches/year according IFAS documentation.

$$\text{Watering time} = \frac{0.5 \text{ or } 0.25 \text{ inches}}{\text{Effective application rate}}$$

NOTE: If the DU is less than 50% do not recommend applying excess water to compensate for poor uniformity. If the DU is less than 50%, use 50% to determine the effective application rate and calculate the recommended operating times.

As a general rule for north and central Florida use the following irrigation schedule.

Months	Turf Zones	Non-turf Zones
April through September	1 day per week	1 day every other week
October through March	2 days per week	1 day per week

The five (5) Water Management Districts throughout the various regions of the state may have more frequent irrigation schedules for your area. Contact the local Water Management District for the irrigation schedule that applies to your area.

The tables above take into account lower evapotranspiration rates for the cooler months. To determine how long to operate one zone using this method:

1. Determine the average application rate from either the flow rate method or catch can method. If no water meter is present then the application rate will have to be measured or estimated.
2. Calculate the effective application rate from the DU. If a DU test was not conducted, estimate DU. Depending on spacing, DU will usually fall between 50-60%.
3. Assume the water requirement is 0.25 or 0.5 inches, depending on the depth of soil.
4. Calculate the irrigation duration by dividing the water requirement (0.25 or 0.5 inches) by the effective application rate.

5. Multiply this number by 60 to determine the number of minutes recommended for an irrigation cycle. If the recommended operating time is longer than the controller will allow, multiple irrigation cycles will be required.
6. Finally, for rotor zones make sure that the average application rate is less than the infiltration rate. If the infiltration rate is less than the application rate then multiple watering cycles will be required to prevent runoff. For example, a steeply sloped front yard may require 40 minutes of watering from a particular system. If the infiltration rate < average application rate, then water for two twenty minute cycles separated by at least an hour to allow water from the first application time to absorb.

NOTE: Some mechanical controllers have maximum operating times of 30-45 minutes per zone. If a zone requires longer than the controller will allow, multiple cycles are necessary to achieve adequate irrigation.

Example

Given:

A system produces a flow rate of 15 gpm in one zone. This was determined by using a stopwatch and observing the water meter. A 1200 ft² area is being watered. Although a catch can test was not conducted, coverage appears to be uniform and no maintenance problems are visible. DU is estimated to be 60%.

Find:

Calculate the appropriate operating time for this zone.

Solution:

From the application rate equation, the average application rate is 1.2 in./hr.

$$[15 \text{ gallons} / (1200 \text{ ft}^2 \times 60 \text{ sec})] \times 5775 = 1.2 \text{ in./hr.}$$

The effective application rate is 0.72 in./hr..

$$1.2 \text{ in./hr.} \times 0.60 = 0.72 \text{ in./hr.}$$

The appropriate irrigation duration is 0.69 hr.

$$0.5 \text{ inches} / 0.72 \text{ in./hr.} = 0.69 \text{ hr.}$$

Irrigation time in minutes is 41 min

$$0.69 \text{ hr.} \times 60 \text{ min/hr.} = 41 \text{ min}$$

3.6 Water Usage for Urban Irrigation Systems

To determine the current water use per zone, multiply the flow rate per zone by the number of minutes the zone is operated per irrigation cycle. The flow rate from each zone can be determined using the water meter and stopwatch method as discussed in Section 2.2. To use the meter method, turn one zone on and record the time required for the needle on the water meter to

make one complete revolution. If water meter records units of gallons, use the following equation:

$$Flow\ rate = \frac{10\ gallons}{time} \times 60$$

If water meter records units of cubic feet:

$$Flow\ rate = \frac{7.4805\ gallons}{time} \times 60$$

Where:

Flow rate = Flow through a particular zone [gpm]
time = Time required for the needle on the meter to make one complete revolution [sec]

If no water meter is present then the flow rate will have to be measured or estimated. Determine the total flow rate for each zone by measuring or estimating the flow rate from each individual sprinkler and adding them together.

Water used per operating cycle is calculated by the following equation:

$$Current\ usage = Flow\ rate \times time$$

Where:

Current usage = Total water used for a zone per irrigation cycle [gal]
Flow rate = From above equation [gpm]
time = Time each zone is operated during a scheduled irrigation cycle [min]

Potential savings occur by either reducing the flow rate for a given zone and/or by reducing the operating time. Flow rate is reduced by capping sprinklers or changing to low flow systems. Provide the property manager with an estimate of water use from schedule changes alone, as well as system changes. If only the operating time on a given zone is reduced then the new water use can be determined by the following equation:

$$Net\ water\ use = Flow\ rate \times Recommended\ time$$

Where:

New water use = Total water used for a zone per irrigation cycle [gal]
Flow rate = From previous page [gpm]
Recommended time = Duration for which a specific zone should operate [min]

If sprinklers are capped or low flow components are installed, then use manufacturers' catalogs to estimate the change in the flow rate. Recommending operating times for existing systems is a straight forward process. However, if a system is altered by adding sprinklers then the effective

precipitation rate may increase and the required operating time may decrease. There is no set rule for determining how to calculate the appropriate irrigation time for proposed system changes. Changing the system invariably alters uniformity, application rate, and pressure.

As an estimation, use the method from section 2.2.1 to determine the application rate. (For example, if a 5 gpm rotor is being added to a zone already delivering 17 gpm then the new average application rate can be determined by dividing the total flow rate by the area irrigated.)

$$\text{New average application rate} = \frac{\text{Current flow rate} \pm \text{proposed changes}}{\text{Area Irrigated}} \times 96.25$$

Where:

<i>New average application rate</i>	=	Average applied rate after system is altered [in/hr.]
<i>Current flow rate</i>	=	Flow rate through meter with current system design [gpm]
<i>Proposed changes</i>	=	Flow rates added or subtracted depending upon whether or not sprinklers are added to the system or capped [gpm]
<i>Area irrigated</i>	=	Area being watered [ft ²]

Recommend how long to operate the irrigation system based on a 0.5 inch application of water and an estimated improved DU of 60% to 70%. Determine a new effective application rate by multiplying the new average application rate by the estimated DU.

$$\text{New effective application rate} = \text{New average application rate} \times \text{Improved DU}$$

Calculate the suggested operating times for each zone in the current irrigation system as discussed in section 5.6, and each zone in which system changes have been recommended.

The total water used for each zone before and after recommendations can be determined by multiplying the original operating time by the original flow rate and the new flow rate by the new suggested operating time, respectively.

Example 1

Given: A system is currently delivering 12 gpm at a pressure of 40 psi. The area irrigated is 1,500 square feet of medium sand. The current coverage is not very even, so estimate the DU to be 0.50. To improve coverage, it is recommended adding a 90° Hunter G-Type rotor with a #5 nozzle. The new coverage will be improved, so estimate the improved uniformity to be 0.75.

Determine: The current average and effective application rates, recommended irrigation duration using the root zone method, and the water used for one irrigation cycle using the original design. Calculate the new average application rate, the new irrigation duration and the amount of water used for the improved design.

Solution:

Current average application rate:
 $(12 \text{ gpm}/1500 \text{ ft}^2) \times 96.25 = 0.77 \text{ in./hr.}$

Current effective application rate:
 $0.77 \text{ in./hr.} \times 0.50 = 0.385 \text{ in./hr.}$

Recommended irrigation duration:
Water requirement = 0.5 inches
Irrigation duration = $0.5 \text{ inches}/0.385 \text{ in./hr.} = 1.3 \text{ hr.}$
Time in minutes = $1.3 \text{ hr.} \times 60 \text{ min/hr.} = 78 \text{ min}$

Water used per cycle:
 $12 \text{ gpm} \times 78 \text{ min} = 936 \text{ gallons}$

New average application rate:
According to the Hunter catalog the flow rate from a #5 nozzle at 40 psi is 1.8 gpm. The total flow rate for this zone will then be $12 \text{ gpm} + 1.8 \text{ gpm} = 13.8 \text{ gpm}$ and new water use should be calculated based on this flow rate is $(13.8 \text{ gpm}/1500 \text{ ft}^2) \times 96.25 = 0.90 \text{ in./hr.}$

New effective application rate:
 $0.886 \text{ in./hr.} \times 0.75 = 0.664 \text{ in./hr.}$
Recommended irrigation duration:
 $0.5 \text{ inches}/0.664 \text{ in./hr.} = 0.75 \text{ hr.}$
 $0.75 \text{ hr.} \times 60 \text{ min/hr.} = 45 \text{ min}$

Water used per cycle:
 $13.8 \text{ gpm} \times 45 \text{ min} = 621 \text{ gal}$

Example 2.**Given:**

A zone consisting entirely of spray heads is watering turf and Indian Hawthorn shrubs. The zone is currently delivering 15 gpm. Because Indian Hawthorn is natural and does not require supplemental watering, it is recommended capping 3 180° Series 12 Rain Bird spray nozzles. Due to difficulty in measuring dynamic system pressure of spray head zones, the operating pressure must be estimated. If the system is operating properly, and pop-up risers are not leaking, assume that system pressure is 30 psi. The zone currently operates for 10 minutes, and will continue to operate for 10 minutes after sprinklers are capped.

Determine:

The water used per irrigation cycle before and after the three sprinklers are capped.

Solution:

Original water use = 15 gpm x 10 min = 150 gal

According to the Rain Bird catalog, 180°, Series 12 Rain Bird spray nozzles deliver 1.3 gpm

New flow rate = 15 gpm – 3 x (1.3 gpm) = 11.1 gpm

New water use = 11.1 gpm x 10 min = 111 gal

3.7 Presentation of Urban Evaluation Results

The manner in which results are reported will vary depending on the goals of the agency conducting the urban irrigation evaluations. Some reports may emphasize system management, while others will more strongly favor system design improvements. In either case there is certain key material which should be included with each type of evaluation.

3.7.1 Visual Inspection

The visual inspection is a basic evaluation and is designed to be a preliminary screening tool to target areas for future evaluations. The report generated from the visual inspection should include the check box evaluation forms.

Fact sheets such as proper mowing height, watering restrictions, and Best Management Practices (BMPs) for turf and landscape should be included with the report.

3.7.2 Pressure and Flow

The report generated from pressure and flow data is more detailed than the visual inspection report. The pressure and flow report will include the average application rate as well as an estimate of the effective application rate. The report will also include recommendations for system improvements on a zone-by-zone basis.

Once the effective application rate is estimated, this report will include a suggested irrigation schedule based on data collected in the field as well as site observation that indicate over watering or under watering.

Finally, this report will include an analysis of current water usage and potential water savings. Water usage should be calculated for recommended operating times alone, as well as recommended operating times combined with system improvements.

3.7.3 Catch Can Test

The report generated from catch can data is also more detailed than the visual inspection report. The catch can test report will include the average application rate as well as the calculated effective application rate for at least one zone. The report will also include recommendations for system improvements on a zone-by-zone basis.

Once the effective application rate is calculated, this report will include a suggested irrigation schedule based on data collected in the field as well as site observation that indicate over watering or under watering.

Finally, this report will include an analysis of current water usage and potential water savings. Water usage should be calculated for recommended operating times alone, as well as recommended operating times combined with system improvements.

3.8 Steps to Conducting an Evaluation

The following is a description of the field procedure for evaluating urban sprinkler irrigation systems.

1. Select a date and time so the landowner will be available to walk through the entire sprinkler system.
2. Locate and determine the water source. (Municipal, well, reclaimed, pond, or lake)
3. Record the irrigation controller settings.
4. Check the irrigation controller for lithium or battery back-up.
5. Run all irrigation zones and flag all sprinklers. If system is too large flag sprinklers in representative zones.
6. While flagging sprinklers determine the best representative zone suited for the catch can test.
7. Locate catch cans and space evenly throughout the test area.
8. Check and record nozzles, makes and models used in test area.
9. Run catch can area. The run time should be so that each catch can has at least 5ml to measure.
10. Record all water caught in catch cans and remove low-quarter mean.
11. Determine (DU) Distribution Uniformity.
12. Once the (DU) Distribution Uniformity is determined run zones and record all data and data sheets (makes, models, pressures and areas.
13. For Municipal systems each zone should be timed for an actual flow rate per zone.
14. For Well and Pump systems count all sprinklers and record all types, makes and models and pressures to determine flow per zone.
15. Determine soil type by referencing the county soil survey or by using the NRCS" feel and appearance" method.
16. Determine the turf root depth.
17. Determine the Net Irrigation requirement for turf (Zoysia, St. Augustine, Bermuda and Bahia). For St Augustine and Bermuda grass in South Florida 30-35 in/yr in North Florida 20-25 in/yr (IFAS).
18. Determine average application rate.
19. Determine distribution uniformity.
20. Determine effective application rate.
21. Calculate operating time.
22. Determine water usage.
23. Make system recommendations.

3.8.1. Determine Average Application Rate

The **average application rate** is the amount of water that is applied to the irrigated area over a period of time, usually in units of inches per hour (in/hr.). If a sprinkler system applied a layer of water 1 inch deep across an irrigated area in one hour, that system would have an application rate of 1iph. However, sprinkler systems do not apply water in a perfectly uniform pattern over the entire landscape. The **effective application rate** accounts for the uniformity with which water is applied. Average application rates and effective application rates will be calculated from data collected in the field. Depending on the data that is available, there are several ways to calculate these application rates.

3.8.2. Meter Records Water Use in Gallons

Turn one zone on and use a stop watch to record the time required for the needle on the water meter to make one complete revolution. The average application rate is determined by the following equation:

$$\text{Average application rate} = \frac{\text{Volume}}{\text{Area} \times \text{Time}} \times 5775$$

Where:

<i>Average application rate</i>	=	in/hr.
<i>Volume</i>	=	Volume required for needle in water meter to make one complete revolution [gal]
<i>Area</i>	=	Irrigated area [ft ²]
<i>Time</i>	=	Time required for needle in water meter to make one complete revolution [sec]

If a sprinkler system applies 10 gallons of water to 1000 square feet in 30 seconds, that system will have an average application rate of 1.925 in/hr.

$$[10 \text{ gal} / (1000 \text{ ft}^2 \times 30 \text{ sec})] \times 5775 = 1.925 \text{ in/hr.}$$

Another method can be used to determine the average application rate. Record the meter reading with the system turned off. Turn one zone on for a specified period of time (1 or 2 minutes) then turn the system off and record the meter reading again. The average application rate can be calculated by the following equation:

$$\text{Average application rate} = \frac{\text{Final reading} - \text{Initial reading}}{\text{Area} \times \text{Operating time}} \times 96.25$$

Where

<i>Average application rate</i>	=	[in/hr.]
<i>Final reading</i>	=	Water meter value after system is turned off [gal]
<i>Initial reading</i>	=	Value taken at meter before system is operated [gal]
<i>Area</i>	=	Irrigated area [ft ²]

Time = Duration that zone was operated [min]

3.8.3. Meter Records Water Use in Cubic Feet

Some meters will have cubic feet instead of gallons, where one revolution of the water meter is 1 cubic foot. For these systems use the above equations, but multiply the final answer by 7.481. This will convert the volumetric reading in the numerator from cubic feet to gallons.

1 cubic foot = 7.481 gallons

3.8.4. No Meter is Present

Some urban irrigation systems may be supplied by a well, and may not have water meters installed. In such a system the flow rate must be determined at each sprinkler, and the entire flow rate for a zone is determined by adding up all the individual flow rates. The total flow rate will then be divided by the area to find the average application rate.

There are two ways to determine the flow rate from a sprinkler. One way is to determine the pressure from a sprinkler, then compare that pressure with the manufacturers catalog to see what flow rate is associated with that pressure.

Pressure on rotor zones is determined by turning the system on holding a pitot tube attached to a pressure gauge in the stream of the rotor, about 1/8 of an inch from the nozzle. Pressure on spray head zones can be determined by installing a pressure gauge in line between the pop-up riser and the nozzle of a spray head sprinkler. There is no tool commercially available to make this measurement, but some NRCS field offices have constructed their own. The pressure should be checked at the first and last spray head in a zone.

Another method used is to measure the flow rate from a sprinkler using a stopwatch and some catchment such as a bucket. Flow rate should be measured on each sprinkler by placing a bucket in front of the rotor stream or spray nozzle for a timed duration using a stop watch. Measure the water collected using a 1000 ml graduated cylinder. Determine the flow rate from the following equation:

$$Flow\ rate = \frac{Volume}{Time} \times 0.01585$$

Where:

Flow rate = Gallons per minute [gpm]
Volume = Volume collected [ml]
Time = Time that water was collected [sec]

The average application rate is then determined using the following equation:

$$Average\ application\ rate = \frac{Total\ flow\ rate}{Area} \times 96.25$$

Only a catch can test is conducted (no pressure and flow)

Use the following formula to calculate the average application rate from the DU test:

$$\text{Average application rate} = \frac{\text{Volume}}{D^2 \times \text{time}} \times 4.66$$

Where:

<i>Average application rate</i>	=	in/hr.
<i>Volume</i>	=	Average volume of water collected per catch [ml]
<i>D</i>	=	Diameter of the top of the catch can [in]
<i>time</i>	=	Time of zone operation [min]

3.8.5. Determine Distribution Uniformity

$$DU = \frac{\text{Low } \frac{1}{4} \text{ average}}{\text{Total average}} \times 100$$

Where:

<i>DU</i>	=	Distribution uniformity in percent [%]
<i>Low quarter average</i>	=	Average volume in the 25% of cans that received the least water [ml]
<i>Total average</i>	=	Average volume of all cans [ml]

If no DU test is conducted, an estimate of 50% to 70% should be assumed based on spacing and system layout.

3.8.6. Determine the Effective Application Rate

$$\text{Effective application rate} = \text{Average application rate} \times DU$$

3.8.7. Calculate Operating Time

$$\text{Watering time} = \frac{\text{Plant water requirement}}{\text{Effective application rate}} \times 60$$

Where:

<i>Watering time</i>	=	Suggested time that a zone should be operated [min]
<i>Plant watering requirement</i>	=	0.5 or 0.25 depending on location [in]
<i>Effective application rate</i>	=	From Step 3 [in/hr.]

3.8.8. Determine Water Used per Operating Cycle

Water used per operating cycle is calculated by the following equation:

$$\text{Current usage} = \text{Flow rate} \times \text{time}$$

Where:

<i>Current usage</i>	=	Total water used for a given zone per irrigation cycle [gal]
<i>Flow rate</i>	=	Determined from equations below [gpm]
<i>time</i>	=	Time a zone is operated during a scheduled irrigation cycle [min]

If water meter records units of gallons, use the following equation:

$$\text{Flow rate} = \frac{10 \text{ gallons}}{\text{time}} \times 60$$

If water meter records units of cubic feet:

$$\text{Flow rate} = \frac{7.48 \text{ gallons}}{\text{time}} \times 60$$

Where:

<i>Flow rate</i>	=	Flow through a particular zone [gpm]
<i>time</i>	=	Time required for the needle on the meter to make one complete revolution [sec]

If no water meter is present, determine the flow rate from each sprinkler within one zone and add them all together.

$$\text{Flow rate} = \frac{\text{Volume}}{\text{time}} \times 0.01585$$

Where:

<i>Flow rate</i>	=	Gallons per minute [gpm]
<i>Volume</i>	=	Volume collected [ml]
<i>Time</i>	=	Time that water was collected [sec]

3.8.9. Make System Recommendations

Provide the homeowner with an estimate of water use from schedule changes alone, as well as system changes. If only the operating time on a given zone is reduced then the new water use can be determined by the following equation:

$$\text{New water use} = \text{Flow rate} \times \text{Recommended time}$$

Where:

<i>New water use</i>	=	Total water used for a given zone per irrigation cycle [gal]
<i>Flow rate</i>	=	From Step 5 [gpm]

Recommended time = Duration for which a specific zone should operate [min]

If changes are recommended for the system, calculate a new average application rate based on flow changes in the system. Estimate changes in flow from manufacturer's catalogs.

$$\text{New average application rate} = \frac{\text{Current flow rate} \pm \text{proposed changes}}{\text{Area irrigated}} \times 5775$$

Where:

New average application rate = Average applied rate after system is altered [in/hr.]
Current flow rate = Flow rate through meter with current system design [gpm]
proposed changes = Flow rates added or subtracted depending upon whether sprinklers are added or capped [gpm]
Area irrigated = Area being watered [ft²]

Recommend how long to operate the irrigation system based on a 0.25 or 0.5 inch application of water and an estimated improved DU of 60% to 70%. Determine a new effective application rate by multiplying the new average application rate by the estimated DU, as shown in step 3. Determine a new operating time and calculate water usage as shown in steps 4 and 5 respectively.

3.9 Typical Problems and Recommendations for Urban Irrigation Systems

Problems are irrigation system or management factors that limit irrigation system performance or efficiency. Problems are noted during the site visit, system evaluation, and/or through discussions with the operator.

The following items listed below are recommendations that may be given to the landowner to address the problems identified above:

1. Sprinklers should be spaced according to the manufacturer's specifications.
2. Minimum pressure should be no lower than (25psi).
3. Keep rotary sprinklers separate from spray heads.
4. Rotary sprinklers should have matched nozzles for matched precipitation rates (MPR).
5. Keep turf separate from landscaped areas.
6. Retrofit low volume alternatives for watering of shrub beds
7. Irrigate in the pre-dawn hours of the day to reduce evaporation.

Automatic rain shut off device should be installed and operating.

3.10 Reporting Results of Urban Irrigation Evaluations

The results for the three types of reports are presented differently. The visual inspection or level one evaluation is presented as a checklist shown in Section 3.1 of the text. The report from a

catch can evaluation requires the most time. This report addresses specific recommendations on a zone-by-zone basis.

Pressure and Flow Report

The report generated from the pressure and flow inspection provides the property manager with qualitative information about their system. The pressure and flow report addresses topics of landscape maintenance, irrigation system maintenance, scheduling, material, design and planning. The first example of a pressure and flow report is presented on page 3-37 as a series of check boxes to provide general comments about the system as well as a section for zone by zone improvements. Some examples of zone by zone recommendations are as follows.

Zone 1

- Move the rotor in the southwest corner of the front yard closer to the edge of the sidewalk to improve coverage in this area.
- Replace the #5 nozzle in the center 360° rotor with a #9 nozzle for increased system uniformity.

Zone 2

- Prune lower branches of the oak tree on the north side of the back yard to reduce excessive blockage of the irrigation stream.
- Cap the 90° rotor in the north east corner of the backyard. This entire area is natural shrubs and trees and does not require supplemental watering.

Zone 3

- This zone consists of a small strip of turf along the side of the house. Replace the turf in this area with a natural ground cover such as Dwarf Confederate Jasmine. Mulch or stepping stones can be used to provide a walkway from the front yard to the back. Once established, this zone can be turned off completely.

The second example presented on page 3-42 is a point system developed by retired NRCS District Conservationist Jack Creighton, and provides a method for rating the system being tested. It has been a useful tool when conducting residential evaluations.

Urban Irrigation Water Management Report

Customer: _____

Note: If there is a recommended correction for your system in the following report, a check will appear in the appropriate box.

Landscape Maintenance

- 1. Trim branches or twigs that are blocking emitter streams.
- 2. Remove non-functional trees and shrubs that block emitter streams.
- 3. Remove grass immediately around sprinklers so the irrigation stream is not blocked.
- 4. Remove narrow strips of turf and replace them with mulch or a natural ground cover.
- 5. Apply mulch in non-turf areas to a depth of 4 inches to hold moisture, reduce weeds, erosion, and add organic matter to the soil.
- 6. When planting trees or shrubs select natural or drought-tolerant plants, adequate mulch and low flow irrigation devices.

Irrigation System Maintenance

- 1. Include time to locate and repair clogged or leaking sprinklers and lines.
- 2. Monitor pressure reducing and flow restricting devices for proper function.
- 3. Low pressure in the system can be corrected by capping unnecessary sprinklers, changing to low volume emitters where possible, and discovering and repairing hidden leaks.
- 4. Place protective concrete donuts around sprinklers and show their location to lawn maintenance personnel.
- 5. Adjust or replace directional spray emitters to avoid watering non-irrigated area (driveways, sidewalks, etc.).

Irrigation System Schedule

- 1. A precise irrigation schedule requires observation, a rain gauge and rain sensor. Recommended watering times are based on system examination, soil type, and observations. Skip designated irrigation times when soil has sufficient moisture. Watch turf and shrubs for signs of stress.
- 2. Turn off sprinklers on mature natural or drought tolerant trees and shrubs. As sprinklers are capped, visually inspect other sprinklers on the same zone for excessive pressure.

Irrigation System Equipment/Materials

- 1. Install a rain-shut-off sensor. They save water by turning the system off after sufficient rainfall.
- 2. A rain gauge can provide more useful information than a rain-shut-off sensor. By knowing how much rainfall has occurred, it can be determined how long to wait until your next irrigation cycle.
- 3. A well filter will help reduce clogging of sprinklers caused by debris.
- 4. Concrete donuts protect sprinklers from damage by vehicles and mowers.
- 5. Proper use of risers will reduce stream interference caused by shrubs.
- 6. Coring tools aid in determining the soil moisture content when watering on an as-needed basis.
- 7. Update the current controller to one that offers more options for scheduling, such as independent programs for turf and non-turf areas.

Irrigation System Planning and Design

- 1. Adjust or relocate sprinklers to achieve head-to-head coverage
- 2. Any new zones should be planned as either turf or non-turf zones. One zone should not water both turf and non-turf areas.
- 3. Rotors and pop-up spray heads should be placed on separate zones to reduce over watering.
- 4. Use the same manufacturer for all rotors and spray heads.
- 5. Low volume irrigation devices should be installed in plant beds so that less water is applied to beds than turf.
- 6. Include drought-tolerant plants in non-turf areas to reduce the water demand of your landscape.

Recommendations:

Zone 1:

Zone 2:

Zone 3:

Zone 4:

Zone 5:

Zone 6:

Irrigation Duration:

Water use per operating cycle.

Zone	Current Water Usage	Actual Water Savings Based upon On-site Schedule Changes Only	Potential Water Saving Based upon System Improvements and Schedule Changes
Zone 1			
Zone 2			
Zone 3			
Zone 4			
Zone 5			
Zone 6			
Total			

Urban Irrigation Water Management

Rating System

Evaluator _____ Date / / .

Site Name _____ Phone () .

Address _____.

Subject	Point Value (circle)	Total
Devices (65 Points)		
Utilizes coring tool (wetness)	25	
Proper rain or soil moisture sensor	20	
Utilizes rain gauge	15	
Protection for sprinklers (Donuts)	5	<input type="checkbox"/>
Schedule (25 Points)		
Does not exceed 0.5 inches application per watering	25	<input type="checkbox"/>
System (75 Points)		
Filter at well	25	
No system leaks	25	
Minimum pressure at farthest head at least 25 psi	25	<input type="checkbox"/>
Zones (50 Points)		
Plant beds on separate zones from turf	25	
rotors in separate zones from spray heads	25	<input type="checkbox"/>
Drought Tolerant Landscaping (25 Points)		
Uses drought tolerant shrubs and ground covers	25	<input type="checkbox"/>
Turf (30 Points)		
Irrigation stream clear of obstacles	15	
Drought tolerant grass	15	<input type="checkbox"/>
Beds (80 Points)		
Four inches or more of mulch	20	
Low volume emitters	20	
Irrigation stream clear of obstacles	15	
Irrigation heads turned off at mature shrubs	10	
Sufficient use of risers	10	
Proper directional emitters (90°, 180°)	5	<input type="checkbox"/>

Irrigation Heads (75 Points)

Proper head to head coverage	25	
Matched emitters	25	
Sprinkler position (upright)	10	
All from same manufacturer	5	
Undamaged	5	
Unclogged	5	<input type="checkbox"/>

Operator Knowledge (15 Points)

Understanding of water source (well, pond, municipal)	1	
“As built” orientation	1	
Command of the control box	1	
Understanding pressure	1	
Understanding flow (nozzle sizes)	1	
Sprinkler distribution (degrees)	1	
Sprinkler distribution (distance)	1	
Changing spray nozzles	1	
Rotor sprinkler adjustment	1	
Maintenance for pop-up spray heads	1	
Understanding of rain sensor and gauge	1	
Understanding benefits of drought tolerant landscape	1	
Knowledge of specific drought tolerant plants	1	<input type="checkbox"/>

Operation Summary

Item	Maximum Value	Score
Devices	65	_____
Schedule	25	_____
System Water Pressure	75	_____
Zones	50	_____
Drought Tolerant Landscape	20	_____
Turf	30	_____
Beds	80	_____
Irrigation Heads	75	_____
Operator Knowledge	15	_____
Possible Score:	440	Total Score: _____

Operation Rating

Total Score (_____ /440) x 100 = _____ % is the rating

Catch Can Evaluation Report

The catch can test provides the most detailed information about an irrigation system. The report generated from data collected should provide property managers with precise information about their irrigation system. The report is similar to the report generated from the pressure and flow evaluation with a few pieces of additional information. Include calculations of distribution uniformity, effective application rate, current water used as well as potential savings. Also include zone by zone recommendations of any system or landscape changes.

Irrigation Duration:

Water use per operating cycle.

Zone	Current Water Usage	Actual Water Savings for Based upon On-site Schedule Changes Only	Potential Water Saving Based upon System Improvements and Schedule Changes
Zone 1			
Zone 2			
Zone 3			
Zone 4			
Zone 5			
Zone 6			
Total			

Distribution uniformity in zone tested: %

Average application rate in zone tested: in/hr.

Effective application rate in zone tested: in/hr.

Chapter 4 — Water Conservation Report

4.1 Introduction

The MILs who actively participate in the Statewide MIL ICC and adhere to the MIL-TH have received training to provide a variety of recommendations to an owner or operator of an irrigation system in conserving irrigation water. These recommendations can vary from the utilization of soil moisture sensors, to repairs, to modifications in the irrigation schedule, to a new irrigation system, depending on the type of irrigation system being used and managed.

Not all of these recommendations lend themselves at this time to an MIL quantifying the potential or actual water saved from each of them. Therefore, at this time the MILs are documenting water savings for the following scenarios: the improvement of the DU or EU of the irrigation system itself and/or its associated actual or potential reduction in irrigation system run time (irrigation schedule); irrigation scheduling changes; and the potential or actual repair of leaks and/or irrigation system components.

More methods to document actual or potential water savings under other scenarios will be added to this MIL TH as the MILs are trained on their implementation, and the methods are recognized as valid by the ICC and its partners, the irrigation industry and the research community.

4.2 Determining the Maximum and Actual Distribution and/or Emission Uniformities of a Pressurized Pipe Irrigation System

DU and EU were already discussed in Chapter 2 of this Handbook; so did Potential or Maximum DU or EU. Therefore, the reader is encouraged to review Chapter 2 regarding those topics.

Each type of pressurized pipe irrigation system has the potential to achieve a Maximum DU or EU. That potential or maximum DU or EU has been identified over the years for each irrigation system via a record of on-going tests done by irrigation manufacturers, the research community and/or the MILs themselves. Such information is summarized in table 4 below. Since newly introduced irrigation system components, techniques, and/or technologies could improve those optimum or maximum EU's or DU's in the future, Table 4 will need to be updated accordingly.

In order for a maximum EU or DU to be changed in Table 4 the MILs must have obtained themselves a history of those same maximum/optimum values via numerous evaluations of their own, to verify that such new EU's or DU's can in fact be obtained under Florida conditions. Such history shall be kept by each MIL in a separate folder entitled "Log of Maximum DU's or EU's and presented to the MIL ICC for discussion and approval, before any maximum/optimum DU or EU numbers are changed in Table 4. Only until those values are changed in Table 4 and the MIL-TH is officially revised by the MIL ICC, will any MIL be allowed to use such revised values to calculate PWS or AWS.

Table 4 – Maximum Potential System Uniformity



















Irrigation Method/System		Maximum Potential System DU or EU
Sprinkler Irrigation (Traveling Gun)		65
Sprinkler Irrigation (Periodic Move gun type or boom sprinklers)		60
Sprinkler Irrigation (Hand move Portable)		75
Sprinkler Irrigation (Solid Set)		86
Sprinkler Irrigation (Center Pivot, Standard)		85
Sprinkler Irrigation Low Pressure Nozzles (LPN) –(center pivot and lateral move)		94
Sprinkler Irrigation Low Energy Precision Application (LEPA) Center Pivot or Linear Move		95
Sprinkler Irrigation (Linear Move)		87
Sprinkler Irrigation (Periodic Move Lateral)		75
Microirrigation (Spray Emitters)		95
Microirrigation (Point Source Emitters)		90

Table 4 – Maximum Potential System Uniformity

Irrigation Method/System		Maximum Potential System DU or EU
Microirrigation (Line Source Emitters)		90
Microirrigation (Subsurface Drip Irrigation (SDI))		92
Open Ditch (Irrigating Laterals and Furrows) (Flow Through)		80
Open Ditch (Irrigating Laterals and Furrows) (Backup)		75
Open Ditch (Irrigating Laterals and Furrows) (Crown Flood)		80
Subirrigation – Subirrigated (Underground Conduit)		85
Surface Irrigation, Graded Furrow		80
Surface Irrigation, Level Furrow		85

References:

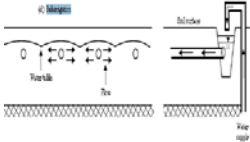
1. NRCS NEH, Part 652, NIG, Chapter 15, Florida Supplement, Table FL15 – 1, NRCS Farm Irrigation Rating Index
2. Minutes from May 4 and 5 2010 MIL ICC Meeting

Chapter 2 of this Handbook identifies the procedures all MILs are to follow to determine the actual DU or EU of any pressurized irrigation system. Part of those procedures are associated with the following equations, which are also in Chapter 2 and are taken from NRCS NEH Part 652, Irrigation Guide, Chapter 9 and Chapter 3 of this Handbook.

DU:

For Center Pivots:

$$DU (\%) = \left(\frac{\text{Weighted low } \frac{1}{4} \text{ average application}}{\text{Weighted system average application}} \right) \times 100$$

$$\text{Weighted low } \frac{1}{4} \text{ average application (in)} = \frac{\text{Sum Low } \frac{1}{4} \text{ weighted catches}}{\text{Sum low } \frac{1}{4} \text{ factors}}$$

$$\text{Weighted system average application (in)} = \frac{\text{Sum all weighted catches}}{\text{Sum all position #'used}}$$

For Linear Move, Periodic Move, and Fixed Solid Set Sprinklers:

$$DU (\%) = \left(\frac{\text{Average low } \frac{1}{4} \text{ depth of water recieved}}{\text{Average depth of water recieved}} \right) \times 100$$

EU:

For Microirrigation Systems:

$$EU (\%) = \left(\frac{\text{Minimum rate of discharge per plant}}{\text{Average rate of discharge per plant}} \right) \times 100$$

Application:

$$\text{Average Application Rate (in/hr)} = \frac{\text{volume collected (ml)}}{\text{area} \times \text{time}} \times 5775$$

OR

$$\text{Average Application Rate (in/hr)} = \frac{\text{total discharge per sprinkler (gpm/spk)}}{\text{Area (sq.ft.)}} \times 96.3$$

OR

If a water meter is present, another method can be used to determine the average application rate. Record the meter reading with the system turned off. Turn one zone on for a specified period of time (1 or 2 minutes) then turn the system off and record the meter reading again. The average application rate can be calculated by the following equation:

$$\begin{aligned} & \text{Average Application Rate (in/hr)} \\ &= \frac{\text{final meter reading} - \text{initial meter reading}}{\text{Area (sq.ft.)} \times \text{time}} \times 96.3 \end{aligned}$$

If only a catch can test is performed (no pressure and flow check),

$$\text{Average Application Rate (in/hr)} = \frac{\text{Volume}}{D^2 \times \text{time}} \times 4.66$$

Where Volume = average volume of water collected per catch (ml)

D = diameter of the top of the catch can (in)

Time = Time of operation (min)

$$\text{Effective Application Rate (in/hr)} = \frac{DU}{100} \times \text{Average Application Rate}$$

$$\text{Irrigation Duration (minutes)} = \frac{\text{Plant Water Requirement (in)}}{\text{Effective Application Rate (in/hr)}} \times 60 \left(\frac{\text{min}}{\text{hr}} \right)$$

4.3 Calculating Potential Water Savings (PWS)

PWS is the maximum amount of irrigation water that could be saved annually, if all MIL recommendations derived from the **initial evaluation** of the irrigation system are followed by the irrigation system operator or owner.

The only time when any MIL is to determine PWS is when the MIL is conducting an **initial evaluation** of an irrigation system. Any follow up evaluations to that same irrigation system shall be used by the MIL to determine Actual Water Savings (AWS) only, which is the portion of the PWS of that same irrigation system which has actually been saved via a follow up evaluation.

For purposes of this Handbook, PWS will be divided into the following three defined categories:

PWS Due to Irrigation System Efficiency Improvements (ac-ft): The amount of irrigation water that can be saved annually by improving the DU or EU of the irrigation system, which should lead to a reduction in hours of irrigation required.

PWS Due to Irrigation System Scheduling (ac-ft): The amount of irrigation water that can be saved annually if schedule changes (run time and frequency) alone are implemented.

PWS Due to the Repair of Leaks and/or any Applicable Irrigation System Components (ac-ft): the amount of irrigation water that can be saved annually by repairing irrigation system leaks or components, or replacing faulty irrigation system components.

In order to calculate PWS, it is important to also define the following terms:

Net Irrigation Requirement (NIR, inches):

The minimum amount of irrigation water required by irrigation to satisfy plant or crop evapotranspiration and auxiliary needs that are not stored in the soil profile or precipitation annually, based on the area of the State it is grown, and the **average or normal** climatic condition under which it is grown.

For land where more than one crop is grown during the season (crop rotation), the NIR is the summation of the NIR for each crop during that 12 month period and is referred to as the Annualized NIR.

The NIR for common crops in Florida grown under **average or normal** climatic conditions can be found in NRCS NEH, Part 652, Irrigation Guide, Florida Supplement, Chapter 4. This handbook can be downloaded from the Field Office Technical Guide (FOTG), Section I., C. References, 1. Engineering References, e. Part 652, Irrigation Guide – Florida Supplement, Chapter 15, at the following web address: <http://efotg.sc.egov.usda.gov/treemenuFS.aspx>.

There are some crops/plants where no NIR has been identified by the NRCS reference listed above, but has been determined via other peer reviewed documents produced by research institutions such as IFAS or other academic or research institutions. The MILs will be allowed to use such peer reviewed NIRs as long as the documents referring to those NIRs have been officially included in the References section of this Handbook.

The Normal Year NIR is defined as:

= *Normal Year Crop water requirements (inches) – Normal Year Effective Rainfall (inches)*

Actual Water Used (AWU, Inches):

The actual amount of water used annually for irrigation of a plant or crop, based on **documented** irrigation flowmeter **and** irrigation scheduling information provided by the farmer or obtained by the MIL. **Verbal hear-say information is not acceptable AWU.**

Following are the only three acceptable ways for the MILs to document Annual Actual Water Use:

1. A complete accounting of annual water use via **documented** readings from a water meter that is working properly, has been calibrated, and is permanently installed on the irrigation system.

OR

2. A complete accounting of water use via **documented** and consistent irrigation schedules and irrigation times throughout the year, **AND** the temporary use of the MIL's portable flow meter on the irrigation system to determine its flow rate in gallons per minute.

OR

3. A complete **documentation** and accounting of **water discharged from each and all of the water application devices** in the irrigation system being evaluated (sprinklers, sprayers, drippers, etc.) **AND** leaks (if applicable) via:

- Physical catches into a cylinder, bucket or container that can be used to measure each of those catches or leaks accurately; or
- If **each and all** of the water application devices in the irrigation system being evaluated are **in good operating condition**: the physical measurement of the pressure at **each and all** of the water application devices in the irrigation system being evaluated (sprinklers, sprayers, drippers, etc.), in combination with the **official manufacturer’s** design discharge specification sheets for **each and all** of those water application devices; or
- A combination of physical catches for some water application devices and leaks, and pressure readings for the reminder application devices in that same irrigation system being evaluated, depending on the condition of each application device.

If an MIL cannot document actual water use using any of the three ways described above, then the MIL shall not use actual water use to determine PWS associated with the improvement of the DU or EU of the irrigation system being evaluated.

There are three ways in which PWS associated only with irrigation system DU or EU efficiency improvement can be calculated by the MIL, depending on the actual or estimated water use information available to the MIL at the time of the initial evaluation. Those three methods are outlined below, and are listed in the priority in which they should be used. **Only one of these three methods shall be identified and used by the MIL.** As mentioned previously in this chapter, as more methods to quantify other water conservation activities become available and are officially approved by the ICC and its partners, they will be added to this Handbook.

The PWS via an initial evaluation associated only with irrigation system DU or EU efficiency improvements, NIR, and AWU information will be quantified and documented by the MILs as follows:

PWS, Efficiency, AWU and $NIR_{(ac-ft)}$:

$$= \left(\frac{\text{Actual Water Used (in.)}}{DU \text{ or } EU_{initial \text{ eval}}} - \frac{NIR \text{ (in.)}}{DU \text{ or } EU_{max}} \right) \times \left(\frac{\text{irrigated acres}}{12} \right)$$

If the MIL chooses this method, no additional PWS associated with irrigation schedule changes can be calculated and reported by the MIL, because those are already incorporated into this method. Additional PWS associated with leak and irrigation system component repairs could still be possible, if the irrigation system being initially evaluated has such problems and they can be quantified.

The PWS via an initial evaluation associated only with irrigation system DU or EU efficiency improvements and AWU information will be quantified and documented by the MILs as follows:

PWS, Efficiency, AWU_(ac-ft):

$$= \left(\frac{\text{Actual Water Used}}{DU \text{ or } EU_{\text{initial eval}}} - \frac{\text{Actual Water Used}}{DU \text{ or } EU_{\text{max}}} \right) \times \left(\frac{\text{irrigated acres}}{12} \right)$$

If the MIL chooses this method, additional PWS associated with irrigation schedule changes can also be calculated and reported by the MIL as applicable. Additional PWS associated with leak and irrigation system component repairs could still be possible, if the irrigation system being initially evaluated has such problems and they can be quantified.

The PWS via an initial evaluation associated only with irrigation system DU or EU efficiency improvements and NIR information will be quantified and documented by the MILs as follows:

PWS Efficiency, NIR_(ac-ft):

$$= \left(\frac{NIR}{DU \text{ or } EU_{\text{initial eval}}} - \frac{NIR}{DU \text{ or } EU_{\text{max}}} \right) \times \left(\frac{\text{irrigated acres}}{12} \right)$$

If the MIL chooses this method, additional PWS associated with irrigation schedule changes can also be calculated and reported by the MIL as applicable. Additional PWS associated with leak and irrigation system component repairs could still be possible, if the irrigation system being initially evaluated has such problems and they can be quantified.

If any MILs conducting an evaluation obtain unusually low EU or DU values of less than 50%, they will consult with their partner agencies prior to reporting the PWS associated with such values.

The PWS associated only with a change in irrigation schedule will be quantified and documented by the MILs as follows and as applicable: it shall be the difference in volume of water used on an annual basis, due to the potential reduction in irrigation system hours of operation. That reduction in hours of operation must be from a **documented and supported potential reduction on irrigation system irrigation event frequency, and/or irrigation system run time per irrigation event. The associated PWS volume **must** be quantified by the MIL as follows: multiplying the number of potential hours associated with the use reduction, by the **documented** flow rate (obtained via the MIL evaluation) of the irrigation system. **The use of verbal hear-say flow rate and/or hour reduction information to calculate this type of PWS is not acceptable. In that case, this PWS should be reported as zero.****

The PWS of an evaluation associated only with repairs of leaks, repairs of irrigation heads, and/or replacements of irrigation heads can only be quantified as applicable by using a valid method to determine the volume of water lost to leaks and/or disrepairs. **The MIL must use methods that physically measure those volumes on the field using flow meters or equivalent**

devices and not rely on “paper estimates” or hear-say; except for irrigation system emitters or heads where the official manufacturer design flow information can be used. This volume can be determined by using the **documented** flow rate of the leaks or disrepairs, and multiplying it by the **documented** number of hours the irrigation system is used on an annual basis. **If this cannot be done, then this PWS should be reported as zero.**

4.4 Calculating Actual Water Savings (AWS)

Actual Water Savings (AWS) is defined as the total amount of water saved on an annual basis, due to following any or all of the recommendations derived from irrigation system evaluation(s) by the MIL.

There are two instances when an MIL can quantify AWS:

- When the MIL is conducting a **follow up evaluation of the same irrigation system** it initially evaluated.
- When the **original irrigation system evaluated by the MIL has been completely replaced by a more efficient and new irrigation system.**

The AWS determined from a **follow up evaluation** of an irrigation system is defined as the portion of the PWS of that same irrigation system which has actually been saved due to implementation of some or all MIL recommendations, which is quantified via follow up evaluations. The PWS obtained from the one and only initial evaluation to that same irrigation system (see Section 4.2 above) shall always be used by the MIL as a reference for any AWS obtained from follow up evaluations.

The AWS determined from an **original irrigation system being completely replaced by a more efficient and new irrigation system** is the difference between the amount of water that the old irrigation system was using on an annual basis (per the **last** evaluation done by the MIL on that system), and the amount of water being used on an annual basis by the new irrigation system (per the **initial** evaluation done by the MIL on that system). Such AWS results shall be associated with the new irrigation system for purposes of reporting (not the old irrigation system), and shall be reported separately from the PWS of the new irrigation system.

For purposes of this Handbook, AWS will be divided into the following three defined categories:

AWS Due to Irrigation System Efficiency Improvements (ac-ft): The documented amount of irrigation water saved annually by improving the DU or EU of the irrigation system, which should lead to a reduction in hours of irrigation required.

AWS Due to Irrigation System Scheduling (ac-ft): The documented amount of irrigation water saved annually due to documented schedule changes (run time and frequency).

AWS Due to the Repair of Leaks and/or any Applicable Irrigation System Components (ac-ft): The documented amount of irrigation water saved annually from documented repairs of irrigation system leaks or components, or the documented replacement of faulty irrigation system components.

In order to calculate AWS, it is important to also define the following terms:

Net Irrigation Requirement (NIR, inches):

The minimum amount of irrigation water required/necessary for a plant or crop annually, based on the area of the State it is grown, and the **average or normal** climatic condition under which it is grown.

For land where more than one crop is grown during the season (crop rotation), the NIR is the summation of the NIR for each crop during that 12 month period and is referred to as the Annualized NIR.

The NIR for common crops grown in Florida under **average or normal** conditions can be found in the NRCS NEH, Part 652, Irrigation Guide, Florida Supplement, Chapter 4. This handbook can be found in the FOTG, Section I., C. References, 1. Engineering References, e. Part 652, Irrigation Guide – Florida Supplement, Chapter 15, at the following web address:
<http://efotg.sc.gov.usda.gov/treemenuFS.aspx>.

The Normal Year NIR is defined as:

Normal Year Crop water requirement (inches) – Normal Year Effective Rainfall (inches)

Actual Water Used (AWU, Inches):

The actual amount of water used annually for irrigation of a plant or crop, based on **documented** irrigation flowmeter and irrigation scheduling information provided by the farmer or obtained by the MIL. **Verbal hear-say information is not acceptable AWU.**

Only the AWS associated with **documented** irrigation system DU or EU efficiency improvements, **documented** irrigation management/schedules, and/or **documented** repair of leaks and/or irrigation system components will be quantified at this time. As mentioned previously in this chapter, as more methods to quantify other water conservation activities become available and are officially approved by the ICC and its partners, they will be added to the MIL-TH.

Calculating AWS Due to DU or EU Efficiency Improvements:

There are two methods by which AWS associated only with irrigation system DU or EU efficiency improvement can be calculated by the MIL, depending on the NIR or annual actual water use information available to the MIL at the time of the follow up evaluation. **Only one of these two methods shall be identified and used by the MIL.:**

For MILs Using NIR:

AWS, Efficiency, NIR _(ac-ft) :

$$= \left(\left(\left(\frac{NIR_{initial\ eval}}{DU\ or\ EU_{initial\ eval}} \right) \times \left(\frac{irrigated\ acres_{initial\ eval}}{12} \right) \right) - \left(\left(\frac{NIR_{follow-up\ eval}}{DU\ or\ EU_{follow-up\ eval}} \right) \times \left(\frac{irrigated\ acres_{follow-up\ eval}}{12} \right) \right) \right)$$

For MILs Using AWU:

AWS, Efficiency, AWU _(ac-ft) :

$$= \left(\left(\left(\frac{AWU_{initial\ eval}}{DU\ or\ EU_{initial\ eval}} \right) \times \left(\frac{irrigated\ acres_{initial\ eval}}{12} \right) \right) - \left(\left(\frac{AWU_{follow-up\ eval}}{DU\ or\ EU_{follow-up\ eval}} \right) \times \left(\frac{irrigated\ acres_{follow-up\ eval}}{12} \right) \right) \right)$$

Any follow up evaluation AWS calculated by an MIL using a follow up evaluation DU or EU that is higher than the Max DU or EU in Table 4, will still be valid and shall still be reported by the MIL to the ICC partner agencies using the approved standard reporting forms identified in the MIL Administrative Handbook.

There are instances where the DU or EU obtained from the follow up evaluation of a particular irrigation system may be too low and the AWS results using the two methods above will not be valid. If MILs conducting a follow up evaluation obtain EU or DU values that are less than 50%, they will consult with their partnering agencies prior to reporting the AWS values obtained from such evaluations.

Calculating AWS Associated with a Change in Irrigation Schedule:

The AWS associated only with a change in irrigation schedule will be quantified and **documented** by the MILs as applicable, and shall be the difference in volume of water used **on an annual basis**, due to the actual reduction in irrigation system hours of operation.

That reduction in hours of operation must be from a **documented and supported** reduction on irrigation system irrigation event frequency, and/or irrigation system run time per irrigation event.

The associated AWS volume **must** be quantified by the MIL as follows: multiplying the actual number of **documented** hours associated with the use reduction, by the **documented** flow rate (obtained via the MIL evaluation) of the irrigation system.

The use of verbal hear-say flow rate and/or hour reduction information to calculate this type of AWS is not acceptable and shall not be reported by the MIL to its partner agencies. In that case, this AWS shall be reported by the MIL as zero.

Calculating AWS Associated with Repairs or Parts Replacements:

The AWS of an evaluation associated only with repairs of leaks, repairs of irrigation heads, and/or replacements of irrigation heads can only be quantified as applicable, by using a valid method to determine the volume of water actually saved **on an annual basis.**

The MIL must use methods that physically measure those volumes on the field using flow meters or equivalent devices and not rely on “paper estimates” or hear-say; except for irrigation system emitters or heads where the official manufacturer design flow information can be used.

This volume can be determined by using the **documented** flow rate of the leaks or disrepairs, and multiplying it by the **documented** number of hours the irrigation system is used **on an annual basis.**

If this cannot be done, then this AWS shall be reported by the MIL to the partner agencies as zero.

4.5 Calculating Immediate Water Savings (IWS)

Immediate Water Savings (IWS) can be achieved if same day repairs are made per the MIL recommendations, or if irrigation schedule changes are made at the time of the evaluation or when the report is delivered.

Those water savings are typically quantified by comparing a water meter reading after repairs and/or adjustments are completed, against a water meter reading before the repairs and/or adjustments were completed. That difference in water meter readings shall be used by the MILs in combination with the annual irrigation schedule of the system, to come up with an annual volume of water saved.

Water savings resulting from repairs and/or adjustments (per the MIL evaluation and recommendations report) that do not occur on the same day of the evaluation need to be documented via future follow-up evaluations.

4.6 Reporting Water Conservation Results to Partner Agencies

All agricultural MILs are responsible for providing their contract and/or in-kind services partners (such as NRCS and FDACS) with the water savings results they obtained via their evaluations (initial and follow up). Urban MILs may or may not have the same requirements, depending on any contractual obligations they may or may not have with any partner agencies.

Evaluations reports may be subject to a technical Quality Assurance Review (QAR) by NRCS. Each MIL will ensure quality control (QC) measures are in place to ensure customers receive accurate and professional reports from MIL staff.

Appendix A of the MIL Administrative Handbook lists the reports the MILs are currently generating, to document such water savings results. They are:

1. Condensed Quarterly Report
2. Irrigation System Evaluations: Water Savings Data and Results
3. Irrigation System Water Source, Pumping Station and Other Information
4. Tracking Table for Initial Evaluations, Follow Up Evaluations, or Replacements
5. Conservation Education and Outreach
6. Evaluation Waiting List

All reports are required of all MILs except for the fifth report, which is only required of some MILs.

4.7 Typical Water Conservation Report to the Farmer or Client

MIL's develop for the irrigator or client a report of findings and recommendations required for the irrigation system to operate properly and efficiently. As a minimum, that water conservation report should include a cover letter, evaluation data, problems encountered, potential water savings or actual water savings, water quality analysis (if conducted), and recommendations.

The following sections contain typical water conservation reports for evaluations performed on both agricultural and urban irrigation systems.

4.7.1 Agricultural

4.7.1.1 Center Pivot Irrigation System Evaluation



January 23, 2017

I'm Thirsty Farms
Drytown, Florida

Dear Mr. Thirsty

Reference: The Dry Place Center Pivot Irrigation System

Thank you for allowing the XXX Mobile Irrigation Lab the opportunity to provide evaluation services for the above referenced irrigation system.

The XXX Mobile Irrigation Lab is one of many members of the XXX Partnership. The MIL is now into the Xth year of operation and has recently expanded services into XX counties. Our services remain free of any charge.

Many factors can influence the performance of the irrigation system. The MIL evaluation process is designed to test the overall ability of the system to evenly distribute water and measure the percentage of application loss. It is the desire of this MIL to represent the system in an unbiased report using USDA, Natural Resource Conservation Service (NRCS) guidelines as standards. Potential Water Savings (PWS) and Actual Water Savings (AWS) are calculated using Net Irrigation Requirements (NIR). Net Irrigation Requirements are defined as the amount of irrigation required to grow the crop, after consideration for estimated rainfall amounts. Crops on North Florida soils can be difficult to manage as significant rainfall or over applications of irrigation can quickly move nutrients below the root zone.

Thank you for your help in scheduling and assisting in the evaluation process. Should you have other systems that need testing or have questions or suggestions about our reporting format, please contact us.

XXX MIL

Enclosure

Recommendations: I'm Thirsty Farms / The Dry Place / January 23, 2016

The following recommendations will improve the Distribution Uniformity (DU) and Application Efficiency (AE) of this center pivot irrigation system. *The DU% is a score given after an MIL evaluation that indicates how evenly irrigation water is distributed across your field. The DU score is important because the lower the score the more uneven irrigation water is applied and this can affect your crop's health and production. The Application Efficiency (AE) % expressed here is a measure of the amount of water pumped versus the amount of water that actually reaches the crop canopy. These losses occur through evaporation, drift and/or leaks. Any changes made to the irrigation system should be re-evaluated as it will change the Application Chart and uniformity pattern.*

- 1) The End Gun application represents a large percentage of the field. The Distribution Uniformity (DU) % reported here includes the End Gun application within the overall score.
- 2) As noted at the bottom of page one, the End Gun should be adjusted to the recommended rotation. This rotation change will likely correct the application rate and could improve DU%.
- 3) Any retrofit to an upgraded nozzle package must be matched to the known, gallons per minute (GPM) flow rate of the well/pump and system operating pressure at the pivot.
- 4) Page (4) is the customized Application Chart which is an irrigation management tool. The application amount indicated in the highlighted column is what you can expect after efficiency losses are considered and the hours per revolution at the chosen timer setting.
- 5) As indicated by the enclosed uniformity graph, pressure regulators are failing.
 - a) Manufacturers suggest 2 to 4 years of good service can be expected from pressure regulators.
 - b) Failing pressure regulators can result in heavy irrigation application in certain areas of the field while depriving other areas of the field. Review the enclosed graph and note the areas by the tower locations that have contrasting application rates. The crop may be suffering from a low water application in some areas or nitrogen may be leaching quickly past the root zone due to a high application rate in others. In either case crop grade and yield may suffer.
 - c) It is NOT recommended to replace only a few pressure regulators but to consider a complete, matched nozzle and pressure regulator retrofit package.
- 6) The following nozzles are plugged or are not working.
 - a) Span# 2 Nozzle# 4
 - b) Span# 4 Nozzle# 12
- 7) Towers are out of alignment.
 - a) Consult your irrigation vendor to troubleshoot the cause of misalignment.
- 8) Missing guard for PTO shaft.
 - a) To practice safety, it is a good idea to place a shield over all exposed PTO shafts.
- 9) Broken pressure gauge.

- a) The pressure gauge takes the pulse of the irrigation system. For proper irrigation management it is important to maintain the system designed pressure.
 - b) Consider maintaining working pressure gauges at the beginning and end of the system to verify working pressure.
- 10) Standing water in the field.
- a) There are drainage problems in certain areas of the field, application rates should be considered over these areas.
- 11) Soil compaction was measured with a penetrometer.
- a) In this case the hardpan was measured at xxx inches.
 - b) Soil compaction can prevent crop roots from reaching available moisture.
- 12) Because of obstructions in the field the pivot could not make a complete circle, however the Timer Chart enclosed here considers the partial circle on next page.
- 13) Plugging the first nozzle will lower high application near the pivot point.

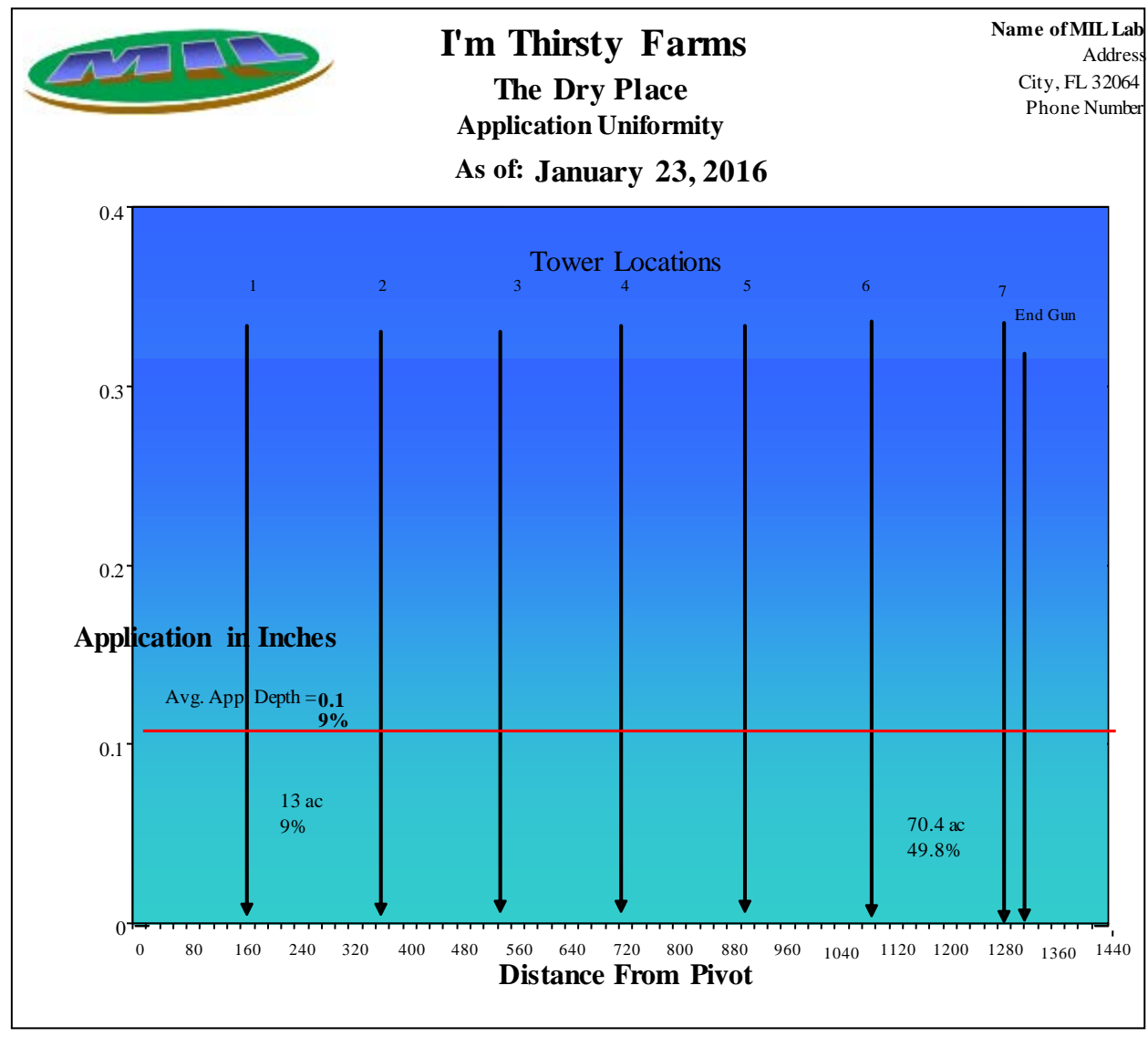

Distribution Uniformity 66%

Distribution Uniformity without End Gun 65%

General Info	Date of Eval / Pre / Post / %	January 23, 2015	pre	0
	System Model / Nozzle Type	Valley / 6000 / Diesel	Valley / Sprays / On drops	
	Wetted Length (ft) / Acres est. / GPS meas. ac	1400	141	0
	Temperature / Wind / Weather	72		
	Timer Setting (%) / Rotation (%)	70	78%	

System Output	System Flow @ Pivot Point (GPM)	900		
	System Pressure (psi) / Engine RPM	24	1800	
	Total System Output (in) / Effective Irrigation	0.22	0.19	
	Loss to Evaporation, Drift and Leaks	0.03	14.50%	
	Application Efficiency	86%		

Operating Cost	7 GPH @ \$2.50 & 0 0 \$0.00	\$17.50	Estimated cost Per Hr	
	Loss to Evaporation, Drift and Leaks	\$2.54	14.50%	
	Loss to Displaced Water Dist DU 95%	\$5.06	28.90%	
	Total \$ Losses /Hr	\$7.59	43.40%	

Savings	Potential Water Savings (million gal. / crop)	12.91		
	Potential Reduced Pumping Hrs. (per crop)	239.1		
	Potential Savings (via reduced per crop)	\$4,184		
	Actual Water Savings (million gal. per crop)	NA		

Present End Gun Rotation

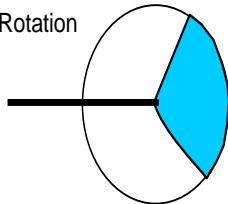

Recommended End Gun Rotation

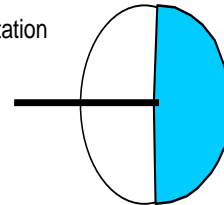

Distribution Uniformity (DU%) measured here is expressed as the percent ratio of the average depth of the low quarter of the catches to the overall average: $DU = LQ/M$, where: LQ = average of the lowest 1/4 of the irrigation amounts; M = average of all irrigation amounts. Potential Water Savings, Reduced Pumping Hours, and Potential Savings are based on Mobile Irrigation Lab Standards, and USDA / NRCS Irrigation Standards for crop water use. Actual Water Savings are based on the Post DU%.

Date of Eval:

January 23, 2016

Application Chart

Percent Timer Setting	Hours Per Revolution @ Rotation	Avg. Inches per Rotation (Potential)	Avg. In. @ 5% Loss (Overcast)	Avg. In. @ 10% Loss (Sunny, Calm)	Avg. In. @ 15% Loss (Sunny, Windy)
100	11.11	0.16	0.15	0.14	0.13
95	11.69	0.17	0.16	0.15	0.14
90	12.34	0.17	0.17	0.16	0.15
85	13.07	0.18	0.18	0.17	0.16
80	13.88	0.20	0.19	0.18	0.17
75	14.81	0.21	0.20	0.19	0.18
70	15.87	0.22	0.21	0.20	0.19
65	17.09	0.24	0.23	0.22	0.21
60	18.51	0.26	0.25	0.24	0.22
55	20.19	0.29	0.27	0.26	0.24
50	22.21	0.31	0.30	0.28	0.27
45	24.68	0.35	0.33	0.31	0.30
40	27.77	0.39	0.37	0.35	0.33
35	31.73	0.45	0.43	0.40	0.38
30	37.02	0.52	0.50	0.47	0.45
25	44.43	0.63	0.60	0.57	0.53
20	55.54	0.79	0.75	0.71	0.67
15	74.05	1.05	1.00	0.94	0.89
10	111.07	1.57	1.49	1.41	1.34
5	222.14	3.14	2.99	2.83	2.67
1	1110.70	15.71	14.93	14.14	13.36

Percentages of loss according to weather conditions is determined by current and actual conditions as measured by the Mobile Irrigation Lab in numerous irrigation system evaluations. However due to the unpredictability of the changing weather conditions, these losses are only a guide for your scheduling. Irrigation during the night time hours will be the most efficient.

4.7.1.2 Microirrigation System Evaluation

IRRIGATION SYSTEM EVALUATION REPORT

AND

IRRIGATION WATER MANAGEMENT PLAN

Hurry I. Dry Grove
Need Water Rd

Manatee County, FL

January 23, 2017

Prepared by:
NRCS Mobile Irrigation Lab

USDA/NRCS
State Office
2614 NW 43rd Street
Gainesville, FL 33873
Tel. 352-338-9562



Irrigation System Evaluation Report

January 23, 2017

Hurry I. Dry
Ducite, FL

Dear Mr. Dry:

Thank you very much for your interest in water conservation. The results of the evaluation of the irrigation systems at the Need Water Road grove in Manatee County, FL are enclosed.

This report includes an Irrigation Water Management (IWM) Plan, a list of problems found during the evaluation, and improvement recommendations. The IWM Plan includes an irrigation scheduling guide for each grove. The scheduling guides indicate the duration and frequency of irrigation, and delay days after rainfall. These guides were developed based on current field and system conditions specific to this site and are the first step toward Irrigation Water Management (IWM). Adjustments to these guides will be necessary as you evaluate your crop's response to irrigation. A new scheduling guide should be created any time changes are made to the irrigation system.

The Natural Resources Conservation Service (NRCS) recommend the use of soil moisture sensors such as tensiometers as a valuable tool to improve your irrigation water management. Please let us know if you need assistance in the use of these devices.

Call the NRCS Mobile Irrigation Lab at 352-338-9562 for questions about this report or other irrigation water management issues.

Sincerely,

Eric Gator
Agricultural Engineer
NRCS Mobile Irrigation Lab

Hurry I. Grove
Need Water Rd
Manatee County, FL

EMISSION UNIFORMITY (EU)

Grove	Evaluation Date	System Pressure	EU
Need Water Rd Grove	January 23, 2017	21 psi	86 %

Problems and Recommendations

Clogged Emitters - Many emitters were clogged, especially at the ends of the lateral lines. Clogging can be reduced by flushing the laterals more often, using self-flushing end caps, or in severe cases, injecting chlorine, with the injection program based on sulfide and iron concentrations.

Mixed Emitters - Emitters with differing discharge rates are being used. The system design should be reviewed to determine the correct discharge rate and number of emitters to use. Using the correct emitter is necessary to allow good pressure and flow distribution for a particular pipe design. One model of emitter should be used throughout the system, since different models and makes could have different flow rates.

Broken Pipes and Leaks - Cuts and breaks were found in the lateral lines. Even small leaks can significantly reduce pressure in downstream sections. Repairing breaks will improve discharge uniformity and increase overall pressure.

Bad Filter Gauges - The pressure gauges before and after the filter are not working and should be replaced. These gauges provide an indication of the system pressure and the condition of the filter. A drop of more than 5 psi across the filter is an indication that the filter is clogged and should be flushed and/or cleaned.

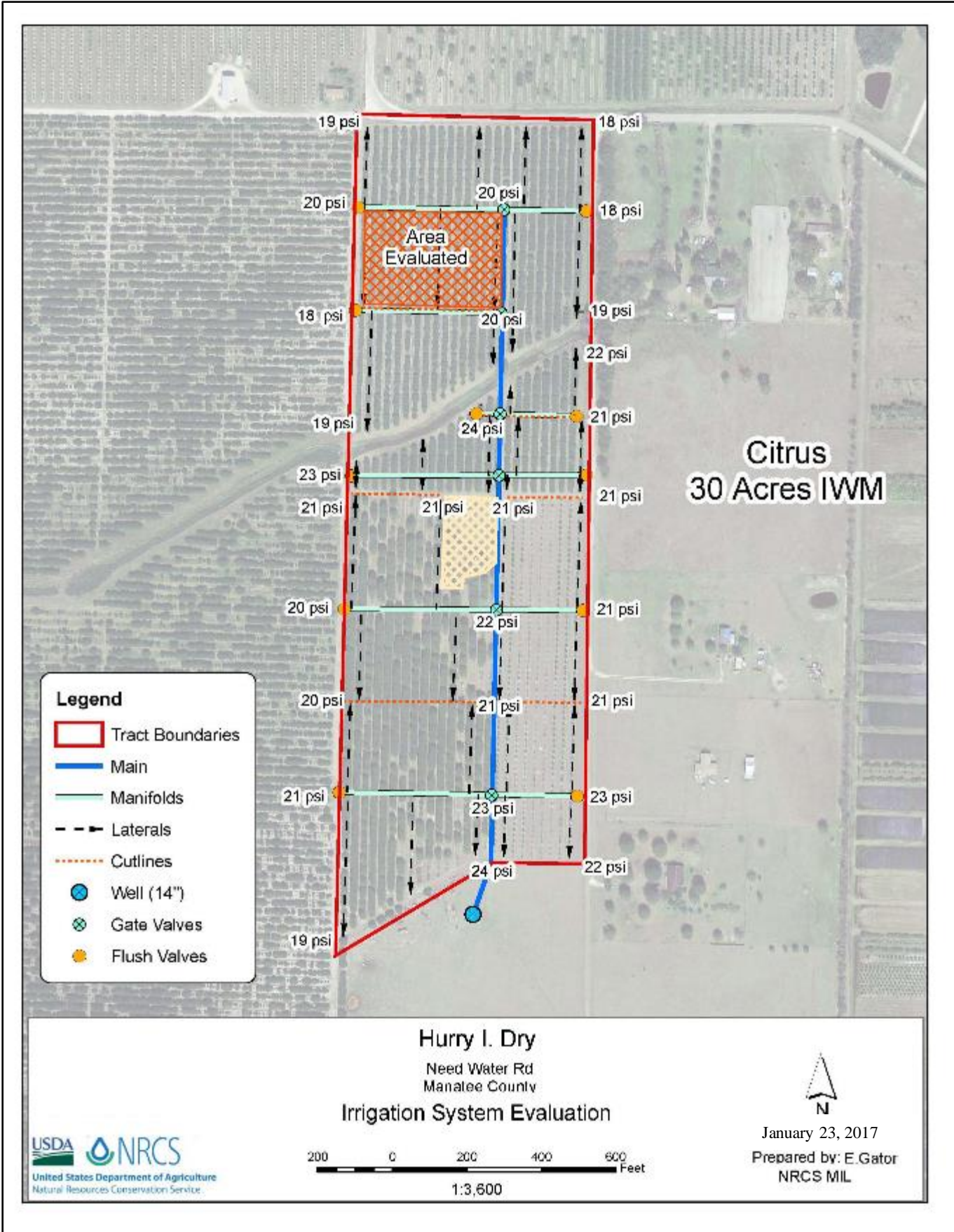

Hurry I. Dry Grove
Need Water Rd, Manatee County
January 23, 2017



Hurry I. Dry Grove
Need Water Rd, Manatee County

January 23, 2017





NRCS Mobile Irrigation Lab (MIL)
 2614 NW 43rd Street
 Gainesville, FL 32606
 (352) 338-9500

MICROIRRIGATION EVALUATION Ver 1.2

IDENTIFICATION

Farmer/Operator:	Hurry I. Dry	Technicians:	Erie Gator
Address:	Need Water Road	Date:	1/6/2015
	Home Grove	Evaluation Date:	1/6/2015
Phone:		Field Office:	Sarasota
County:	Manatee	Field ID:	Home
Field Area (acres):	30.00	Field No:	All
Filename:			

SYSTEM INVENTORY

SYSTEM			
Type (Drip, Spray or Line Source):	Spray	Age (years):	5+
EMITTER			
Type:	Yellow	Make:	Maxijets
Model:	14-Stream	Pressure Compensating (Y or N):	N
Design Pressure (psi):	20.0	Design Discharge (gph):	19.80
Number of Emitters per plant:	1.0	Spacing (ft):	10.0
		Discharge Exponent (Blank=unk.):	
SYSTEM DATA			
Pump rpm	1600.0	Capacity (gpm):	?
Flow Meter? (Y or N):	N	Number of Zones:	1
LATERAL (TUBING)			
Number of laterals/row:	1	Length (ft):	
		Inside Diameter (in):	1.049
CHEMIGATION			
Fertilizer? (Y or N)	Y	Chlorine or Acid? (Y or N):	Y
FILTERS			
Sand Media? (Y or N)	N	Screen? (Y or N):	Y
Centrifugal Separator? (Y or N):	N	Automatic flushing? (Y or N):	N
PRESSURE REGULATED			
Automatic at head? (Y or N):	N	Manual Throttle at Head? (Y or N):	Y
At entrance to manifolds? (Y or N):	N	At Entrance to Laterals? (Y or N):	Y
CROP			
Type:	Citrus	Transpiration Ratio (1 to 1.1):	1.11
Row spacing (ft):	25.00	Plant Spacing (ft):	10.0
Canopy Dimensions (ft):	Diameter 16.00	Age (years)	5+
	Length	(months)	
	Width	Root Depth (in):	18.0
Peak Water Requirement (in/day):	0.19	Annual Irrigation Required (in/yr):	15.83
SOIL			
Series:	45-Tavares	Texture:	FS
Water Holding Capacity (in/in):	0.040		
IRRIGATION OPERATION			
Peak Irrigation Duration (hrs):	4.00	Frequency (whole days):	5.0
MAD (Management Allowed Deficit) (%):	50%		
WATER SOURCE -(well or surface):			
	Well	PUMP TYPE:	Turbine



Farm Irrigation Rating Index - Florida (FIRI - FL) Version 1.0

Cooperator:	Hurry I. Dry	Farm Name:	Home Grove
Location:	Need Water Road	Field ID:	
Conservation District:		Field Office:	Manasota
Water Management District:	Southwest Florida Water Management District	County:	Manatee
Irigated Crop:	Citrus	Irigated Area, acres:	30.0
	Net Irrigation Requirement, inches:		15.8

Category	Present Condition	Planned Condition
Irrigation System Type	Microirrigation-sprays 0.85	Microirrigation-sprays 0.85

Management Factors

Category	Action	Rating	Action	Rating
Improved Water Measurement	No flow measuring devices	0.90	Flow measurement-whole farm plus individual field automatically recorded	1.00
Improved Soil Moisture Monitoring and Irrigation Scheduling	Irrigation scheduling via regional weather network	0.97	Continuous measurement of soil moisture, water applied, and evapotranspiration (ET)	1.00
Irrigation Skill and Action	Good-lack of full attention	0.92	Following irrigation water management (IMM) plan	1.00
Maintenance Factor	Good	0.98	Excellent	1.00
Water Delivery	Demand-unrestricted rate	1.00	Demand-unrestricted rate	1.00
Improved Soil Condition Index	Soil Condition Index = 0.8	0.99	Soil Condition Index = 0.8	0.99

System Factors

Category	Action	Rating	Action	Rating
Improved Distribution System	Can control flow rates to farm, but the on-farm delivery system is such that it is very hard to deliver the desired flow to any given field	0.94	All flow rates to each set are adequately controlled	1.00
Improved Conveyance System	Material	Length (ft)	Material	Length (ft)
	Closed conduit pipeline	1.00	Closed conduit pipeline	1.00
Improved Land Leveling	Asprinkler or microirrigation system is used	1.00	Asprinkler or microirrigation system is used	1.00
Adding Tailwater Recovery With and Without Irrigation Storage Reservoirs	0%	1.00	0%	1.00
Climatic Factor	Hot-peak average evapotranspiration (ET) of 0.60	0.95	Hot-peak average evapotranspiration (ET) of 0.60	0.95
Wind Factor	Non-spray Low Energy Precision Application (LEPA) or point source microirrigation	1.00	Non-spray Low Energy Precision Application (LEPA) or point source microirrigation	1.00
Sprinkler Factor	Microirrigation system	1.00	Microirrigation system	1.00
Emitter Clogging Factor	Spray-Treatment: none; Flushing: none; Temperature: 149F; Sum of clogging: > 20%	0.96	Spray-Treatment: none; Flushing: none; Temperature: 149F; Sum of clogging: > 20%	0.96
Drip-Micro Design Factor	Average coefficient of variability (Cv)-flow variability +/- 15%	0.95	Excellent coefficient of variability (Cv)-flow variability +/- 5%	1.00

FIRI Rating: Present Condition = 70.8 Planned Condition = 79.5

Change in FIRI Rating	8.7
Water Conserved per acre	0.2
Water Conserved (gallons)	1,993,669
Water Conserved (acre-feet)	6.1
Water Conserved (acre-inch)	73.4
Water Conserved	11%

Comments:

Prepared by: _____ Date: _____
 Checked by: _____ Date: _____

Available Water Capacity—Manatee County, Florida
(Hurry 1, Dry)

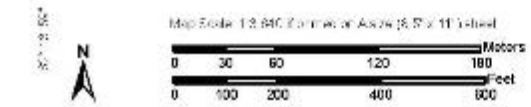
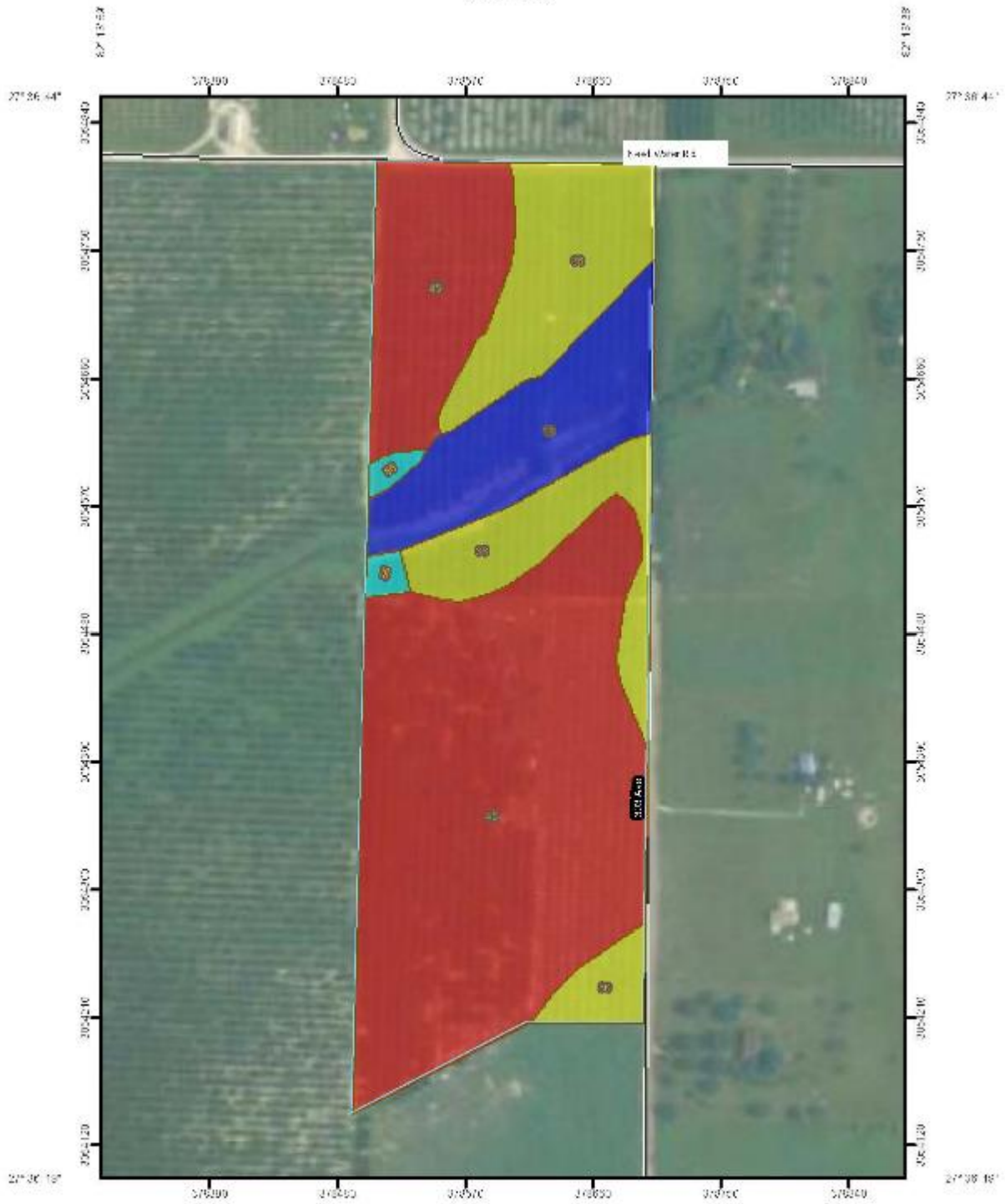

USDA Natural Resources Conservation Service

Web Soil Survey National Cooperative Soil Survey

8/31/2009 Page 1 of 4

Available Water Capacity

Available Water Capacity— Summary by Map Unit — Manatee County, Florida				
Map unit symbol	Map unit name	Rating (centimeters per centimeter)	Acres in AOI	Percent of AOI
18	Delray-Pomona complex	0.12	4.0	12.6%
36	Orlando fine sand, moderately wet, 0 to 2 percent slopes	0.06	6.9	22.2%
45	Tevares fine sand, 0 to 5 percent slopes	0.04	19.7	63.7%
55	Zolfo fine sand, 2 to 5 percent slopes	0.07	0.4	1.2%
Totals for Area of Interest			30.9	100.0%

Description

Available water capacity (AWC) refers to the quantity of water that the soil is capable of storing for use by plants. The capacity for water storage is given in centimeters of water per centimeter of soil for each soil layer. The capacity varies, depending on soil properties that affect retention of water. The most important properties are the content of organic matter, soil texture, bulk density, and soil structure, with corrections for salinity and rock fragments. Available water capacity is an important factor in the choice of plants or crops to be grown and in the design and management of irrigation systems. It is not an estimate of the quantity of water actually available to plants at any given time.

Available water supply (AWS) is computed as AWC times the thickness of the soil. For example, if AWC is 0.15 cm/cm, the available water supply for 25 centimeters of soil would be 0.15 x 25, or 3.75 centimeters of water.

For each soil layer, AWC is recorded as three separate values in the database. A low value and a high value indicate the range of this attribute for the soil component. A "representative" value indicates the expected value of this attribute for the component. For this soil property, only the representative value is used.

Rating Options

Units of Measure: centimeters per centimeter

Aggregation Method: Dominant Component

Component Percent Cutoff: None Specified

Tie-break Rule: Higher

Interpret Nulls as Zero: No

Layer Options: Depth Range

Top Depth: 0

Bottom Depth: 18

Available Water Capacity--Manatee County, Florida
(Hurry I. Dry)

MAP LEGEND

- Area of Interest (AOI)**
 Area of Interest (AOI)
- Soils**
 Soil Map Units
- Soil Ratings**
-  ≤ 0.04
 -  > 0.04 AND ≤ 0.06
 -  > 0.06 AND ≤ 0.07
 -  > 0.07 AND ≤ 0.12
 -  Not rated or not available
- Political Features**
 Cities
- Water Features**
 Oceans
 Streams and Canals
- Transportation**
 Rails
 Interstate Highways
 US Routes
 Major Roads
 Local Roads

MAP INFORMATION

Map Scale: 1:3,640 (if printed on A size (8.5" x 11") sheet).

The soil surveys that comprise your AOI were mapped at 1:24,000.

Please rely on the bar scale on each map sheet for accurate map measurements.

Source of Map: Natural Resources Conservation Service
Web Soil Survey URL: <http://websoilsurvey.nrcs.usda.gov>
Coordinate System: UTM Zone 17N NAD83

This product is generated from the USDA-NRCS certified data as of the version date(s) listed below.

Soil Survey Area: Manatee County, Florida
Survey Area Data: Version 6, Oct 5, 2006

Date(s) aerial images were photographed: 8/6/2007

The orthophoto or other base map on which the soil lines were compiled and digitized probably differs from the background imagery displayed on these maps. As a result, some minor shifting of map unit boundaries may be evident.

Hurry I. Dry Grove - Need Water Rd

System Information

Crop	Citrus	Peak Water Requirement	0.19 in/day
Soil	Tavares	Wetted Diameter (Area)	16 ft (201 ft ²)
Water Source	16" Well	Canopy Diameter (Area)	16 ft (201 ft ²)
Pump rpm	1600	Emitters per Tree	1
Filter	Screen	Emitter Type	Maxi - Yellow (Mix)
Zones	1	Net Average Discharge	15.64 gph
Total Acres	30	Spacing (Row x Trees)	25 ft x 10 ft
Trees Age	5 yrs +	Root Depth	18 in
System Pressure	21	Water Holding Capacity	0.04 in/in

Irrigation Scheduling Guide

	Irrigation			Rainfall	
	Management Allowed Deficit	Operating Time*	Interval	Delay per 1/4 inch rainfall	Maximum Delay
Month	(%)	(Hrs:Min)	(Days)	(Days)	(Days)
January	30	1:45	4	4	4
February	30	1:45	3	4	3
March	30	1:45	3	3	3
April	30	1:45	2	2	2
May	30	1:45	2	2	2
June	30	1:45	1	2	1
July	50	3:00	2	2	2
August	50	3:00	2	2	2
September	50	3:00	3	2	3
October	50	3:00	4	2	3
November	50	3:00	5	3	5
December	50	3:00	6	4	6

* Operating time rounded to the nearest 15 minutes.



NRCS Mobile Irrigation Lab
 2614 NW 43rd Street
 Gainesville, FL 32606
 Tel: 352-338-9562

Irrigation Water Management Plan

Cooperator: Hurry I. Dry **Date:** October 1, 2009
Location: Need Water Rd **Prepared by:** Erie Gator
County: Manatee **Title:** Agricultural Engineer

Irrigation water management (IWM) is the process of determining and controlling the volume, frequency, and application rate of irrigation water in a planned and efficient manner. The objective is to maintain soil moisture at levels conducive to optimal plant growth and maximize irrigation efficiency. The most important aspect of IWM is to monitor the crop and soil moisture relationship. This can better be accomplished by the use of soil moisture sensors such as tensiometers.

This IWM plan describes the techniques and strategies you will use to determine when and how much to irrigate. Changes in the system would affect the recommended operating times. If changes are made to the irrigation system, a new evaluation should be made. If you would like to change or correct this IWM Plan, please let us know by calling your NRCS Service Center.

Irrigation system type	Uniformity of water application will be determined by
<input checked="" type="checkbox"/> Sprayjets	<input checked="" type="checkbox"/> System evaluation
<input type="checkbox"/> Sprinkler	<input checked="" type="checkbox"/> Observation of water distribution
<input type="checkbox"/> Drip	<input checked="" type="checkbox"/> Observation of wetted area
<input type="checkbox"/> Subsurface	<input checked="" type="checkbox"/> Periodic pressure measurement
Water Source	Runoff caused by irrigation will be estimated by
<input checked="" type="checkbox"/> 14" Well	<input type="checkbox"/> Measurement of stream size
<input type="checkbox"/> Surface	<input type="checkbox"/> Observation
<input type="checkbox"/> Other	<input checked="" type="checkbox"/> Does not occur
Method used to determine when to irrigate	Method used to determine quantity of water needed
<input checked="" type="checkbox"/> Tensiometers	<input checked="" type="checkbox"/> Tensiometers
<input type="checkbox"/> Evaporation pan	<input checked="" type="checkbox"/> Soil feel and appearance
<input checked="" type="checkbox"/> Soil feel and appearance	<input checked="" type="checkbox"/> Leaf wilt
<input checked="" type="checkbox"/> Leaf wilt	<input checked="" type="checkbox"/> Scheduling guide
<input checked="" type="checkbox"/> Scheduling guide	<input type="checkbox"/> Water table depth
<input checked="" type="checkbox"/> Rainfall	<input checked="" type="checkbox"/> Rainfall
Application rate will be determined by	Soil erosion caused by irrigation will be estimated by
<input checked="" type="checkbox"/> System evaluation	<input type="checkbox"/> Measurement
<input checked="" type="checkbox"/> Emitter or sprinkler specs	<input type="checkbox"/> Observation
<input type="checkbox"/> Flowmeter	<input type="checkbox"/> Calculation
<input checked="" type="checkbox"/> Manifold Pressure	<input checked="" type="checkbox"/> Does not occur

Method Used to Determine When to Irrigate

The need for irrigation will be determined by the use of tensiometers, weather conditions, leaf wilt, and feel and appearance method. The Irrigation Scheduling Guide provided for each zone indicates the duration and frequency of irrigation, and delay days after rainfall.

The Irrigation Guides were developed based on field and system conditions specific for the site and are the first step toward Irrigation Water Management (IWM). Adjustments to these guides will be necessary as you evaluate your crop's response to irrigation.

During the bloom and fruit set period irrigation is applied when the six-inch tensiometers reach 15 centibars (cb). During the remainder of the year irrigation is applied at 20 cb.

The operating time can also be modified by the use of tensiometers that reach the bottom of the root system. For citrus, 18-inch tensiometers are suitable for this use. Operating time can be decreased if the 18-inch tensiometers drop below 10 cb and increased if readings rise above 15 cb during the bloom and fruit set period. During the rest of the year, operating time can be decreased if the 18-inch tensiometers drop below 10 cb and increased if they rise above 20 cb. These are general guidelines that may vary by soil type.

Method Used to Determine Quantity of Water Needed

The approximate number of hours to operate the system for water to reach the depth of the root zone is shown on the irrigation guide and on the above table. The schedule will be modified based on tensiometer readings, observations of the soil, and weather conditions. If it is necessary to follow a set schedule for the days to irrigate, for example, two times per week, then the duration of the irrigation is adjusted based on the observations of leaf wilt and soil moisture at the next scheduled irrigation time.

These are estimates that are to be confirmed or modified, based on observations of soil and weather conditions.

Climatic Data

Local climatic data was used to develop the scheduling guide. Modifications to the scheduling guide could be made by tracking current weather conditions. Additional and current weather information related to agricultural operations could be obtained at the Florida Automated Weather Network (FAWN) website at:

<http://fawn.ifas.ufl.edu/>

Application Rate and Uniformity of Application

Individual sprayjet flow measurements will be conducted periodically to ensure proper application rate. The application rate could also be verified by the use of a flowmeter for a zone. The number of emitters within a zone should deliver a consistent volume within a period of time.

System pressure and emitter wetted pattern will be monitored to ensure current application rate. Manifold pressure should be checked occasionally for proper sprayjet operation at or near the 20 psi range. Frequent pressure checks and the use of pressure gauges in key places of your system (e.g. pump and filters) will help recognize and solve problems. A pressure drop of 5 psi or more across the filter indicates that the filter is clogged.

Checking for leaks and observing the diameter and uniformity of coverage of the spray patterns will help maintain system performance. Cleaning clogged emitters and replacing broken emitters with emitters of the same type will maintain system uniformity.

Follow the Operation and Maintenance (O&M) provided with your Conservation Plan folder to ensure your system is operating properly.

	Need Water Rd Grove
Crop	Citrus
Net Irrigation Requirement	15.83 in/yr
System Emission Uniformity (EU)	86%
Potential Application Efficiency (= EU x 0.9)	77%
Present Operating Pressure	21 psi
Soil Type	Tavares FS
Soil Water Holding Capacity	0.04 in/in
Root Zone Depth	18"
Water Content at Field Capacity	0.72" (90 Gal)
Wetted Diameter (Area)	16' (201 ft ²)
Canopy Diameter (Area)	16' (201 ft ²)
Emitter Type	Maxijet - Yellow 360
Net Average Emitter Discharge	15.64 gph
30 % Depletion	0.22" (27 Gal)
Operating Time to Replace 30 %	1 Hr - 45 mins
50 % Depletion	0.36" (45 Gal)
Operating Time to Replace 50 %	3 Hrs

Runoff and Soil Erosion

By maintaining vegetative cover and accurate irrigation scheduling, runoff and erosion will be kept to a minimum. Flush valve areas will be monitored to prevent soil erosion.

Operation and Maintenance

Frequent maintenance is essential to keep emitters functioning at design flow. Typical maintenance items include but are not limited to:

- Flush lateral lines at least annually.
- Check applicator discharge often. Cleaning clogged emitters and replacing broken emitters with the same type will maintain system uniformity.
- Frequent pressure checks and the use of pressure gauges in key places of your system (e.g. pump and filters) will help recognize and solve problems. A pressure drop of 5 psi or more across the filter indicates that the filter is clogged.
- Check pressure gauges to ensure proper operation; repair/replace damaged gauges.
- Inject chemicals as required to prevent precipitate buildup and algae growth.
- Check and assure proper operation of backflow protection devices.
- Check emitter integrity often to ensure proper performance. Emitter stake should be straight and weeds should be control to maintain good wetted area and pattern.
- Perform all operations in a safe manner and in accordance with all applicable safety regulations.

4.7.2 Urban

4.7.2.1 Urban Irrigation System Evaluation

Name of SWCD
Mobile Irrigation Laboratory
Address
Phone Number

January 23, 2017

Landowner Name
Address

Dear Mr. Landowner:

Thank you for participating in the MOBILE IRRIGATION LABORATORY EVALUATION PROGRAM. This program is designed to evaluate how well your irrigation system is operating and to offer guidance on managing the system. Our goal is to assist in determining the proper amount of water required by the landscape while, at the same time, conserving water.

This program is operated by the XXX SOIL and WATER CONSERVATION DISTRICT in cooperation with the NATURAL RESOURCES CONSERVATION SERVICE. This project is funded by the SOUTH FLORIDA WATER MANAGEMENT DISTRICT and FLORIDA DEPARTMENT OF AGRICULTURE AND CONSUMER SERVICES.

Field observations were made to determine the uniformity and efficiency of the irrigation system. These observations allow us to make recommendations that should enhance the landscape and conserve water. The estimated efficiency of your system was 65%. By improving the uniformity of the system it can be run for less time and therefore use less water and money. Please review the following pages of information and recommendations on your sprinkler system.

If you need additional information, please contact me at XXX-XXXX.

Sincerely,

Your Name

M.I.L. Coordinator

IRRIGATION SYSTEM INFORMATION

Fully automatic - Your irrigation system is fully automatic. The controller selects the number of days between irrigations, time to start the irrigation for each zone, and the amount of time to irrigate each zone.

In order to conserve water and maintain a healthy landscape, adjustments to the controller are required. These adjustments include:

- 1) Changing the number of days between irrigations as the seasons (and water needs) change.
- 2) Adjusting the number of days between irrigations when there is rainfall between irrigations.

Your **Rain Sensor**, which can automatically delay the start of the system based on rainfall, is set too low. The sensor will prevent the system from watering during the rain or too soon after the rain without any manual adjustments to the controller. For best results the mounting location, the shut-off setting, and the vent setting are all important. Mount the rain sensor in a location that will receive direct rainfall and sunlight, will not receive water from the sprinkler system, and is not close to the air conditioner's exhaust fan. A shut-off setting of 0.5 inches will shut the system down as soon as the lawn has received sufficient rainfall. Keeping both of the bottom vents closed will prevent the system from coming on too soon after the rainfall.

The distribution uniformity (D.U.) is a measure of how evenly the water is applied over the area being irrigated. A well designed irrigation system under optimum conditions will have a D.U. of 85%. As the D.U. decreases, the efficiency of the system decreases since some of the plants or turf areas will receive insufficient water and others will be over watered. Recommended values of D.U. are a function of the value of the plants being grown (See table below).

Type of Vegetation Recommended	D.U.
High value plants (ornamental, greens) with little supplemental rainfall.	DU > 80%
Typical. (Lawn)	70% - 80%
Deep rooted plants (trees, deep rooted grasses) where supplemental rainfall is substantial.	55% - 70%

The estimated efficiency of your system was 65%. With some adjustments the system could be operating with an efficiency of 75%. Once the system adjustments and schedule adjustments are made, the water savings could be 94,074 gallons per year. You have immediate water saving of 133,681 gallons from changes to your zone run times on your controller. Irrigation time can be reduced by increasing the uniformity. Please see our recommendations listed below.

OUR RECOMMENDATIONS ARE:

Please note: The recommendations given below should help to improve the uniformity of your system. In some cases, the changes that are recommended will increase or decrease the output of a zone. These kinds of changes may adversely affect your system. If you are unsure, please contact a licensed irrigation contractor. For a list of licensed irrigation contractors in your area, you can contact the Florida Irrigation Society at 1-800-441-5341.

PLANTS

Plants recommended for Southwest Florida landscapes are considered "natural" by the SFWMD plant guide. This means that once established, they will survive on natural rainfall alone. Significant reductions in water consumption will occur if entire zones are landscaped with natural shrubs and ground covers. These zones can then be skipped during most irrigation cycles.

Zone 1

(Front landscaping and front left lawn)

Obstructed sprinklers - Some of the sprinklers were blocked or covered by turf, blocked by plants, and/or blocked by other items. Clearing around, raising up, or moving the sprinkler heads will help the obstructed sprinklers.

Excessive water overflow - A significant amount of irrigation water is being applied into your landscaping areas between the sidewalk and house. The sprinklers should be adjusted to prevent wasting water.

Plant beds with lawn area - Plant beds generally require less water than lawn areas. Separate irrigation zones should be used for optimum watering efficiency. With established plantings it may be possible to turn off or cap the sprinklers in the plant beds because these plants can survive on natural rainfall.

Four steps to improve the watering efficiency of this zone:

- 1) I recommend closing the front (SST) nozzle by the Liriope grass in the front landscaping area.
- 2) I recommend raising some of the lawn pop-up spray heads so they can pop up through the grass and water evenly.
- 3) I recommend a 20 minute run time for this zone.
- 4) This zone was set at 30 minutes from 60 minutes for an immediate savings of 35,444 gallons per year.

Zone 2

(Right side back spray heads)

Obstructed sprinklers - Some of the sprinklers were blocked or covered by turf, blocked by plants, and/or blocked by other items. Clearing around, raising up, or moving the sprinkler heads will help the obstructed sprinklers.

Plant beds with lawn area - Plant beds generally require less water than lawn areas. Separate irrigation zones should be used for optimum watering efficiency. With established plantings it may be possible to turn off or cap the sprinklers in the plant beds because these plants can survive on natural rainfall.

Four steps to improve the watering efficiency of this zone:

- 1) I recommend raising a few pop up spray heads so they pop up through the grass.
- 2) I recommend a 20 minute run time for this zone.
- 3) This zone was set at 30 minutes from 60 minutes with an immediate water savings of 34,472 gallons per year.
- 4) I recommend as you replace broken sprinklers to stay with the same type and same manufacture.

Zone 3

(Front lawn left of driveway)

Excessive pavement water overflow - A significant amount of irrigation water is being applied onto the driveway and street. The wetting pattern of the sprinklers should be adjusted to prevent wasting water. Reducing the watering distance and reducing or changing the wetting patterns will reduce the pavement overflow.

Sprinkler precipitation is not matched - Sprinklers in the same zone with different watering patterns (i.e. full, half, and quarter circle patterns) need to have their nozzle sizes adjusted. One of the most common causes of low uniformity is due to mismatched sprinklers nozzles in an irrigation unit. For example, if a zone has a full circle sprinkler with a four gallon per minute nozzle then any half circle sprinklers should have a two gallon per minute nozzle, and any quarter circle sprinklers should have a one gallon per minute nozzle. Mismatched precipitation from the sprinklers may be caused by: 1) mixing sprinklers in a zone, 2) improper replacement of worn nozzles, 3) errors in installation or design.

Three steps to improve the watering efficiency of this zone:

- 1) I recommend using a larger nozzle in the one full circle rotor in the front lawn. I recommend a (6.0) Rain Bird 5000 series nozzle.
- 2) TO match precipitation rates I recommend using a (6.) Rain Bird 5000 nozzle in the full circle rotor on this zone. This may also help keep your pump from cycling on and off during the zones run period.
- 3) I recommend a 60 minute run time for this zone.

Zone 4

(Left front lawn)

Sprinkler precipitation is not matched – Sprinklers in the same zone with different watering patterns (i.e. full, half, and quarter circle patterns) need to have their nozzle sizes adjusted. One of the most common causes of low uniformity is due to mismatched sprinklers nozzles in an irrigation unit. For example, if a zone has a full circle sprinkler with a four gallon per minute nozzle then any half circle sprinklers should have a two gallon per minute nozzle, and any quarter circle sprinklers should have a one gallon per minute nozzle. Mismatched precipitation from the sprinklers may be caused by: 1) mixing sprinklers in a zone, 2) improper replacement of worn nozzles, 3) errors in installation or design.

Three steps to improve the watering efficiency of this zone:

- 1) I recommend using a (6.0) Rain Bird 5000 series nozzle in the full circle rotor.
- 2) I recommend a 60 minute run time for this zone.
- 3) As you replace broken sprinklers stay with the same type and same manufacture throughout each zone.

Zone 5

(Back right lawn area by shop)

Excessive pavement water overflow – A significant amount of irrigation water is being applied onto shop on the right side. Adjustments in the sprinkler system's design may be required.

Sprinkler precipitation is not matched – Sprinklers in the same zone with different watering patterns (i.e. full, half, and quarter circle patterns) need to have their nozzle sizes adjusted. One of the most common causes of low uniformity is due to mismatched sprinklers nozzles in an irrigation unit. For example, if a zone has a full circle sprinkler with a four gallon per minute nozzle then any half circle sprinklers should have a two gallon per minute nozzle, and any quarter circle sprinklers should have a one gallon per minute nozzle. Mismatched precipitation from the sprinklers may be caused by: 1) mixing sprinklers in a zone, 2) improper replacement of worn nozzles, 3) errors in installation or design.

Four steps to improve the watering efficiency of this zone:

- 1) I recommend replacing the one rotor sprinkler on the right side property line with two smaller Rain Bird 3500 series rotors next to the shop to eliminate watering onto the building.
- 2) I recommend spacing the new Rain Bird 3500 series rotors 15'-20' apart next to the shop set at 180 degrees.
- 3) Since the distance to the adjoining property is less than 15 feet I recommend using (2.0) gallon 3500 series nozzles and tone down the streams so they water in your lawn only. This area would normally be irrigated by spray heads but since zone #5 is a rotor zone you must stay with rotor type sprinklers.
- 4) I recommend a 40 minute run time for this zone.

Zone 6
(Back and back left)

Obstructed sprinklers – Some of the sprinklers were blocked or covered by turf, blocked by plants, and/or blocked by other items. Clearing around, raising up, or moving the sprinkler heads will help the obstructed sprinklers.

Four steps to improve the watering efficiency of this zone:

- 1) I recommend raising a few spray heads by the seawall and left back property line.
- 2) I recommend a 20 minute run time for this zone.
- 3) You may consider lowering the flow rate on the SST nozzle in the back planter.
- 4) Rain Bird (SST) Side strip nozzles apply 1.21 gallons per minute @ 30 psi. In a contained area that is a lot of water!

If you change any of the sprinklers to improve the watering efficiency of your system, be sure to use the same brand of sprinkler within each zone. Different sprinkler brands and different sprinkler types within the same zone will cause uniformity problems and therefore waste water.

Once a month you should check the sprinkler system. Turn on each irrigation zone and look for leaks, sprinklers that are not turning, sprinklers that are watering paved areas/buildings/the neighbor's yard, grass and bushes that have grown over the sprinklers, and other things that will affect the system's performance. Five minutes of operating time for each zone is allowed for this inspection. Some problems can be corrected right away (such as wetting pattern adjustment), but for others you will probably want to take some notes and correct them later (such as broken pipes or sprinklers).

**PLEASE KEEP OUR FLORIDA CONSERVATION EFFORTS IN MIND AS YOU WATER.
FOR ALL WATERING GUIDELINES CALL S.F.W.M.D. 1-(239-338-2929)**

RECOMMENDED IRRIGATION SCHEDULE

Based on the program's calculations of your current system, the following schedule for each zone is recommended. The operating times reflect the fact that sprayheads deliver more water than rotor sprinklers. This irrigation duration should allow for a deeper development of turf roots, greater soil moisture storage, and promote a more drought tolerant turf. Observe local water restrictions and regulations. **It is best to water during the morning hours before sunrise.**

- Zone 1: 20 minutes
- Zone 2: 20 minutes
- Zone 3: 60 minutes
- Zone 4: 60 minutes
- Zone 5: 40 minutes
- Zone 6: 20 minutes

Based on your lawn type and soil type, it is recommended to follow the schedule below for the number of days between water applications. The differences in the number of days between irrigations reflect the fact that less water is required during the winter months than the summer months. **Water can be applied by rainfall or your sprinkler system.**

Month	Jan	Feb	Mar	Apr	May	Jun	Jul	Aug	Sep	Oct	Nov	Dec
Irrigation Interval(days)	5	4	3	2	2	3	3	3	3	3	4	4

This schedule alone represents a 33% reduction in water use versus your current schedule. Once the system adjustments mentioned above are made, even more water savings can be produced. A follow-up evaluation can be scheduled once the adjustments to your system and schedule are complete. The follow-up evaluation will allow us to show you how much water was saved by your adjustments.

When there is significant rainfall (greater than half an inch) between irrigations, do not use the sprinklers until the correct number of days have passed since the rainfall. This will require manual adjustments to automatic systems unless the system is equipped with a rain shut-off device.

Monitor the appearance of your lawn and use this schedule as a guide for best results on your turf management.

Zone	Current Schedule		New Schedule		
	Run Time (min)	Irrigations per year	Run Time (min)	Irrigations per year	Water Savings (gallons)
1	60	104	20	120	48,194
2	60	104	20	120	50,229
3	60	104	60	120	-26,770
4	60	104	60	120	-26,643
5	60	104	40	120	-1,204
6	60	104	20	120	50,268

WATER TEST RESULTS

Your irrigation water has been tested for Total Dissolved Solids (TDS) and pH. This test does not check for bacteria.

Water Analysis:

	Tests Results	Normal Range
pH	7.6	7.0-8.0
TDS ^{1/}	3100	<500 ppm

^{1/} Total Dissolved Solids
(ppm) parts per million

The water analysis portion of the irrigation evaluation program was designed for use with irrigation systems in agriculture fields. The test results are provided for your general information. Please contact your local health department for testing water that is to be used in the home.

The following is a table of safe TDS levels for commonly grown plants:

Plant	TDS Level (ppm)
Vegetables	<600
Citrus foliage	<900
Flowers, azaleas and tender plant foliage	<900
Orchids	<300
Succulent plants	<1200
Bahia grass	<1500
Root systems of woody plants, including citrus	<1800

St. Augustine grass will tolerate levels greater than 2,000 ppm, but injury may occur to surrounding shrubs.

ST. AUGUSTINE GRASS BMP'S - "BEST MANAGEMENT PRACTICES"

MOW 3-4 INCHES HIGH – The higher a lawn is mowed, the deeper the root system will grow. A deep, extensive root system is able to reach moisture deeper in the soil and is more capable of withstanding damage from soil-borne pests like nematodes and root diseases. A high cut also shades and discourages weeds.

RECYCLE GRASS CLIPPINGS – Lawn clippings can be left on the lawn to recycle nutrients. A plastic bag full of grass clippings contains as much as ¼ pound of organic nitrogen. Recycling clippings reduces the fertilizer needs of the lawn and also reduces solid waste loads to landfills.

FERTILIZE THE RIGHT WAY – A minimum of two fertilizations a year (March and September) may be all that is necessary to maintain your St. Augustine grass lawn. Apply a complete fertilizer such as 10-10-10 or 16-4-8. The last number on the fertilizer bag represents Potassium which supports root growth and drought resistance. The potassium level should never be less than half the amount of nitrogen. Additional applications of nitrogen may be made during the year if desired; however, maintenance requirements and pest problems will increase accordingly.

LET YOUR LAWN TELL YOU WHEN TO WATER – Your St. Augustine lawn will signal a need for water by folding the grass blades together. When 30%-40% of the lawn shows this symptom of wilt, it's time to water. Research has shown irrigating "as needed" can save significant amounts of water and will not diminish the quality of the lawn.

CONTROL PEST PROBLEMS – Nematodes are microscopic parasites that attack the roots of St. Augustine grass. This also diminishes the lawn's ability to absorb and conduct water. Watch for areas of lawn that wilt prematurely, thin out, and become weedy. A nematode test kit can be requested from the Cooperative Extension Service office in your county. Other insect pests of St. Augustine to watch out for are chinch bugs, caterpillars, and mole crickets.

The United States Department of Agriculture (USDA) prohibits discrimination in its programs on the basis of race, color, national origin, sex, religion, age, disability, political beliefs, and marital or familial status. (Not all prohibited bases apply to all programs.) Persons with disabilities who require alternative means for communication of program information (Braille, large print, audio tape, etc.) should contact the USDA, Office of Communications at (202) 720-5881 (voice) or (202) 720-7808 (TTD). USDA is an equal employment opportunity employer.

SUMMARY TABLE

RECOMMENDED PRACTICE	OPERATOR PRACTICE Yes/No
Automatic system	Y
Rain shut off	Y
No systems leaks	Y
Rain gauge	N
Controller Battery Back-up	N
Allow the lawn to wilt between irrigations	N
Mulching	Y
Irrigation stream clear of obstacles	N
All sprinkler heads are from the same manufacturer	Y
Minimum pressure 25 psi	N
Sprinklers are undamaged and operating properly	Y
Head orientation (up-right)	Y
Proper coverage	Y
Matched emitters	N
Rotors are in separate zones from spray heads	Y
Plant beds are in separate zones from turf	N

The summary table above lists some water conservation practices that, if followed, can decrease your water use. Practices that are currently being followed are indicated by the "Y" symbol.

4.8 Irrigation Water Management Plans

Irrigation water management (IWM) is the process of determining and controlling the volume, frequency, and application rate of irrigation water in a planned, efficient manner. Crop, soil and irrigation system information is used to develop an irrigation schedule that maintains soil moisture at a level that is optimum for plant growth, without a loss of water, soil or plant nutrients.

The objective of IWM is to provide irrigation decision makers an understanding of conservation irrigation principles by informing them on how they can judge the effectiveness of their own irrigation management practices and recognizing when adjustments need to be made to the system.

All IWM plans shall be in accordance with Florida NRCS conservation practice standard (CPS), Irrigation Water Management, Code 449. The minimum documentation requirements for CPS 449 can be found in NRCS NEH, Part 650, Florida Supplement, Chapter 1, Section A, Procedure for Documenting Planning, Design, Construction, and Checkout of Engineering Conservation Practices, this document is located in found in the FOTG, Section I., C. References, 1. Engineering References, e. Part 650, National Engineering Field Handbook – Florida Supplement, Chapter 1 – Engineering Surveys, at the following web address: <http://efotg.sc.e.gov.usda.gov/treemenuFS.aspx>.

The NEH, Part 652, Irrigation Guide, Florida Supplement, Chapter 10, contains example IWM plans for commonly used irrigation systems in Florida.

IWM plans prepared on behalf of NRCS shall be certified using forms FL-ENG-449A and B. NRCS personnel or others possessing the appropriate level of Engineering Job Approval Authority (EJAA) must sign the FL-ENG-449A form stating the IWM plan meets NRCS standards and specifications.

4.8.1 Sample Irrigation Water Management Plan for Center Pivot Sprinkler Irrigation System

IRRIGATION WATER MANAGEMENT PLAN

DATE: 4/13
COOPERATOR: Hurry I. Dry
LOCATION: Bellville
FIELD NUMBERS: 1
CROP: Corn
GROWING SEASON: February 15 – June 20
ROOTING DEPTH: 36 in
PEAK CONSUMPTIVE USE RATE: 0.23 in/day
IRRIGATION SYSTEM: Center pivot - 1314' span length, Pivot pressure = 38 psi, Capacity = 1100 GPM
WATER SUPPLY: Well
PREDOMINANT SOIL SERIES: Alpin sand

Table 1 – Operating Times for Various Rooting Depths and 50%MAD

Crop	Rooting Depth (inches)	^{1/} AWC (in)	^{2/} MAD (in)	^{3/} Gross Application Irrigation (in)	Critical Irrigation Period	^{4/} Dial Setting	^{4/} Time per Revolution (hours)
Corn	12"	0.67	0.34	0.40	Tasseling through silk stage until kernels become firm	88	20.60
	24"	1.27	0.64	0.75		47	38.57
	36"	1.87	0.94	1.11		32	56.66

^{1/} Available Water Capacity within the root zone (AWC).

^{2/} Management Allowable Depletion (MAD)

^{3/} Application depth necessary to replace water used by crop assuming an application efficiency of 85%

^{4/} Calculated from manufacturer's data. This should be re-calculated after checkout or evaluation.

CURRENT MANAGEMENT PRACTICE: None

RECOMMENDATIONS:

The most important aspect of irrigation water management is properly evaluating and monitoring the available soil moisture for the particular crop. By observing moisture levels in the soil, the operator can determine how long and how much water to apply. The landowner will be using the feel and appearance method. See attached feel and appearance worksheets.

The system is designed to meet peak consumptive use for corn on 125 acres.

Moisture should always be available above the MAD for the planned crops. The critical period is from tasseling through silk stage until the kernels become firm. The soil moisture should be checked to determine how much irrigation water should be applied for each irrigation. Prior to planting, or soon thereafter, the 12 inch root zone should be brought up to field capacity. If operated properly, irrigation can result in high crop production. The system should be managed to maintain a high moisture level in the root zone.

For planned crop yield, irrigation should commence when the available soil moisture drops below the MAD and should continue until the soil reaches field capacity. See Table 1 for how long to operate the system for various rooting depths and a MAD of 50%.

The irrigation system should be checked periodically to ensure proper operation of the pump, pipeline and sprinklers. No puddling should occur in the system. A visual inspection should be performed during operation to determine if any puddling or other irrigation-induced erosion is occurring. If so, increase the speed of the center pivot and the frequency of irrigation until no erosion occurs.

Check the condition of the crop to see if there is growth and if the crop looks consistent in color and height to determine adequacy and uniformity of the irrigation system.

Table 2 can be used to determine the time required per revolution, gross application and net application for various dial settings.

If there is change in the soil moisture monitoring method or irrigation method, contact the NRCS field office in Jasper, Florida.

TABLE 2: Time Required per Revolution, Gross Application, and Net Application

Dial Setting	Time Required per Revolution-Hours	Gross Application inches	Net Application inches
100	18.13	0.35	0.30
90	20.14	0.39	0.33
80	22.66	0.44	0.37
70	25.90	0.50	0.43
60	30.21	0.59	0.50
50	36.25	0.70	0.60
40	45.32	0.88	0.75
30	60.42	1.17	1.00
20	90.64	1.76	1.50
10	181.27	3.52	2.99

Cooperator: Hurry I. Dry

Field No. 1

Location: Bellville

Format for figuring the net amount of water required for an irrigation using the feel and appearance method of soil moisture measurements.

1	2	3	4	5	6
Depth feet	Soil Series Alpin Texture	Available Water Capacity Inches	Soil Water Content Before Irrigation		Soil Water deficiency inches
			percent	inches	
0-1	Coarse	0.67			
1-2	Coarse	0.60			
2-3	Coarse	0.60			
Total		1.87			

Column 1, the depth increment sampled.

Column 2, the soil texture of the sample.

Column 3, the available water capacity based on the texture of the sample.

Column 4, the percent of soil water content (remaining)

0-25% - AWC - Dry, loose, will hold together if not disturbed, loose sand grains on fingers with applied pressure.

25-50% - AWC – Slightly moist, forms a very weak ball with well-defined finger marks, light coating of loose and aggregated sand grains remains on fingers.

50-75% - AWC Moist, forms a weak ball with loose and aggregated sand grains, darkened color, moderate water staining on fingers, will not ribbon.

75-100% - AWC – Wet, forms a weak ball, loose and aggregated sand grains remain on fingers, darkened color, heavy water staining on fingers, will not ribbon.

100% - AWC – Wet, forms a weak ball, moderate to heavy soil/water coatings on fingers, wet outline of soft ball remains on hand.

Column 5, Column 3 x Column 4, the soil-moisture balance, inches.

Column 6, Column 3 - Column 5, soil-moisture deficiency or net irrigation requirement.

4.8.2 Sample Irrigation Water Management Plan for Traveling Gun Sprinkler Irrigation System

IRRIGATION WATER MANAGEMENT PLAN

DATE: 4/13

COOPERATOR: T.O. Dry, Jr.

LOCATION: T1N,R12E,S14, S.W. Jasper & S. of SR 6

FIELD NUMBER: 1

CROP: Watermelons

GROWING SEASON: March 15 – June 15

ROOTING DEPTH: 36 in

PEAK CONSUMPTIVE USE RATE: 0.19 in/day

IRRIGATION SYSTEM: Cable tow traveling gun with a wetted diameter of 418 feet and lane spacing of 260 feet using a Nelson 200 gun, 1.5-inch nozzle, 24 degree, at 85-psi nozzle pressure. Capacity = 460 GPM

WATER SUPPLY: 10” diameter well

PREDOMINATE SOIL SERIES: Alpin sand

Table 1 – Operating Times for Various Rooting Depths and 50% MAD

Crop	Rooting Depth (inches)	^{1/} AWC (inches)	^{2/} MAD (in)	^{3/} Gross application per irrigation (inches)	Critical Irrigation Period	^{4/} Travel Speed (ft/min)	^{4/} Time per 660' (hr.)
Watermelons	12”	0.67	0.34	0.52	Bloom to harvest	5.46	2.01
	24”	1.27	0.64	0.98		2.90	3.79
	36”	1.87	0.94	1.45		1.96	5.61

^{1/} Available Water Capacity within the root zone (AWC).

^{2/} Management Allowed Depletion (MAD) of 50%.

^{3/} Application depth necessary to replace water used by crop assuming an application efficiency of 65%.

^{4/} Some travelers will not reach the higher travel speeds. In this case, use the fastest speed available to keep water waste to a minimum.

CURRENT MANAGEMENT PRACTICE: None

RECOMMENDATIONS:

The most important aspect of irrigation water management is properly evaluating and monitoring the available soil moisture for the particular crop. The feel and appearance method will be used for determining soil moisture and when irrigation is needed. See attached feel and appearance worksheets.

The system is designed to provide irrigation water to meet peak consumptive use for watermelons in field 1 provided the acreage grown is not increased beyond 40 acres.

Moisture should always be available above the MAD for the planned crops. The critical periods for adequate available water are from blossom to harvest. The soil moisture should be checked to determine how much irrigation water should be applied for each irrigation. Prior to planting, or soon thereafter, the 12 inch root zone should be brought up to field capacity. If operated properly, irrigation can result in high crop production. The system should be managed to maintain a high moisture level in the root zone.

For planned crop yield, irrigation should commence when the available soil moisture drops below the MAD and should continue until the soil reaches field capacity. See Table 1 for how long to operate the system for various rooting depths and a MAD of 50%.

The irrigation system should be checked periodically to ensure proper operation of the pump, pipeline, risers and traveling gun. A visual inspection should be performed during operation to determine if significant puddling, runoff or other irrigation induced erosion is occurring. If so, increase the speed of the traveling gun and the frequency of the irrigation until no erosion occurs.

Check the condition of the crop to ensure that growth is occurring and that the crop looks consistent in color and height to determine adequacy and uniformity of irrigation. If the application is not uniform, a system evaluation should be performed.

If there is change in the soil moisture monitoring method or irrigation method, the NRCS office in Jasper, Florida should be contacted.

Cooperator: _____

Field No. _____

Location: _____

Format for figuring the net amount of water needed for an irrigation using the feel and appearance method of soil moisture measurements.

1 Depth feet	2 Soil Series Alpin Texture	3 Available Water Capacity inches	4		5	6 Soil Water deficiency inches
			Soil Water Content Before Irrigation			
			percent	inches		
0-1	Coarse	0.67				
1-2	Coarse	0.60				
2-3	Coarse	0.60				
Total		1.87				

Column 1, the depth increment sampled.

Column 2, the soil texture of the sample.

Column 3, the available water capacity based on the texture of the sample.

Column 4, the percent of soil water content (remaining)

0-25% - AWC - Dry, loose, will hold together if not disturbed, loose sand grains on fingers with applied pressure.

25-50% - AWC – Slightly moist, forms a very weak ball with well-defined finger marks, light coating of loose and aggregated sand grains remains on fingers.

50-75% - AWC Moist, forms a weak ball with loose and aggregated sand grains, darkened color, moderate water staining on fingers, will not ribbon.

75-100% - AWC – Wet, forms a weak ball, loose and aggregated sand grains remain on fingers, darkened color, heavy water staining on fingers, will not ribbon.

100% - AWC – Wet, forms a weak ball, moderate to heavy soil/water coatings on fingers, wet outline of soft ball remains on hand.

Column 5, Column 3 x Column 4, the soil-moisture balance, inches.

Column 6, Column 3 - Column 5, soil-moisture deficiency or net irrigation requirement.

4.8.3 Sample Irrigation Water Management Plan for Microirrigation System



NRCS Mobile Irrigation Lab
 2614 NW 43rd Street
 Gainesville, FL 32606
 Tel: 352-338-9562

Irrigation Water Management Plan	
Cooperator: <u>Hurry I. Dry</u>	Date: <u>October 1, 2009</u>
Location: <u>Need Water Rd</u>	Prepared by: <u>Erie Gator</u>
County: <u>Manatee</u>	Title: <u>Agricultural Engineer</u>
<p>Irrigation water management (IWM) is the process of determining and controlling the volume, frequency, and application rate of irrigation water in a planned and efficient manner. The objective is to maintain soil moisture at levels conducive to optimal plant growth and maximize irrigation efficiency. The most important aspect of IWM is to monitor the crop and soil moisture relationship. This can better be accomplished by the use of soil moisture sensors such as tensiometers.</p> <p>This IWM plan describes the techniques and strategies you will use to determine when and how much to irrigate. Changes in the system would affect the recommended operating times. If changes are made to the irrigation system, a new evaluation should be made. If you would like to change or correct this IWM Plan, please let us know by calling your NRCS Service Center.</p>	

Irrigation system type	Uniformity of water application will be determined by
<input checked="" type="checkbox"/> Sprayjets	<input checked="" type="checkbox"/> System evaluation
<input type="checkbox"/> Sprinkler	<input checked="" type="checkbox"/> Observation of water distribution
<input type="checkbox"/> Drip	<input checked="" type="checkbox"/> Observation of wetted area
<input type="checkbox"/> Subsurface	<input checked="" type="checkbox"/> Periodic pressure measurement
Water Source	Runoff caused by irrigation will be estimated by
<input checked="" type="checkbox"/> 14" Well	<input type="checkbox"/> Measurement of stream size
<input type="checkbox"/> Surface	<input type="checkbox"/> Observation
<input type="checkbox"/> Other	<input checked="" type="checkbox"/> Does not occur
Method used to determine when to irrigate	Method used to determine quantity of water needed
<input checked="" type="checkbox"/> Tensiometers	<input checked="" type="checkbox"/> Tensiometers
<input type="checkbox"/> Evaporation pan	<input checked="" type="checkbox"/> Soil feel and appearance
<input checked="" type="checkbox"/> Soil feel and appearance	<input checked="" type="checkbox"/> Leaf wilt
<input checked="" type="checkbox"/> Leaf wilt	<input checked="" type="checkbox"/> Scheduling guide
<input checked="" type="checkbox"/> Scheduling guide	<input type="checkbox"/> Water table depth
<input checked="" type="checkbox"/> Rainfall	<input checked="" type="checkbox"/> Rainfall
Application rate will be determined by	Soil erosion caused by irrigation will be estimated by
<input checked="" type="checkbox"/> System evaluation	<input type="checkbox"/> Measurement
<input checked="" type="checkbox"/> Emitter or sprinkler specs	<input type="checkbox"/> Observation
<input type="checkbox"/> Flowmeter	<input type="checkbox"/> Calculation
<input checked="" type="checkbox"/> Manifold Pressure	<input checked="" type="checkbox"/> Does not occur

4.8.4 Sample Irrigation Water Management Plan for Subsurface – Flow Through Irrigation System

IRRIGATION WATER MANAGEMENT PLAN

DATE:	4/13
COOPERATOR:	T.O. Dry, Jr.
LOCATION:	Sebring, Highlands County
FIELD NUMBER:	1
CROP:	Small Vegetables
GROWING SEASON:	December 1 – March 31
ROOTING DEPTH:	18 in
PEAK CONSUMPTIVE USE RATE:	0.18 in/day
IRRIGATION SYSTEM:	Flow-through subirrigation system with 28 furrows of different lengths on 60-foot spacing requiring a total of 161 gpm. Well capacity = 300 GPM at 5 feet drawdown.
WATER SUPPLY:	6" diameter well
PREDOMINATE SOIL SERIES:	Immokalee fine sand

A flow-through subirrigation system is to be installed. A minimum water delivery rate of 7 gpm/acre shall be available in order that your irrigation system meets the peak water demand period of the crop. A system which is capable of delivering 10 gpm/acre provides more management options and allows you to meet the peak water demand of the crop without running the pump for 24 hours a day.

The system shall be operated with the water table controlled within a range of 18 to 24 inches during crop establishment. Based on a peak consumptive use rate of 0.18 in/day, and a rate of upflux equal to 0.36 in/day, allow the water table depth to recede no lower than 28 inches below the top of the bed.

The water table depth from the top of the bed shall be determined using observation wells placed within the field. The observation wells can be made from 4 inch diameter PVC sand point (see enclosed observation well sheet) or with 4 inch diameter drain tile with sock. The wells are approximately 40 inches long and installed in the ground until the top of the well is level with the top of the bed. Two observation wells shall be installed at the highest and lowest areas of the field.

The system shall be operated until the water table is approximately 18 inches from the top of the bed. This point will be reached after an outflow (tailwater) of 1 - 2 hours has occurred at the downstream end of the field. At that time, the system shall be turned off. When the water table recedes to a depth of approximately 24 inches, the system shall be started again. Most of the water savings during the season will be possible during the early part of the season before the plants demand a great deal of water.

Using a water table depth range to determine the irrigation cycle is more practical and more accurately reflects the plant water use than trying to establish a regular irrigation interval such as two days on/one day off.

Soil moisture feel and appearance can be used to determine when to irrigate as per enclosed measuring soil moisture content sheet. Irrigate when soil moisture is 50% or less. Shut off irrigation system based on experience. It is recommended that observation wells be used in conjunction with the feel and appearance method.

The operator should consider correlating results from water table observation wells with those from soil moisture feel and appearance.

The irrigation system should be checked periodically to ensure proper operation of the system and to identify any problems with the system layout. A visual inspection should be performed during operation to determine if there are excessive tailwater losses to the system or significant erosion is occurring in furrows or ditches. Tailwater losses can be reduced by installing water table control structures in outlet drainage ditches, or allowing the water table to fluctuate within an allowable range. Water erosion can be controlled by structures at the ends of laterals, reducing the irrigation stream, structures in open ditches, and/or changing system layout to reduce slope in direction of irrigation.

Check the condition of the crop to ensure that growth is occurring and that the crop looks consistent in color and height to determine adequacy and uniformity of irrigation. If the application is not uniform, a system evaluation should be performed.

If there is change in the soil moisture monitoring method or irrigation method, the NRCS office in Sebring, Florida should be contacted.

4.8.5 Florida NRCS Form FL-ENG-449A



FL-ENG-449A

01/11

Irrigation Water Management

Sheet 1 of 1

Conservation District: _____ Location: _____
 Cooperator: _____ Field Office: _____
 Identification No.: _____ Field No.: _____ Contract No.: _____ Acres: _____
 Type of Irrigation System: _____

1. A conservation irrigation system which meets the requirements of field office technical guide is established on the land being irrigated. If no, briefly describe changes needed to meet NRCS standards. ^{1/}	Yes <input type="checkbox"/> No <input type="checkbox"/>	Comments:
2. Operator uses the irrigation water management (IWM) plan. ^{2/}		Comments:
a. to determine when to irrigate (i.e., an irrigation scheduling procedure). If yes, briefly describe method used.	Yes <input type="checkbox"/> No <input type="checkbox"/>	
b. as a method for measuring soil moisture. If yes, briefly describe how (i.e., using tensiometers, feel and appearance method).	Yes <input type="checkbox"/> No <input type="checkbox"/>	
c. as a method for measuring irrigation system application rate. If yes, briefly describe method used.	Yes <input type="checkbox"/> No <input type="checkbox"/>	
d. to adjust irrigation to compensate for changes in soil infiltration rate. If yes, briefly describe method used.	Yes <input type="checkbox"/> No <input type="checkbox"/>	
e. to recognize and control soil erosion caused by irrigation. If yes, briefly describe.	Yes <input type="checkbox"/> No <input type="checkbox"/>	
f. as a method for evaluating irrigation system uniformity set forth in the IWM plan. If yes, briefly describe how.	Yes <input type="checkbox"/> No <input type="checkbox"/>	
g. to schedule time needed for nutrient and chemical application. If yes, briefly describe how.	Yes <input type="checkbox"/> No <input type="checkbox"/>	
h. as a method for recognizing excess runoff by irrigation and make adjustments.	Yes <input type="checkbox"/> No <input type="checkbox"/>	
i. self certification documentation forms have been provided. ^{4/}	Yes <input type="checkbox"/> No <input type="checkbox"/>	

^{1/} If item 1 is checked no, the landowner will be provided in writing the requirements needed for the irrigation system to meet NRCS standards and specifications.

^{2/} All the above questions under item 2 must have affirmative or not applicable answers before certifying IWM.

^{3/} If needed, form FL-ENG-449B may be used for systematic recording technical assistance and progress made in applying this practice. Notes shall be dated and initialed each time IWM assistance is given.

^{4/} Form FL-ENG-449C must be completed by the landowner when self certification is required from the landowner. Form FL-ENG-449D is optional.

This practice has been applied as planned and meets NRCS standards and specifications.^{2/ 3/ 4/}
 _____ Title: _____ Date: _____
 Signed

CHAPTER 5. Resources

It is important that the MILs have the resources necessary to perform their job both in the field and in the office. Two of the most obvious resources are staff and equipment. Staffing needs and qualifications are discussed in Chapter 2 of MIL Administrative Handbook. Equipment is discussed in Chapters 2 of this handbook and Chapter 4 of the MIL Administrative Handbook.

There are other important tools/resources that apply to all MILs, independently of their type (agricultural, urban, or both). Those common tools/resources are: ongoing educating and/or training, so that the MIL members can review their job duties and responsibilities on a regular basis and stay up to date on the latest irrigation system evaluation methodologies; providing the MILs the means to consistently and comprehensively document and record information associated with irrigation system evaluations; and providing the MILs and its supporting entities and agencies the means to keep track of all the information associated with all the water conservation evaluations through the years. Such resources are typically available in the form of training, the development and use of forms, and an evaluation tracking system.

5.1 Training

There are two main areas in which training can be provided to an MIL, in-office procedures and field procedures.

The in-office procedures are typically associated with ways in which the MILs can take the data/information they collected via an evaluation, and use it to determine how well or poorly the irrigation system is operating (efficiency or distribution uniformity), how to improve the irrigation system (problems and recommendations), and how much water the system could potentially save (Potential Water Savings, PWS) or actually save (Actual Water Savings, AWS) if those recommendations were implemented.

The field procedures are typically associated with the type of equipment that is used to evaluate the irrigation system (i.e., pressure gauge), the manner by which the equipment is used (i.e., where and how to use that pressure gauge), and the method of data collection using that equipment and other sources (i.e., manually or electronically, at a certain frequency, at certain locations or distributions, etc.).

Both types of training are important. Only each MIL knows at any particular time what type of training its staff needs, to maximize the MILs performance. Because of its importance, it is recommended that training expenses be included in the yearly budget of an MIL as outlined in Chapter 3 of the MIL Administrative Handbook. It is also important to identify if the staff of your MIL has the education and background necessary to receive that training. In some instances, it may be necessary for some of your staff to attend certain introductory or core course(s) before he/she can attend that particular training. All MIL employees have been provided an employee development plan (EDP) which is used to gauge the proficiency levels of each MIL employee to determine necessary training needs to obtain a level of consistency in evaluations performed by all MILs throughout the state.

Once a particular training need has been identified, the MIL staff should look for a qualified provider that can offer training. A good place to start is to ask other MILs in the State about that

particular training need. One of those MILs may have had that same training and could provide it to your MIL, or direct you to the provider they used to obtain the training. The internet is another source, where both private and public providers can be identified and contacted.

Florida NRCS has historically provided excellent training to MILs (when available) for both office and field procedures. Contact the NRCS State Office in Gainesville to find out what training opportunities they may have at the time.

USDA, NRCS:

Web: <http://www.fl.nrcs.usda.gov/>
Phone: (352) 338-9500

Following are three other references where training may be provided, or where contact information for other providers may be available:

Irrigation Association (IA):

Web: <http://www.irrigation.org>
Phone: (703) 536-7080

Florida Section of the American Society of Agricultural and Biological Engineers (ASABE):

Web: <http://www.fl-asabe.org/index.html>
Phone: (863) 414-0710

Florida Irrigation Society (FIS):

Web: <http://www.fisstate.org/>
Phone: (800) 441-5341

5.2 MIL Evaluation Field Forms

It is important to provide consistency and validity to the information the MILs collect during their evaluation of irrigation systems. Without consistency and validity, it will be difficult for the MILs to make the most out of the water conservation information they collect and provide.

By using standard field forms in their day-to-day processes, the MILs continue to take big steps towards providing the best service they can to their customers, and the entities and agencies that support them. The MILs should strive to use as many standard and approved electronic field forms as possible (as opposed to paper forms), so that the information in those forms can be verified, shared, compiled, and retrieved as quickly and easily as possible by all interested parties.

The MILs and their partner entities and agencies continue to develop and/or update those field forms as applicable, to meet the needs of the MILs and all interested parties, for both agricultural and urban settings.

These field forms are typically in an electronic word processing or spreadsheet format, for ease of use and data transfer. Typically, the master electronic copies of those forms reside with the executive committee of the ICC to which most MILs belong, and the FDACS, NRCS, or a water management district. Any MIL that needs any of the field forms should contact one of these institutions or agencies.

Any modifications proposed to these field forms or the creation of additional field forms should be discussed in advance by all interested parties (the MILs themselves, NRCS, FDACS, and/or water management districts among others). Approval of such modifications or additional field forms should be formally discussed during the ICC meetings by those same parties.

THIS PAGE INTENTIONALLY LEFT BLANK

CHAPTER 6. Irrigation Safety

There are many situations that could result in bodily harm or death when working around irrigation systems. Injury can result from exposure to electrical contacts, entanglements with moving parts, chemical exposure, excessive pressure build up, parts falling from the system, and drowning.

Individuals working around any type of irrigation system shall complete safety training, due diligence research of the installation, and a commensurate safety investigation of the site prior to performing an irrigation system evaluation. All irrigation systems and appurtenances should be considered unsafe regardless of appearance or operational status.

To ensure safety during irrigation system evaluations, MIL staff must be aware of potential hazards that may be encountered onsite and be knowledgeable of safe work practices necessary to work around the system. Potential hazards can be caused by faulty equipment or installation, poor maintenance by the owner, and unsafe work practices by individuals during maintenance, repair and/or testing.

To protect themselves and others when working around electrically-powered irrigation systems, MIL staff should wear the appropriate clothing and use necessary personal protective equipment (PPE) when working around irrigation systems, visually inspect the irrigation system prior to touching any components, and know how to operate test equipment such as a voltmeter to check for stray electrical current or faulty grounding.

If any unsafe work practice or hazard is suspected or observed, halt the irrigation evaluation and notify the landowner or farm manager immediately to prevent injury.

THIS PAGE INTENTIONALLY LEFT BLANK

Appendix A - Irrigation System Problems and Codes

THIS PAGE INTENTIONALLY LEFT BLANK

Below are the irrigation system or management factors that limit irrigation system performance or efficiency, which were noted during the system evaluation, and/or thorough discussion with the irrigator. The code numbers in this table are used in any applicable MIL reports, to document those problems in those reports.

Database Code	Description of Problems
<u>PRESSURE AND/OR IRRIGATION RATE</u>	
Detailed List	
1	Under-sized pump for number and type of sprinkler heads or emitters
2	Pressure loss between pump and sprinklers/emitters due to inadequate pipe size
3	Higher pressure than manufacturer's specifications
4	Lower pressure than manufacturer's specifications
5	Low pressure due to water supply
6	Different pressure between manifolds
7	Wetted area not adequate for crop requirement
8	Application rate > soil infiltration rate (ponding)
9	Air in pipelines
10	Turf and landscape area irrigated in the same zone
11	Pressure variation due to elevation differences
12	Missing/malfunctioning pressure gauge/regulator/filter
13	Mixed Crops or container with different water requirements in the same zone
Generic List	
101	Too High or Low Pressure at Pump Station
102	Too High or Low Flow at Pump Station
103	Uneven pressure distribution across manifold(s) and/or lateral(s)
104	Uneven irrigation distribution across lateral(s)
<u>EMITTERS AND/OR SPRINKLERS</u>	
Detailed List	
20	Mixed sprinkler/emitter sizes & unmatched precipitation in the same zone
21	Mixed sprinkler/emitter brands or types in the same zone
22	Poor emitter/sprinkler uniformity due to worn orifice
23	Poor overlap due to improper sprinkler/emitter alignment or spacing
24	Various riser heights in same zone
25	Emitter/sprinkler spacing varies in same zone
26	Missing/malfunctioning emitters or sprinklers
27	End Gun is out of adjustment or not operating

Database Code	Description of Problems
Generic List	
201	Mixed sprinkler/emitter sizes
202	Mixed sprinkler/emitter brands
203	Missing and/or broken emitters or sprinklers
204	Wrong emitter or sprinkler size and/or spacing for type and/or layout of crop
<u>MAINTENANCE</u>	
Detailed List	
30	Leaks and broken valves, pipe, laterals lines (Poly-tubing), emitters, sprinklers
31	Clogged filter or filter screen
32	Sprinkler heads not properly adjusted
33	Clogged emitters/nozzles (due to biological, chemical or physical factors)
34	Leaning sprinklers/emitters causing non-uniform distribution
35	Malfunctioning valves
36	Control box in need of repair
37	Boot Leak
38	System has no booster pump
40	Stream of water blocked by vegetation
41	Variable crop spacing and stage of growth
42	Poor drainage, requiring water control
Generic List	
301	Pump Station Engine and/or Pump leaks or malfunctions
302	Filter leaks, clogged, or malfunctions
303	Pipe Leaks in Irrigation System
304	Valve(s) Malfunction(s) or Leak(s) in Irrigation System
305	Emitters and/or Sprinklers leaks, clogged, or malfunctioning
<u>OPERATION AND/OR MANAGEMENT</u>	
Detailed List	
50	Operating time too long
51	Operating time too short
52	Operating time too frequent
53	No rain shut-off device
54	No soil moisture measuring device or rain gage
55	No irrigation water management plan
56	No tachometer
57	Contamination of water with oil and fuel

Database Code	<u>Description of Problems</u>
Generic List	
501	Irrigation System Running too Long
502	Irrigation System not Running Long Enough
503	Inappropriate Irrigation Frequency
504	Inappropriate Irrigation System for type of crop
505	Abandoned and/or Inoperable Irrigation System

THIS PAGE INTENTIONALLY LEFT BLANK

APPENDIX B - Procedures for Accessing NRCS Web Soil Survey

THIS PAGE INTENTIONALLY LEFT BLANK

Procedures for Accessing NRCS Web Soil Survey

Soil survey maps for the areas mapped in the state are now available online through the NRCS Web Soil Survey (WSS), <http://websoilsurvey.nrcs.usda.gov/app/>. The WSS is replacing the familiar, traditional paper copies of soil survey reports. As new and updated soil surveys are completed, NRCS is distributing the results of these surveys by means of the WSS instead of published reports. The WSS allows NRCS to update the information more rapidly and ensures a single source for official data. Those without computer access can still acquire soil survey information from an NRCS field office or local library. The following procedures will demonstrate how to use and access the NRCS WSS.

Once the WSS website is accessed, Click on “Start WSS” button.

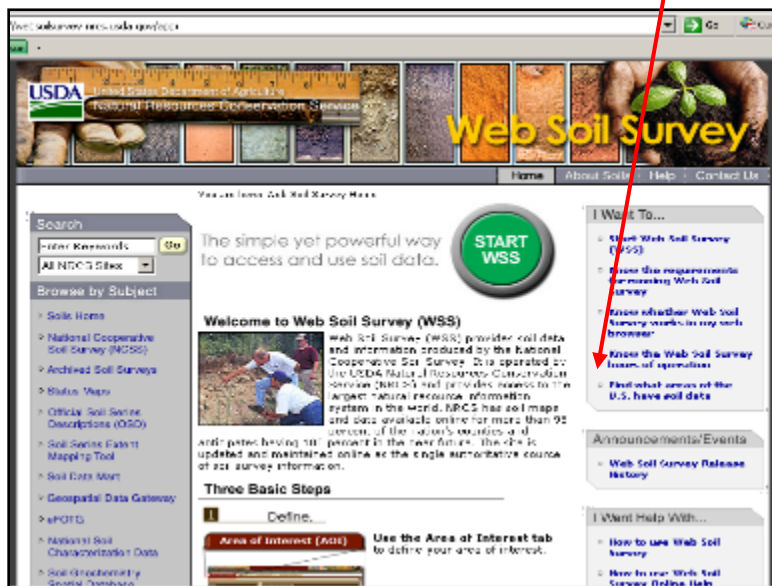

There are four (4) basic steps in using WSS:

1. Define,
2. View,
3. Explore, and
4. Check Out.

DEFINE:

The first step in using WSS is to define your area of interest.

You can select an area in the continental United States, Alaska, Hawaii, the Pacific Basin, Puerto Rico, or the U.S. Virgin Islands. You select an area by zooming in on a locator map or by specifying street address, county, survey area, coordinates, PLSS, or Hydrologic Unit.

You can navigate to your area of interest (AOI) and define it using either the Selection Criteria in the left column or the use the Interactive Map.

There are four (4) methods to define and navigate to an Area of Interest (AOI) depending on your familiarity with your AOI. Search (Basic or Advanced), Import AOI (Shapefile or Zipped Shapefile), Quick Navigation, or by using the Zoom tool. They are located on the panel left of the interactive map. Click on the “Help” icon in the upper right hand corner. The “Help” button reveals additional information about performing your search and defining your Area of Interest.



The “Help” button reveals additional information about performing your search and defining your AOI.

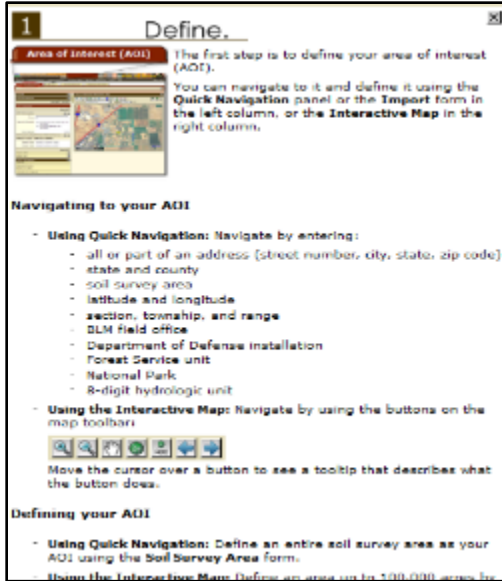

Note: The specified AOI must be smaller than 10,000 acres.

To define AOI using a shapefile, the user must navigate to the directory containing the shapefile and associated files (.shp, .shx, prj). Once all three (3) files have been selected, Click the “Set AOI” button.

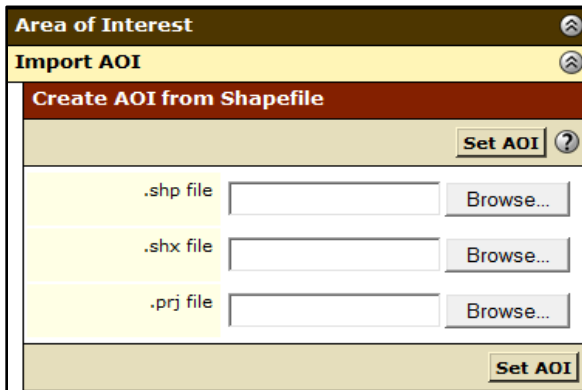

The zipped shapefile option allows the user to create an AOI using a zipped shapefile saved in some other application or re-open an AOI previously created in WSS and exported using the Export AOI function. The selected zip file must contain the shapefile and its associated files (.shp, .shx, prj). Once the zip file has been selected, click the “Set AOI” button.

Area of Interest

Import AOI

Create AOI from Shapefile

Create AOI from Zipped Shapefile

?

.zip file

For this example, using Quick Navigation (Navigate by State and County) on the left side of the screen, SELECT Citrus County, Florida and click the View button.

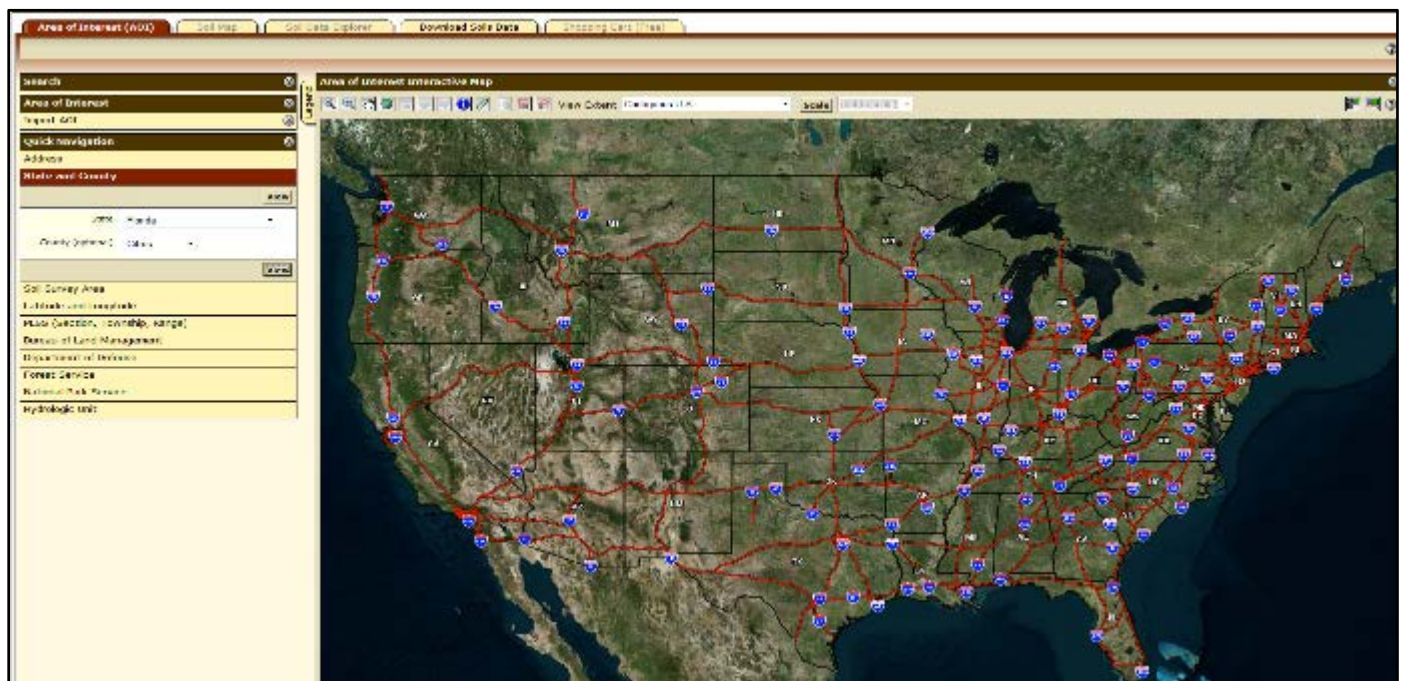

Using the Zoom tool, choose the exact area for viewing. For this example, zoom in to Beverly Hills, Florida as shown by the red square below.

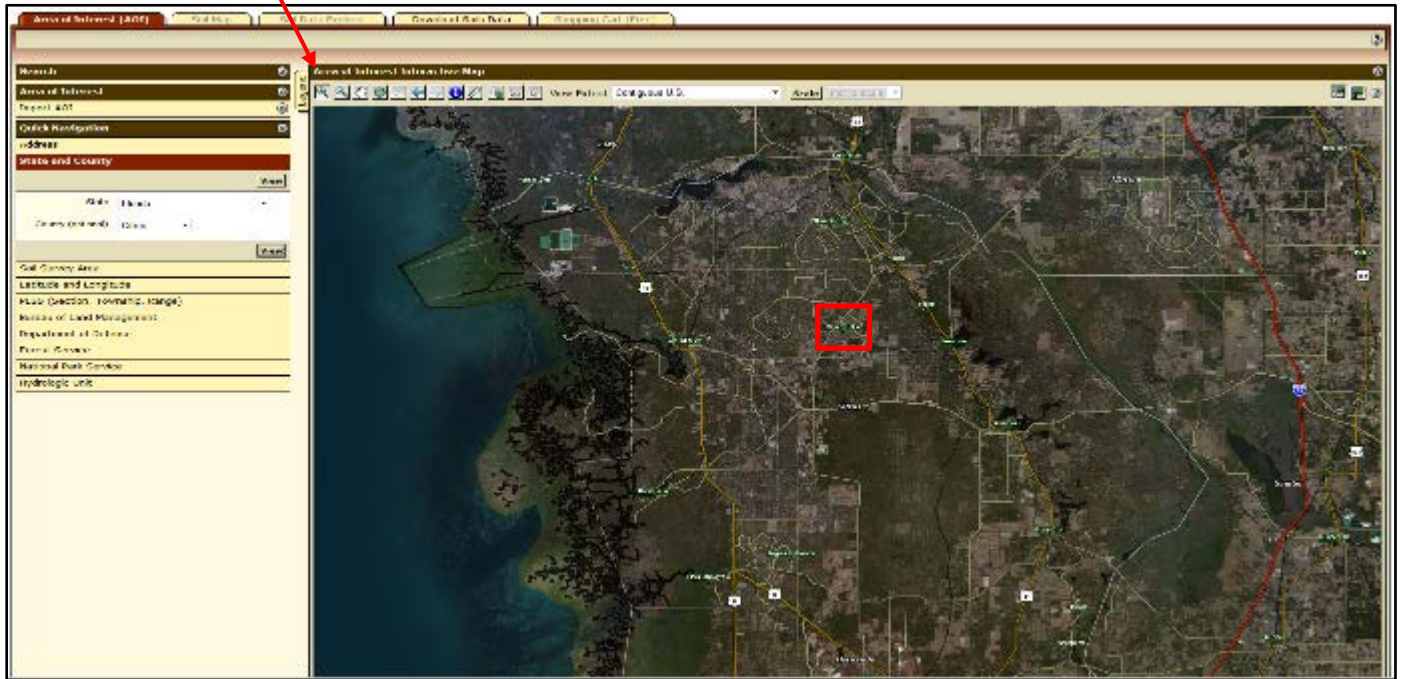

To define the AOI, use the Interactive Map, and select the button at the top of the page with the red rectangular AOI label. This selection will show a crosshair that will allow you to select the preferred area in rectangular shape. The AOI button to the right, allows for irregular AOI delineations.

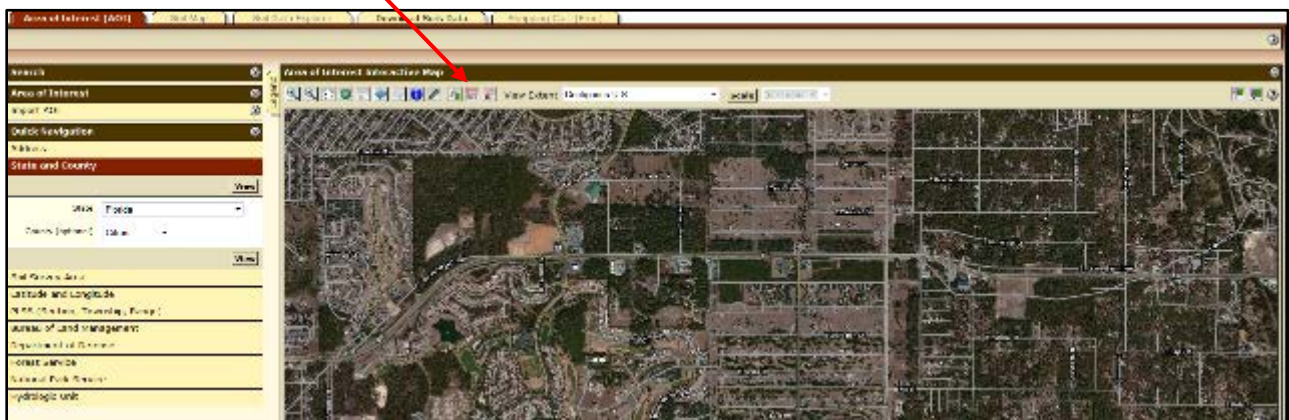

The defined AOI will show up in a crosshatched pattern and the soil data within your AOI ready for viewing.



You can customize your map layout by clicking on the Legend tab on the left side of the Interactive Map pane.



The AOI can be displayed with a topographic map background. This option can be selected in the Legend tab.

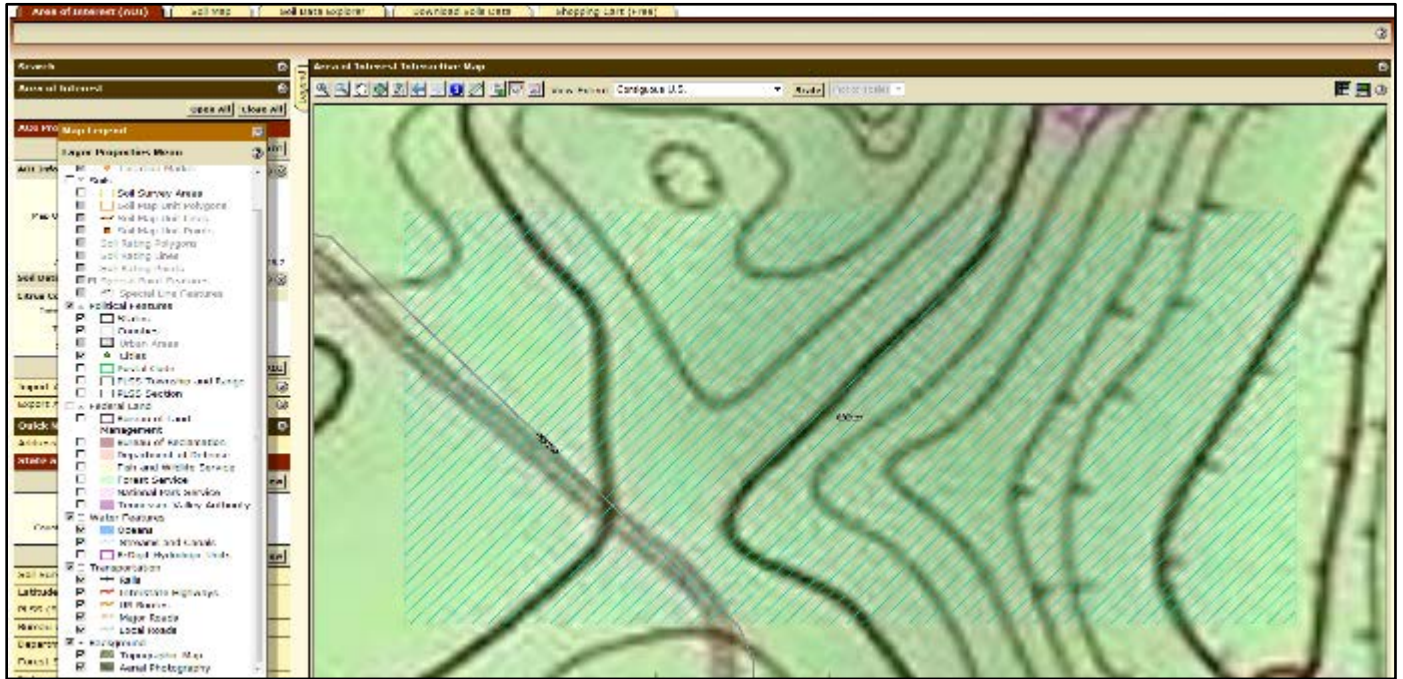

By right-clicking on an item in Map Legend, you can further customize the look and feel of the map you are creating.

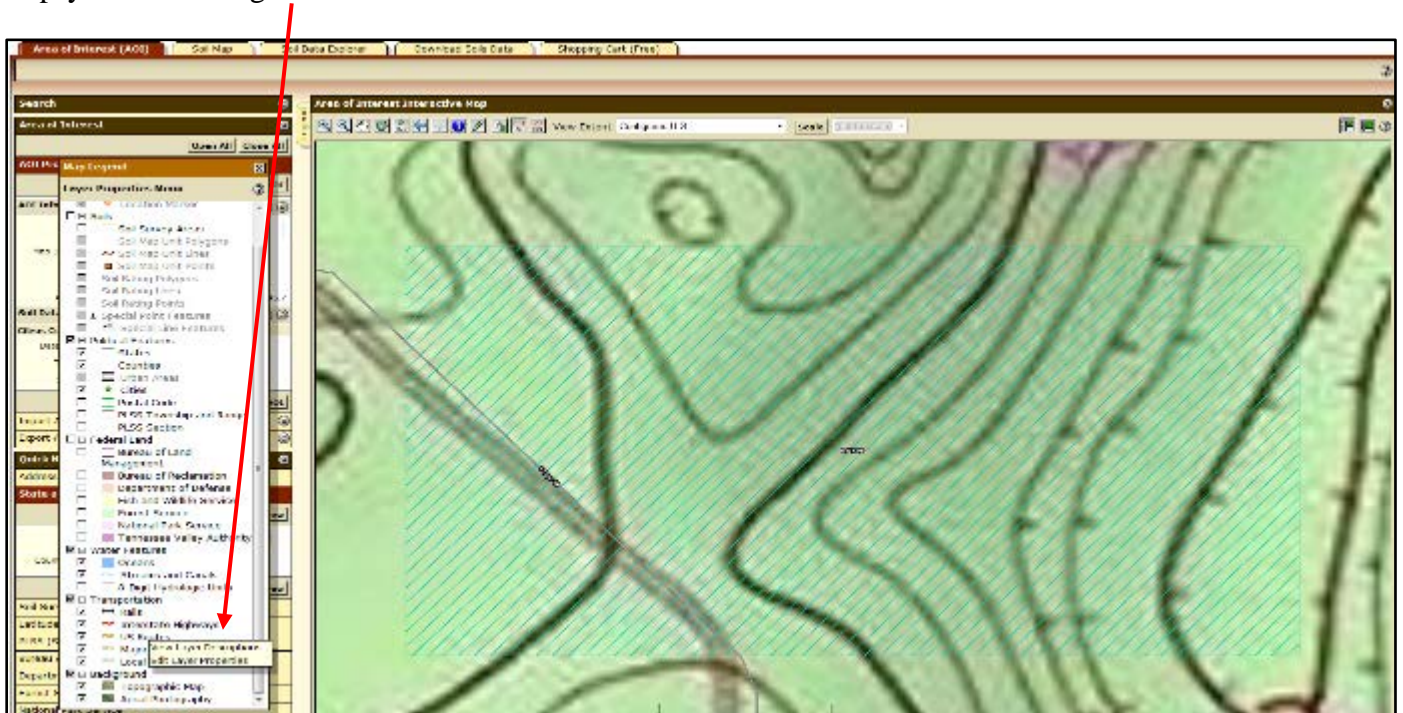

VIEW:

The second step in using WSS is to look at the Soil Map for the defined AOI. Click on the Soil Map tab near the top of the WSS window. The soil map shows the map unit symbols within the defined AOI.

The Map Unit Legend in the left column displays the map unit name and map unit symbol of each map unit, the percent of each map unit within the AOI, and the total acreage of each map unit within the AOI.

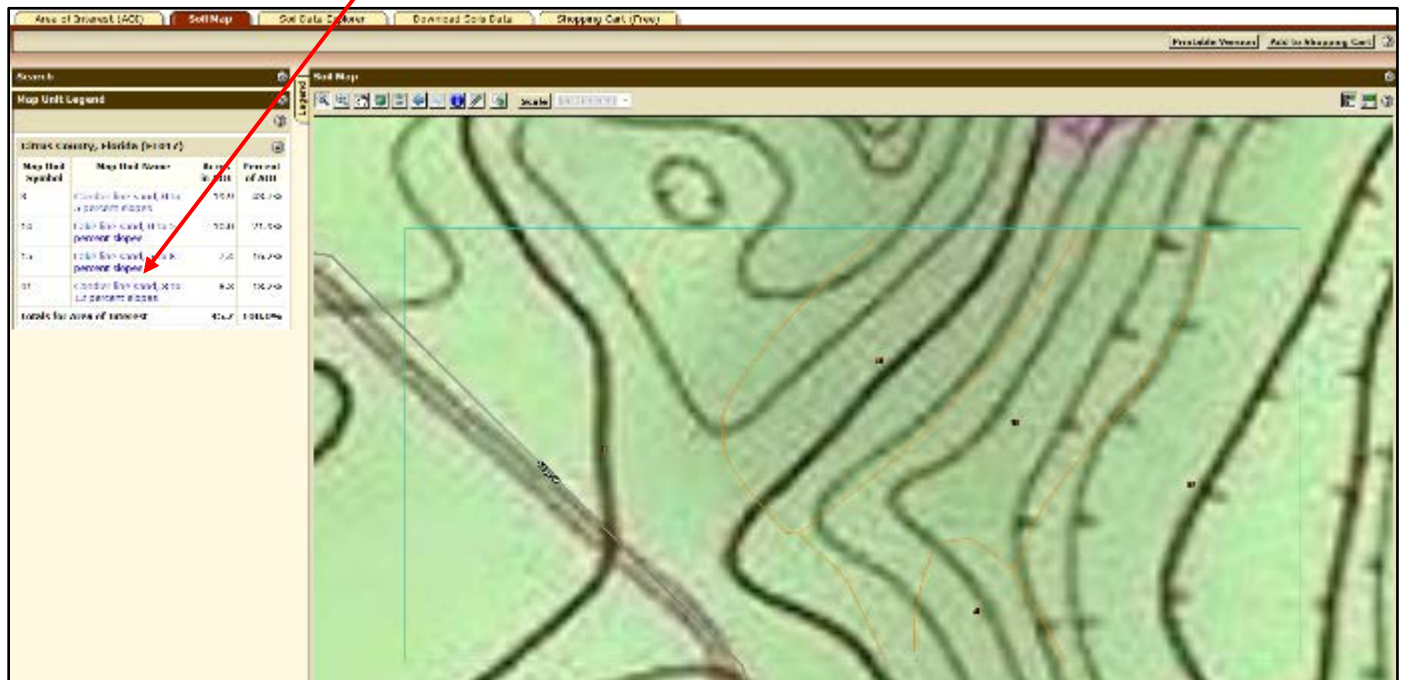

Note: Soil maps are not yet available for all areas. The maps that are available consist of aerial photography overlain by lines that indicate the boundaries of the various soil types.

For additional information on the functionality of the Soil Map tools, click on the Help icon on the Soil Map screen.

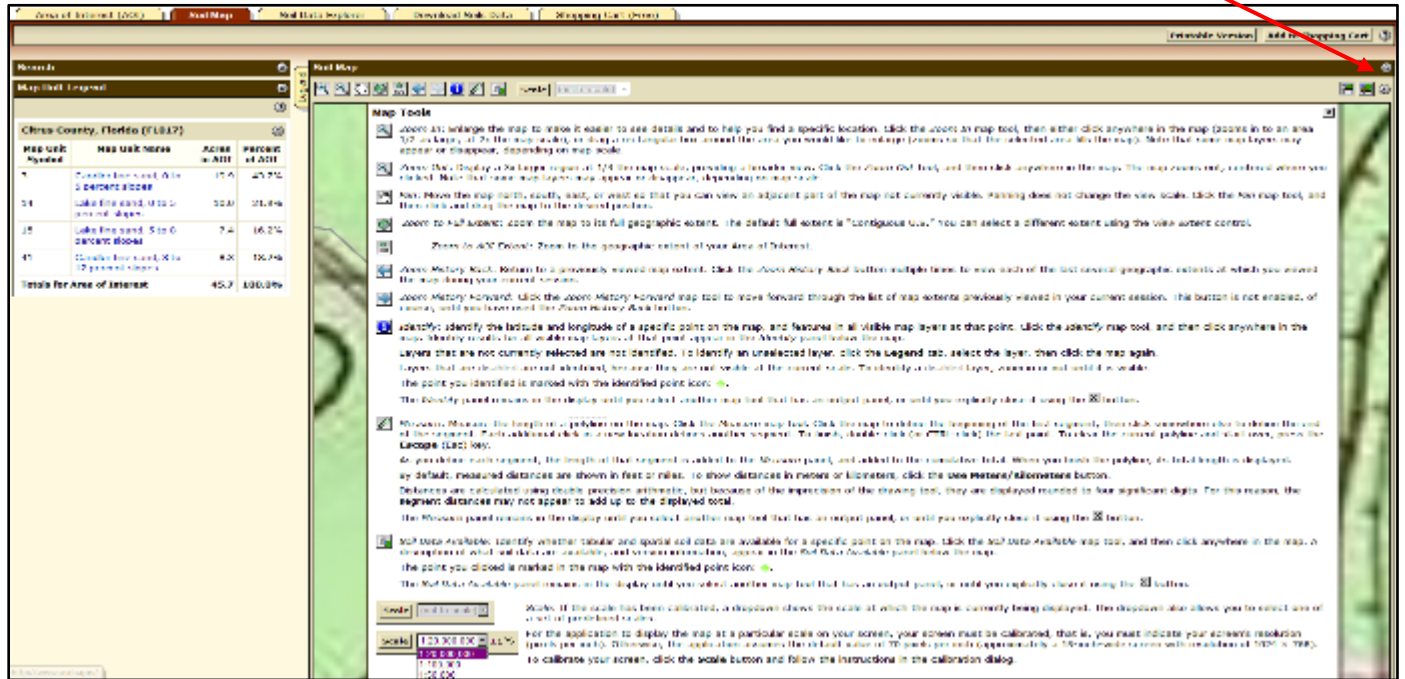

Viewing and printing the soil map

At this point in the process, there are three (3) options, create a Printable Soil Map, Explore additional Soil Data, or Add the Soil Map to the Shopping Cart.



While using WSS, you may want to refer back to your soil map. You can do so on the screen by clicking the Soil Map tab, or the soil map can be printed by clicking the Save or Print button. Click on the Help button for more information on Printing or Shopping Cart functionality.



EXPLORE:

The third step in using WSS is to explore all of the available information associated with the soils in the defined AOI. The Soil Data Explorer tab provides several ways of obtaining the relevant information.

Information about uses, management, soil properties, or interpretations can be viewed by clicking on the Intro to Soils Tab and selecting Topics. In the caption below, Irrigation Water Management (IWM) was the selected topic. Click "View Selected Topics" and the content is displayed. The content can be printed from WSS. The IWM content would be ideal to include in IWM plans and irrigation evaluation reports for MIL clients.

The screenshot shows the 'Soil Data Explorer' application with the following content:

Table of Contents:

- All Uses
 - Introduction to Soils
 - Soils 101
 - Information for Land Users
 - Homebuyers
 - Land Use Planners
 - Appraisers
 - Developers and Builders
 - Waste Disposal Entities
 - Park Boards and Recreation Area Planners
 - Construction Engineers
 - Farmers and Ranchers
 - How soil surveys can help farmers
 - How soil surveys can help ranchers
 - What soil data are available?
 - Cropland
 - Land capability classification
 - Soil erosion and crop production
 - Cropland management
 - Crop rotation
 - Crop residue management
 - Nutrient management
 - Pest management
 - Irrigation water management (IWM)
 - Contour farming
 - Contour stripcropping

Content Pane:

All Uses

Introduction to Soils

Cropland

Cropland management

Irrigation water management (IWM)

Definition: IWM is the process of determining and controlling the amount of irrigation water and the timing and rate of its application so that crop moisture requirements are met at the same time that water losses and soil erosion are minimized.

How this practice works: IWM matches irrigation water application to the needs of the crop and the infiltration rate of the soil and thus helps to reduce surface runoff during irrigation and prevent excessive soil erosion and loss of nutrients. Properly timing the water application maximizes the beneficial effects of pesticides and yet reduces the chance of loss from leaching or runoff. Properly designed and managed irrigation and drainage systems remove runoff and leachate efficiently, control deep percolation, minimize the erosion caused by the applied water, and reduce adverse impacts on surface water and ground water.

The volume of irrigation water applied and the frequency of irrigation should be determined by crop needs and soil characteristics. Soil moisture should be monitored to determine when application is needed to prevent crop stress and limit deep percolation. The volume of irrigation water applied should match the water-holding capacity of the soil in the root zone of the crop. The application rate should not greatly exceed the absorption or infiltration rate of the soil. When fertigation or chemigation is used, wells must be equipped with check valves and anti-siphon devices to prevent well contamination, which can lead to contamination of the aquifer.

Pollution process: Pollution is the result of a series of factors. These can be categorized as availability, detachment, and transport. Water pollution is a hazard only when a pollutant is available in some form in the field, becomes detached, and is transported beyond the edge of the field, below the root zone, or above the crop canopy and toward a receiving water body.

Availability: A potentially polluting substance is available in some amount and in some place. The potential pollutant could be sediment from a highly erosive soil since soil is always available. Chemical compounds vary not only in quantity but also in the degree of their availability for movement. The amount available at the time of runoff or deep percolation is important. Nutrients from fertilizer in or on the soil or from mineralized crop residue, pesticides applied to the field, bacteria carried with an application of animal manure, or some other potentially harmful material have different forms and times of availability for movement.

Additional functionality of the Soil Data Explorer includes viewing Suitabilities and Limitations for Use, Soil Properties and Qualities, or Ecological Site Information for the defined AOI.

Examples of Suitabilities and Limitations for Use include interpretations about how productive the soils are for various crops, and about how well suited the soils would be for various types of irrigation systems. If a soil has a rating value of 1.00 it is absolutely true that the soil is limited to irrigation, micro (above ground) due to seepage and low water holding capacity. Values between 0 and 1 are somewhere in between (neither absolutely true or absolutely false). The information can be displayed in tables and, in most cases, on maps. The Suitabilities and Limitations for Use shown below was used to check the soil suitability and limitations for above ground microirrigation. As the graphic displays, these soil types are not suitable for irrigation for various reasons. This information can also be view on the soils map, the soil map units that are red have limitations, green indicates no limitations.

Summary by Map Unit: Citrus County, Florida (FL017)

Map unit symbol	Map unit name	Rating	Drainage area (percent)	Rating criteria (numeric values)	Area as % of	Percent of RSD
2	Loose fine sand, 0 to 5 percent slope	Very limited	Candler (90%)	Seepage (L,00)	48.9	52.7%
			Lawson (10%)	Low water holding capacity (1.00)		
				Low water holding capacity (1.00)		
			Millapine (1%)	Seepage (L,00)		
				Seepage (L,00)		
			Acornville (2%)	Seepage (L,00)		
				Low water holding capacity (0.75)		
				Depth to saturated zone (1.00)		
14	Loose fine sand, 0 to 5 percent slope	Very limited	Lake (100%)	Seepage (L,00)	20.0	21.9%
				Low water holding capacity (0.75)		
			Woodlands (5%)	Seepage (L,00)		
				Low water holding capacity (0.52)		
			Walden (1%)	Seepage (L,00)		
				Low water holding capacity (1.00)		
			Tavares (5%)	Low water holding capacity (1.00)		
				Seepage (L,00)		
				Top add (L,00)		
			Candler (5%)	Seepage (L,00)		
				Low water holding capacity (1.00)		
15	Loose fine sand, 0 to 5 percent slope	Very limited	Lake (100%)	Seepage (L,00)	7.0	64.6%
				Low water holding capacity (0.50)		
			Lawson (1%)	Low water holding capacity (1.00)		
				Seepage (L,00)		
			Woodlands (1%)	Seepage (L,00)		
				Low water holding capacity (1.00)		
			Woodlands (1%)	Seepage (L,00)		
				Low water holding capacity (1.00)		



Examples of Soil Properties and Qualities include representative slope, available water capacity, and pH.

Make a decision to either Print the map or Save it to the shopping cart.

Note: After creating a map and table, the information can be printed or saved into the Shopping Cart. Upon printing or saving your map and related table, you will be prompted to Create a Subtitle for the map. For example, Title: John Doe; Subtitle: Beverly Hills, Florida.

If all the information you desire is a single map and table, you may create and print the map by clicking the “Printable Version” button at the upper right of the map layout. This will print all of the data and tables for the select property or use.

Map unit symbol	Map unit name	Rating	Component name (Grouped)	Soil Properties (measured values)	Area in AOI	Percent of AOI
23	Cassia Fine sand, 0.1% clay, 0.1% silt, 99.8% sand	Very lo Sand	Cation (22%)	Exchange (1.22)	18.8	82.7%
			Low water	Field cap (0.02)		
			High water	Field cap (0.02)		
			Medium (20)	Exchange (1.50)		
			Low water	Field cap (0.02)		
			High water (20)	Exchange (1.22)		
24	Lakeland sand, 0.1% clay, 0.1% silt, 99.8% sand	Very lo Sand	Lake (20%)	Exchange (1.22)	12.2	21.9%
			Low water	Field cap (0.02)		
			High water	Field cap (0.02)		
			Medium (20)	Exchange (1.50)		
			Low water	Field cap (0.02)		
			High water (20)	Exchange (1.22)		

However, if you want to build a detailed Soils Report of multiple maps and tables, and publish into a Soil Survey manuscript, you need to check the map/table into the Shopping Cart. So, you would need to add each specific map and table to the Shopping Cart.

After adding all of the maps and tables to the Shopping Cart, click on the Shopping Cart tab. This prompts you for selecting your report options.

An example of Soil Properties and Qualities. In this case, under Soil Physical Properties, select Available Water Capacity to view available water capacity of each soil map unit within the defined AOI.



An example of Ecological Site Assessment ratings and related Site information.

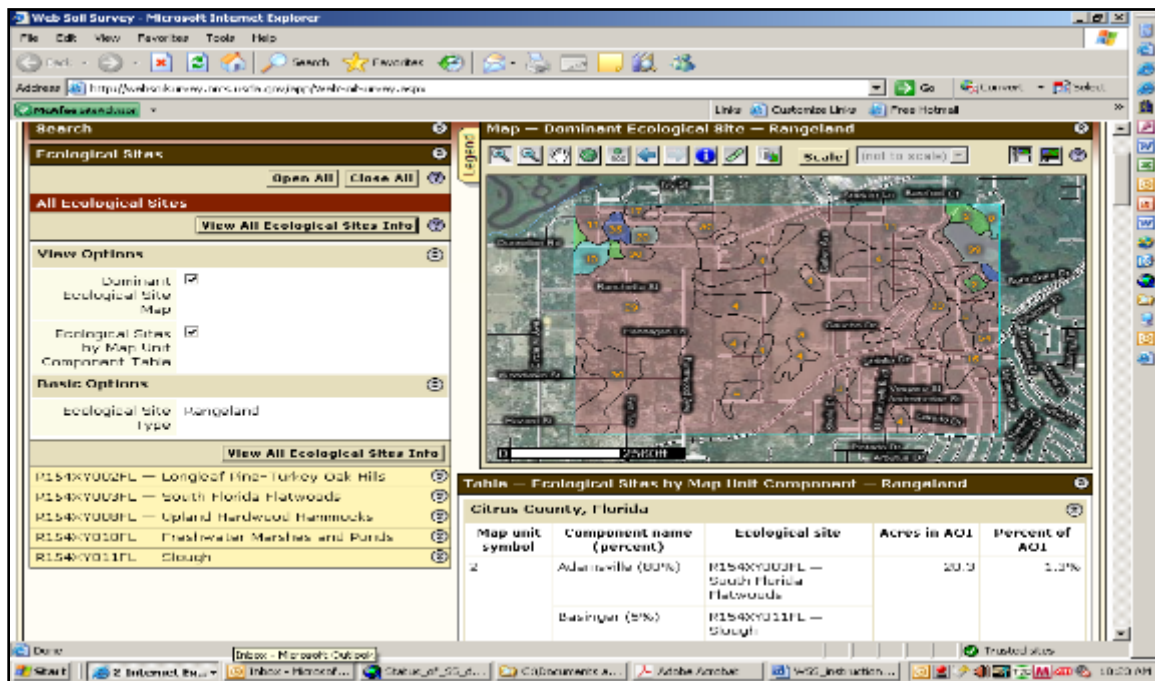

Note: The Ecological Site Assessment ratings are not available if there is no rangeland or forestland within the defined AOI.

GENERATING A CUSTOM SOIL REPORT:

After creating and placing maps and tables into the Shopping Cart, click on the Shopping Cart tab. This tab allows you to customize the soil survey for the defined AOI. You may add Custom

Subtitle, modify your map options (size, scale), and to select the desired components for your Soil Report. In this example, we will go with the Reports Default values with the exception of adding a Custom Subtitle and a Map Scale. The map scale shown in Report Properties is a fractional scale and not a true map scale. To convert this fractional scale to a true map scale, divide the fractional scale by 12. For example, in the graphic below, a map scale of 1:7,920 was selected, the true map scale will be 1" = 660' (7,920/12) on the printed map.

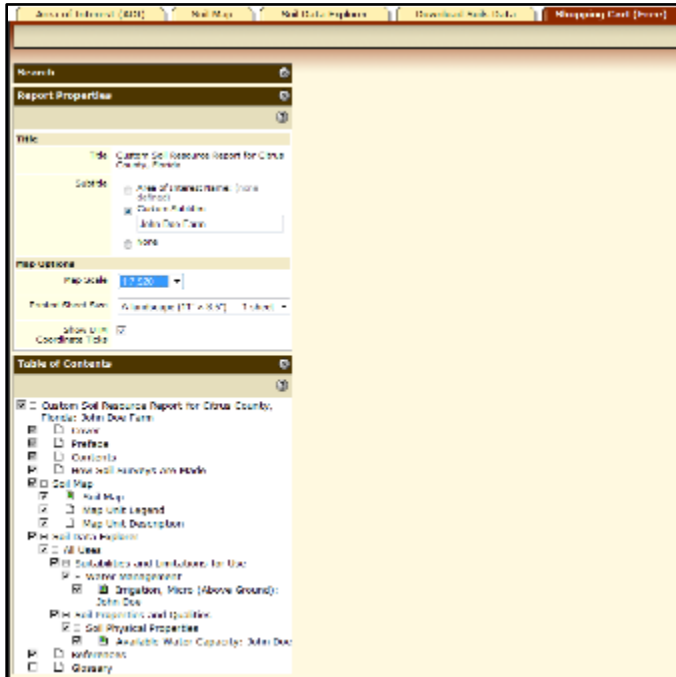

After selecting or deselecting the desired Report Features, click on each of the report components to determine how the report will display. For example, let's view the Map Unit Description format in the Report.

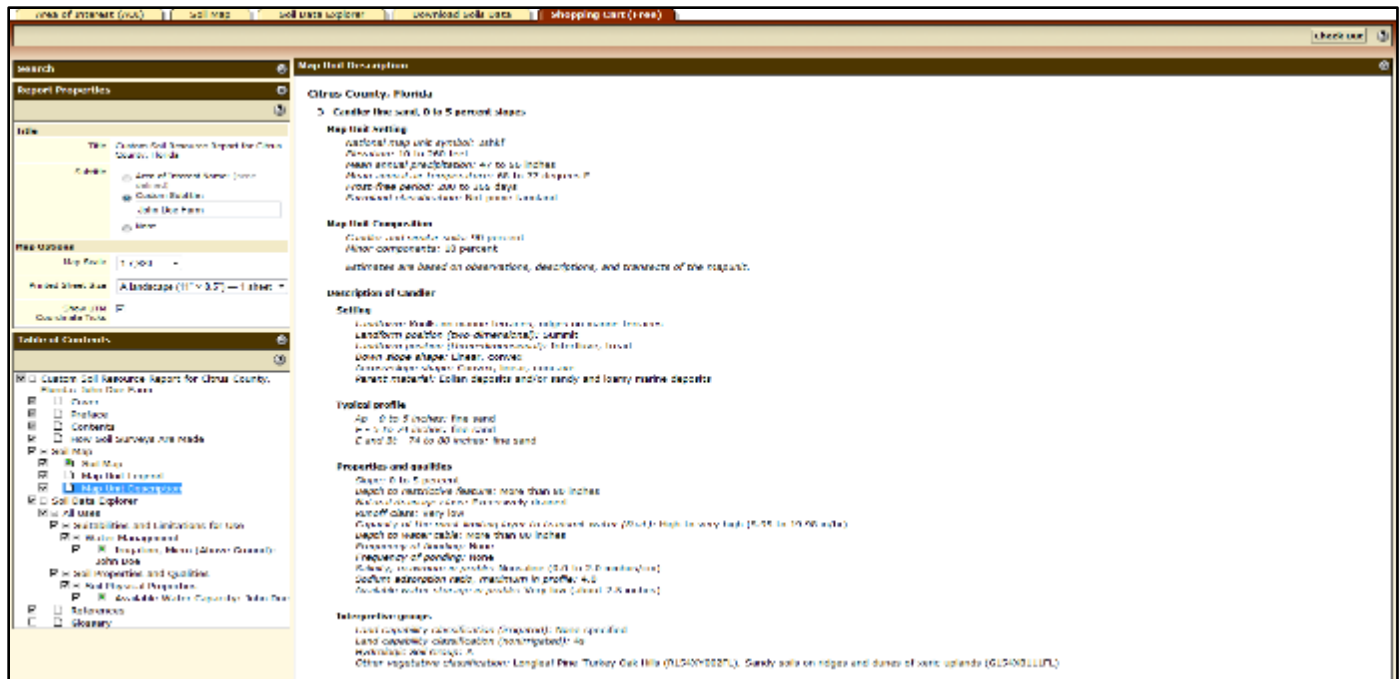

If there's a component of the report you do not wish to include, simply click the "radio button" to uncheck.

Checkout:

The fourth and final step in using WSS is to generate the final reports and maps that were added to the shopping cart.

Upon final customization of the report, click the Checkout button at the top of the page. You have two (2) options: Get Now or Download later.



Upon generating the report, the final report can be saved in PDF format. It will have the content and features of an Official Soil Survey document. Note that the Custom Subtitle displays directly below the County name. The Table of Contents on the left hand side will allow you to easily navigate the document by clicking on a specific portion of the report. In this case to the Map Unit Legend.

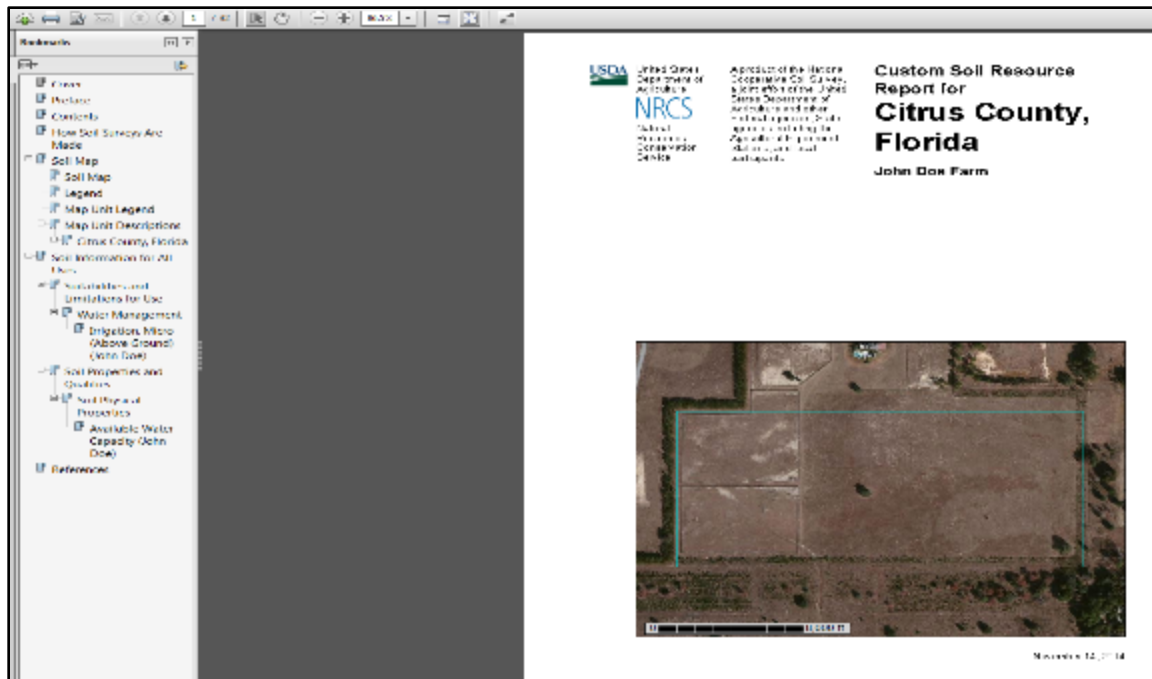

The Table of Contents on the left hand side will allow you to easily navigate the document by clicking on a specific portion of the report. In this case to the Map Unit Legend.

THIS PAGE INTENTIONALLY LEFT BLANK

Appendix C - Evaluation Spreadsheets

THIS PAGE INTENTIONALLY LEFT BLANK

Table D.1 – List of Irrigation Evaluation Spreadsheets

<u>Spreadsheet</u>	<u>Version</u>
Farm Irrigation Rating Index	1.0
Irrigation Scheduling Guide	1.4
Microirrigation Evaluation	1.1
Solid Set Sprinkler Evaluation	1.1
FL-ENG-442F	1.0
FL-ENG-449A	1/2015
FL-ENG-449B	1/2015

THIS PAGE INTENTIONALLY LEFT BLANK

Appendix D - Glossary, Conversion Tables and References

THIS PAGE INTENTIONALLY LEFT BLANK

Glossary

Allowable depletion – That part of soil moisture stored in the plant root zone managed for use by plants, usually expressed as equivalent depth of water in acre inches per acre, or inches.

Application efficiency (Ea) – The ratio of the average depth of irrigation water infiltrated and stored in the root zone to the average depth of irrigation water applied, expressed as a percentage. Also referred to as AE.

Application efficiency low quarter (Eq) – The ratio of the average of the lowest $\frac{1}{4}$ of measurements of irrigation water infiltrated to the average depth of irrigation water applied, expressed as a percentage. Also called AELQ. Used as an indication for uniformity of application.

Application rate – Usually expressed in inches per hour.

Application rate, sprinkler – The rate at which water is applied to a given area by a sprinkler system.

Application time, set time – The amount of time that water is applied to an irrigation set.

Available soil water – The difference between actual water content of a soil and the water held by that soil at the permanent wilting point.

Available water capacity (AWC) – The portion of water in a soil that can be readily absorbed by plant roots of most crops, expressed in inches per inch, inches per foot, or total inches for a specific soil depth. It is the amount of water stored in the soil between field capacity (FC) and permanent wilting point (WP). It is typically adjusted for salinity (electrical conductivity) and rock fragment content. Also called available water holding capacity (AWHC).

Average daily peak use rate – Calculated or measured water used by plants in 1 day through evapotranspiration, expressed as inches per day (in/day).

Backflow prevention device – Safety device that prevents the flow of water from the water distribution system back to the water source.

Bubbler irrigation – Micro irrigation application of water to flood the soil surface using a small stream or fountain. The discharge rates for point-source bubbler emitters are greater than for drip or subsurface emitters, but generally less than 1 gallon per minute (225 L/h). A small basin is usually required to contain or control the water.

Chemigation – Application of chemicals to crops through an irrigation system by mixing them with irrigation water.

Christiansen's uniformity coefficient (CU) – A measure of the uniformity of irrigation water application. The average depth of irrigation water infiltrated minus the average absolute deviation from this depth, all divided by the average depth infiltrated. Also called coefficient of uniformity. Typically used with sprinkle irrigation systems.

Compensating emitter – Microirrigation system emitters designed to discharge water at a near constant rate over a wide range of lateral line pressures.

Consumptive use – See Evapotranspiration and Crop evapotranspiration.

Continuous flushing emitter – Microirrigation system emitters designed to continuously permit passage of large solid particles while operating at a trickle or drip flow, thus reducing filtration requirements.

Crop evapotranspiration (ET_c) – The amount of water used by the crop in transpiration and building of plant tissue, and that evaporated from adjacent soil or intercepted by plant foliage. It is expressed as depth in inches or as volume in acre inches per acre. It can be daily, peak, design, monthly, or seasonal. Sometimes referred to as consumptive use.

Crop growth stages Periods of like plant function during the growing season. Usually four or more periods are identified:

Initial – Between planting or when growth begins and approximately 10 percent ground cover.

Crop development – Between about 10 percent ground cover and 70 or 80 percent ground cover.

Mid-season – From 70 or 80 percent ground cover to beginning of maturity.

Late – From beginning of maturity to harvest.

Crop rooting depth – Crop rooting depth is typically taken as the soil depth containing 80 percent of plant roots, measured in feet or inches.

Crop water use – Calculated or measured water used by plants, expressed in inches per day. Same as ET_c except it is expressed as daily use only.

Depth of irrigation – (1) Depth of water applied, measured in acre inches per acre. (2) Depth of soil affected by an irrigation event.

Distribution uniformity (DU) – The measure of the uniformity of irrigation water distribution over a field. NRCS typically uses DU of low ¼. DU of low ¼ is the ratio of the average of the lowest one-fourth of measurements of irrigation water infiltrated to the average depth of irrigation water infiltrated, expressed as a decimal. Each value measured represents an equal area.

Distribution system – A network of open canals or pipelines to distribute irrigation water at a specific design rate to multiple outlets on a farm or in a community.

Drip irrigation – A micro irrigation application system wherein water is applied to the soil surface as drops or small streams through emitters. Discharge rates are generally less than 2 gallons per hour (8 L/h) for single outlet emitters and 3 gallons per hour (12 L/h) per meter for line source emitters.

Effective precipitation (Pe) – The portion of precipitation that is available to meet crop evapotranspiration. It does not include precipitation that is lost to runoff, deep percolation, or evaporation before the crop can use it.

Effective rooting depth – The depth from which roots extract water. The effective rooting depth is generally the depth from which the crop is currently capable of extracting soil water. However, it may also be expressed as the depth from which the crop can extract water when mature or the depth from which a future crop can extract soil water. Maximum effective root depth depends on the rooting capability of the plant, soil profile characteristics, and moisture levels in the soil profile.

Emitter – A small micro irrigation dispensing device designed to dissipate pressure and discharge a small uniform flow or trickle of water at a constant discharge. Also called a dripper or trickler.

Compensating emitter – Designed to discharge water at a constant rate over a wide range of lateral line pressures.

Continuous flushing emitter – Designed to continuously permit passage of small solid particles while operating at a trickle or drip flow, thus reducing filter fineness requirements.

Flushing emitter – Designed to have a flushing flow of water to clear the discharge opening every time the system is turned on.

Line-source emitter – Water is discharged from closely spaced perforations, emitters, or a porous wall along the tubing.

Long-path emitter – Employs a long capillary sized tube or channel to dissipate pressure.

Multi-outlet emitter – Supplies water to two or more points through small diameter auxiliary tubing.

Orifice emitter – Employs a series of orifices to dissipate pressure.

Vortex emitter – Employs a vortex effect to dissipate pressure.

Evapotranspiration (ET) – The combination of water transpired from vegetation and evaporated from soil and plant surfaces. Sometimes called consumptive use.

Feel and appearance method – A method to estimate soil moisture by observing and feeling a soil sample with the hand and fingers. With experience, this method can be accurate.

Field capacity – The amount of water retained by a soil after it has been saturated and has drained freely by gravity. Can be expressed as inches, inches per inch, bars suction, or percent of total available water.

Float valve – A valve, actuated by a float, that automatically controls the flow of water.

Flood irrigation, wild flooding – A surface irrigation system where water is applied to the soil surface without flow controls, such as furrows, borders (including dikes), or corrugations.

Flushing emitter – A micro irrigation application device designed to have a flushing flow of water to clear the discharge opening each time the system is turned on.

Follow-up evaluation – A low pressure system to low pressure system or standard system to standard system evaluation once the irrigator has adhered to MIL system recommendations on the current systems operation and maintenance and refer back to the initial evaluation.

Foot valve – (1) A check valve used on the bottom of the suction pipe to retain the water in the pump when it is not in operation. (2) A valve used to prevent backflow.

Frost protection – Applying irrigation water to affect air temperature, humidity, and dew point to protect plant tissue from freezing. The primary source of heat (called heat of fusion) occurs when water turns to ice, thus protecting sensitive plant tissue. Wind machines and heating devices are also used.

Full irrigation – Management of water applications to fully replace water used by plants over an entire field.

Fungicide – Chemical pesticide that kills fungi or prevents them from causing diseases on plants.

Furrow – (1) A trench or channel in the soil made by a tillage tool. (2) Small channel for conveying irrigation water downslope across the field. Sometimes referred to as a rill or corrugation.

Furrow irrigation – A surface irrigation system where water is supplied to small channels or furrows to guide water downslope and prevent cross flow. Called rill or corrugation irrigation in some areas.

Furrow stream – The streamflow in a furrow, corrugation, or rill.

Gate, slide gate – A device used to control the flow of water to, from, or in a pipeline or open channel. It may be opened and closed by screw or slide action either manually or by electric, hydraulic, or pneumatic actuators. In open channels, gates slide on rails and are used to control drainage or irrigation water.

Gated pipe – Portable pipe that has small gates installed at regular intervals along one side for distributing irrigation water to corrugations, furrows, or borders.

Ground water – Water occurring in the zone of saturation in an aquifer or soil.

Growing season – The period, often the frost-free period, during which the climate is such that crops can be produced.

Hydrant – An outlet, usually portable, used for connecting surface irrigation pipe to an alfalfa valve outlet.

Infiltration, infiltration rate – The downward flow of water into the soil at the air-soil interface. Water enters the soil through pores, cracks, wormholes, decayed-root holes, and cavities introduced by tillage. The rate at which water enters soil is called intake rate or infiltration rate.

Initial evaluation – The first evaluation performed on an irrigation system.

Irrigable area – Area capable of being irrigated, principally based on availability of water, suitable soils, and topography of land.

Irrigation – Applying water to the land for growing crops, reclaiming soils, temperature modification, improving crop quality, or other such uses.

Irrigation frequency, interval – The time, generally in days, between irrigation events. Usually considered the maximum allowable time between irrigation's during the peak ET period.

Irrigation method – One of four irrigation methods used to apply irrigation water: surface, sprinkle, micro, and subirrigation. One or more irrigation systems can be used to apply water by each irrigation method.

Irrigation scheduling – Determining when to irrigate and how much water to apply, based upon measurements or estimates of soil moisture or crop water used by the plant.

Irrigation set – The area irrigated at one time within a field.

Irrigation set time, irrigation period – The amount of time required to apply a specific amount of water during one irrigation to a given area, typically refilling the plant root zone to field capacity minus expected rainfall.

Irrigation system – Physical components (pumps, pipelines, valves, nozzles, ditches, gates, siphon tubes, turnout structures) and management used to apply irrigation water by an irrigation method. All properly designed and managed irrigation systems have the potential to uniformly apply water across a field.

Irrigation water management – Managing water resources (precipitation, applied irrigation water, (IWM) humidity) to optimize water use by the plant. Soil and plant resources must also be considered.

Irrigation water requirement – The calculated amount of water required to replace soil water used by the crop (soil water deficit), for leaching undesirable elements through and below the plant root zone, plus other needs; after considerations are made for effective precipitation.

Leaching fraction – The ratio of the depth of subsurface drainage water (deep percolation) to the depth of infiltrated irrigation water. (See Leaching requirement.)

Leaching requirement – (1) The amount of irrigation water required to pass through the plant root zone to reduce the salt concentration in the soil for reclamation purposes. (2) The fraction of

water from irrigation or rainfall required to pass through the soil to prevent salt accumulation in the plant root zone and sustain production. (See Leaching fraction.)

Leaching – Removal of soluble material from soil or other permeable material by the passage of water through it.

Length of run – The distance down the furrow, corrugation, or border to the planned end of irrigation, typically the edge of the field.

Line-source emitter – Water is discharged from closely spaced perforations, emitters, or a porous wall along a micro irrigation lateral.

Long-path emitter – Employs a long capillary sized tube or channel to dissipate pressure and discharge water in discrete droplets or seeps.

Low energy precision application (LEPA) – A water, soil, and plant management regime where precision down-in-crop applications of water are made on the soil surface at the point of use. Application devices are located in the crop canopy on drop tubes mounted on low pressure center pivot and linear move sprinkler irrigation systems. Generally limited to circular plantings on less than 1 percent slopes and no translocation of applied water. Furrow dikes, good soil condition, and crop residue are usually required to control water translocation.

Low pressure in canopy (LPIC) – A low pressure in-canopy system that may or may not include a complete water, soil, and plant management regime as required in LEPA. Application devices are located in the crop canopy with drop tubes mounted on low pressure center pivot and linear move sprinkler irrigation systems. Limited water translocation within the field and some minor non uniformity of water application usually exists.

Management allowed depletion (MAD) – The planned soil moisture deficit at the time of irrigation. It can be expressed as the percentage of available soil water capacity or as the depth of water that has been depleted from the root zone. Sometimes called allowable soil depletion.

Maximum application rate – The maximum discharge, in inches per hour, at which sprinklers can apply water without causing significant translocation.

Microirrigation – The frequent application of small quantities of water as drops, tiny streams, or miniature spray through emitters or applicators placed along a water delivery line. The microirrigation method encompasses a number of systems or concepts, such as bubbler, drip, trickle, line source, mist, or spray.

Multi-outlet emitter – Supplies water to two or more points through small diameter auxiliary tubing.

Net irrigation – The actual amount of applied irrigation water stored in the soil for plant use or moved through the soil for leaching salts. Also includes water applied for crop quality and temperature modification; i.e., frost control, cooling plant foliage and fruit. Application losses, such as evaporation, runoff, and deep percolation, are not included. Generally measured in inches of water depth applied.

Net irrigation water requirement – The depth of water, exclusive of effective precipitation, stored soil moisture, or ground water, that is required for meeting crop evapotranspiration for crop production and other related uses. Such uses may include water required for leaching, frost protection, cooling, and chemigation.

Orifice emitter – A microirrigation system application device employing a series of orifices to dissipate pressure.

Orifice An opening with a closed perimeter through which water flows. Certain shapes of orifices are calibrated for use in measuring flow rates.

Overhead irrigation – See Sprinkler irrigation.

Peak use rate – The maximum rate at which a crop uses water, measured in inches (acre inches per acre) per unit time; i.e., inches per month, inches per week, inches per day.

Percolation – Movement of the water through the soil profile. The percolation rate is governed by the permeability or hydraulic conductivity of the soil. Both terms are used to describe the ease with which soil transmits water.

Permeability – (1) Qualitatively, the ease with which gases, liquids, or plant roots penetrate or pass through a layer of soil (2) Quantitatively, the specific soil property designating the rate at which gases and liquids can flow through the soil or porous media.

Potential Water Savings (PWS) (ac-ft) – The total amount of water that can be saved annually by following the recommendations derived from an irrigation evaluation.

PWS Due to Irrigation System Efficiency Improvements (ac-ft) – The amount of irrigation water that can be saved annually by improving the DU or EU of the irrigation system, which should lead to a reduction in hours of irrigation required.

PWS Due to Irrigation System Scheduling (ac-ft) – The amount of irrigation water that can be saved annually if schedule changes (run time and frequency) alone are implemented.

PWS Due to the Repair of Leaks and/or any Applicable Irrigation System Components (ac-ft) – the amount of irrigation water that can be saved annually by repairing irrigation system leaks or components, or replacing faulty irrigation system components.

Rainfall management – Managing soil, water, and plant resources to optimize use of rainfall.

Replacement – To replace or convert the entire irrigation system to a more efficient irrigation system. For example, converting overhead sprinkler irrigation system to an irrigation system that is more efficient such as a microirrigation system or from a high pressure center pivot to a low pressure center pivot system. Any evaluation performed on a replacement will refer back to the last evaluation performed that is on file.

Retrofit – To change the irrigation nozzles on the existing irrigation system and replace them with new and more efficient irrigation nozzles. If low pressure nozzles are replaced with new low pressure nozzles, this will be considered a retrofit.

Return-flow facilities, reuse facilities – A system of ditches, pipelines, pump(s), and reservoirs to collect and convey surface or subsurface runoff from an irrigated field for reuse. Sometimes called tailwater reuse facilities or pump-back systems.

Root zone – Depth of soil that plant roots readily penetrate and in which the predominant root activity occurs. Preferred term is plant root zone.

Saturation – To fill all (100%) voids between soil particles with water.

Soil crusting – Compaction of the soil surface by droplet impact from sprinkle irrigation and precipitation. Well graded, medium textured, low organic matter soils tend to crust more readily than other soils.

Soil compaction – Consolidation, increase in bulk density, reduction in porosity, and collapse of the soil structure when subjected to surface loads or the downward and shearing action of tillage implement surfaces.

Soil horizon – A layer of soil differing from adjacent genetically related layers in physical, chemical, and biological properties or characteristics.

Soil profile – Vertical section of the soil from the surface through all its horizons.

Spray irrigation – The application of water by a small spray or mist to the soil surface where travel through the air becomes instrumental in the distribution of water. Used with sprinkler and microirrigation methods.

Sprinkler distribution pattern – Water depth-distance relationship measured from a single sprinkler head.

Sprinkler head – A nozzle or device, which may or may not rotate, for distributing water under pressure through the air. Water is delivered to sprinkler heads by a system of pressurized pipelines.

Sprinkle irrigation – Method of irrigation in which water is sprayed or sprinkled through the air to plant or ground surface. See Sprinkler irrigation system.

Sprinkler irrigation system – Facility used to distribute water by the sprinkle irrigation method. Sprinkler systems are defined in the following general categories:

Periodic-move system – A system of laterals, sprinkler heads (gun types), or booms that are moved between irrigation settings. They remain stationary while applying water.

Fixed/solid-set system – A system of portable surface or permanently buried laterals totally covering the irrigated area or field. Typically several adjacent laterals or heads are operated at one time. Portable laterals are typically removed from the field at end of germination, plant establishment, or the irrigation season and are replaced the next irrigation season.

Continuous/self-move system – A lateral, sprinkler (traveler), or boom that is continuous or self moving while water is being applied. Power for moving the facility is typically provided

by electric or hydraulic (water) motors or small diesel engines. Specific types of sprinkler systems under each general category include:

Boom – An elevated, cantilevered boom with sprinklers mounted on a central stand. The sprinkler-nozzle trajectory back pressure rotates the boom about a central pivot, which is towed across the field by a cable attached to a winch or tractor. Can be either periodic move or continuous move type system.

Center pivot – An automated irrigation system consisting of a sprinkler lateral rotating about a pivot point and supported by a number of self propelled towers. Water is supplied at the pivot point and flows outward through the pipeline supplying the individual sprinklers or spray heads. A continuous/self-move type system.

Corner pivot - An additional span or other equipment attached to the end of a center pivot irrigation system that allows the overall radius to increase or decrease in relation to field boundaries.

Gun type – A single sprinkler head with large diameter nozzles, supported on skids or wheels. Periodically moved by hand or mechanically with a tractor, cable, or water supply hose. When the travel lane (or path) has been irrigated, the sprinkler head is relocated at the far end of the next travel lane and irrigation continues.

Lateral move, linear move – An automated irrigation machine consisting of a sprinkler line supported by a number of self-propelled towers. The entire unit moves in a generally straight path perpendicular to the lateral and irrigates a basically rectangular area. A continuous/self move type system.

Linear move – See Lateral move.

Portable hand-move – Sprinkler system moved to the next irrigation set by uncoupling and picking up the pipes manually, requiring no special tools. A periodic move type system.

Side-move sprinkler – A sprinkler system with the supply pipe supported on carriages and towing small diameter trailing pipelines each fitted with several sprinkler heads. A periodic move type system.

Side-roll (wheel line) sprinkler – The supply pipe is usually mounted on wheels with the pipe as the axle and where the system is moved across the field by rotating the pipeline by engine power. A periodic move type system.

Solid-set, fixed-set – System that covers the complete field with pipes and sprinklers in such a manner that all of the field can be irrigated without moving any of the system. Laterals may be permanently buried or portable.

Towed sprinkler – System where lateral lines are mounted on wheels, sleds, or skids and are pulled or towed in a direction approximately parallel to the lateral. Rollers or wheels are secured in the ground near the main water supply line to force an offset in the tow path equal to half the distance the lateral would have been moved by hand. A periodic move type system.

Traveler – A single large, gun type sprinkler head with a large diameter nozzle mounted on a unit that is continuously moved across the field by supply hose or cable. The hose reel may be mounted with the sprinkler head on a trailer or on a separate trailer secured at the water supply main line, which is typically located at or near the center of the field. Sometimes

called traveling gun or hose pull.

Subirrigation – Applying irrigation water below the ground surface either by raising the water table or by using a buried perforated or porous pipe system that discharges water directly into the plant root zone. Primary source of water for plant growth is provided by capillary rise of soil water above the water table (up flux) or capillary water movement away from the line source.

Surface irrigation – Broad class of irrigation systems in which water is distributed over the soil surface by gravity flow (preferred term is surface irrigation method).

Tailwater runoff – Surface irrigation system water leaving a field or farm from the downstream end of a graded furrow, corrugation, border. Best surface irrigation distribution uniformity across the field is obtained with 30 to 50 percent tailwater runoff, unless tailwater reuse facilities are used.

Tensiometer – Instrument, consisting of a porous cup filled with water and connected to a manometer or vacuum gauge, used for measuring the soil-water matric potential.

Total dissolved solids (TDS) – The total dissolved mineral constituents of water.

Translocation – Movement of water to other area(s) than where it was applied.

Transpiration – The process of plant water uptake and use, beginning with absorption through the roots and ending with transpiration at the leaf surfaces. See Evapotranspiration.

Trickle irrigation – A micro irrigation system (low pressure and low volume) wherein water is applied to the soil surface as drops or small streams through emitters. Preferred term is Drip irrigation.

Unavailable soil water – That portion of water in a soil held so tightly by adhesion and other soil forces that it cannot be absorbed by plants rapidly enough to sustain growth without permanent damage. The soil water remaining at the permanent wilting point of plants.

Valve – A device to control flow that includes:

Pressurized system:

Air relief valve – Device that releases air from a pipeline automatically without permitting loss of water.

Air vacuum, air relief valve – Device that releases air from a pipeline automatically without permitting loss of water or admits air automatically if the internal pressure becomes less than atmospheric.

Backflow prevention valve – A check valve that allows flow in one direction. When closed, air is admitted to the low pressure (supply) side to prevent siphoning or backflow of water and chemicals to a water source.

Ball valve – A valve in a pipeline used to start or stop flow by rotating a sealed ball with a transverse hole approximately equal to the diameter of the pipeline. Ball rotation is typically 90 degrees for single-port control. With hole modifications, several outlets may be controlled. In this case, only partial rotation of the handle may be used. Ball valves should be opened and closed slowly to avoid high surge pressures. Head loss through a ball valve is very low.

Butterfly valve – A valve in a pipeline to start or stop flow by rotating a disk 90 degrees. The disk is about the same diameter as the pipeline. Butterfly valves should be opened and closed slowly to avoid high surge pressures (water hammer). Head loss through a butterfly valve is low.

Check valve – Valve used in a pipeline to allow flow in only one direction.

Drain valve – (a) Automatic has spring-loaded valve that automatically opens and drains the line when the pressure drops to near zero. (b) Flushing type has a valve on the end of a line to flush out dirt and debris. This may be incorporated into an end plug or end cap.

Float valve – A valve, actuated by a float, that automatically controls the flow of water.

Gate valve – A valve in a pipeline used to start or stop water flow. It may be operated by hand with or without mechanical assistance or by high or low voltage (solenoid) electric controlled mechanical assistance. Gate valves consist of seated slide or gates operating perpendicular to the flow of water. Head loss through a gate valve is typically less than a globe valve, but more than a ball or butterfly valve.

Globe valve – A valve in a pipeline used to start or stop water flow. Globe valves stop flow by positioning a disk and gasket over a machined seat about the same diameter as the pipe. Globe valves are limited to smaller sizes because of the high velocities and very high head loss through the valve.

Pressure relief valve – A spring loaded valve set to open at a pressure slightly above the operating pressure, used to relieve excessive pressure and surges.

Solenoid valve – A misused term meaning a low voltage electrically controlled, mechanically actuated valve; typically a gate valve. Often a spring is used to hold the valve in a closed (or open) position when water pressure is low or electric energy is discontinued. (When ignition electric energy for an internal combustion engine or electric energy to a motor is discontinued, a spring closes the valve.)

Vacuum relief valve – Valve used to prevent a vacuum in pipelines and avoid collapsing of thin-wall pipe.

Non-pressure or very low pressure system:

Alfalfa valve – An outlet valve attached to the top of a short vertical pipe (riser) with an opening equal in diameter to the inside diameter of the riser pipe and an adjustable lid or cover to control water flow. A ring around the outside of the valve frame provides a seat and seal for a portable hydrant. Typically used in border or basin irrigation.

Orchard valve – An outlet valve installed inside a short vertical pipe (riser) with an adjustable cover or lid for flow control. Similar to an alfalfa valve, but with lower flow capacity. Typically used in basin irrigation.

Surge valve – A device in a pipe T fitting to provide flow in alternate directions at timed intervals. Used in surge irrigation.

Vortex emitter – A microirrigation water application device that employs a vortex effect to dissipate pressure.

Water amendment – (1) Fertilizer, herbicide, insecticide, or other material added to water for the enhancement of crop production. (2) A chemical water treatment to reduce drip irrigation system emitter clogging.

Water holding capacity – Total amount of water held in the soil per increment of depth. It is the amount of water held between field capacity (FC) and oven dry moisture level, expressed in inch per inch, inch per foot, or total inches for a specific soil depth. Soils that are not freely drained because they have impermeable layers can have temporary saturated conditions just above the impermeable layers. This can temporarily increase water holding capacity. Sometimes called total water holding capacity. See Available water capacity.

Water table – The upper surface of a saturated zone below the soil surface where the water is at atmospheric pressure.

Conversion Tables

Irrigation related units conversion factors

<u>Volume</u>	
1 gallon (gal)	= 231 cubic inches (in ³) = 0.1337 cubic feet (ft ³) = 3.785 liters (l)
1 million gallons (mg)	= 3.0689 acre-feet (ac-ft) = 133,681 cubic feet (ft ³)
1 cubic foot water (ft ³)	= 1728 cubic inches (in ³) = 7.4805 gallons = 28.316 liters
1 acre-inch (ac-in)	= 27,152.4 gallons
1 acre-foot (ac-ft)	= amount of water to cover 1 acre 1 foot deep = 43,560 cubic foot (ft ³) = 325,828.8 gallons = 12 acre-inches (ac-in)
1 cubic inch/in (in ³ /in)	= 16.387 milliliter/inch (ml/in)
1 cubic meter (m ³)	= 264.2 gallons (gal)
1 liter (l)	= 0.2642 gallons (gal) = 1000 milliliters (ml)
<u>Length</u>	
1 millimeter (mm)	= 0.03937 inch (in)
1 centimeter (cm)	= 0.3937 inch (in)
1 meter (m)	= 39.37 inches (in) = 3.2808 feet (ft)
1 kilometer (km)	= 3,280.8 feet (ft)
1 mile (mi)	= 5,280 feet (ft) = 1.60934 kilometers (km)

Irrigation related units conversion factors - Continued

Rate of Flow

1 acre-inch per day (ac-in/day)	= 18.9 gallons per minute (gpm)
1 acre-inch per hr. (ac-in/hr.)	= 452.57 gallons per minute (gpm)
1 million gallons per day(mgd)	= 1.547 cubic feet per second (ft ³ /s) = 695 gallon per minute (gpm)
1 cubic foot per second	= 448.83 (typically rounded to 450) gallons per minute (gpm) = 7.48 gallons per second = 0.646 million gallons per day (mgd) = 0.992 (typically rounded to 1) acre-inch per hour (ac-in/hr.) = 1.983 (typically rounded to 2) acre-feet per day (ac-ft/d) = 40 miners inches (11.25 gpm) - AZ, CA, MT, NV, OR = 50 miners inches (9 gpm) – ID, KA, NE, NM, ND, UT = 38.4 miners inches – CO
1 gallon per minute (gpm)	= 1440 gallons per day (gpd) = 0.0023 cubic feet per second (cfs)
1 gallon per hour	= 0.951 milliliter per second (ml/sec)
1 cubic foot per minute (cfm)	= 7.48 gallons per minute (gpm)

Weight

1 gallon of water weighs	= 8.326 pounds (lb)
1 cubic foot of water weighs	= 62.428 pounds (lb)

Area

1 acre (ac)	= 43,560 square feet (ft ²)
1 hectare (ha)	= 2.471 acres

Pressure units

1 atmosphere	= 14.696 pounds per square inch (lb/in ²) = 2116.2 pounds per square foot (lb/ft ²) = 33.899 feet of water = 29.92 inches of mercury
1 pound per square inch	= 144 pounds per square foot = 2.31 feet of head of water
1 pound per square foot	= 48 Pa = 0.048 kPa
1 foot head of water (ft)	= 0.433 pounds per square inch = 0.0295 atmospheres (bars) = 0.883 inches of Mercury (Hg)
1 inch of mercury (Hg)	= 1.133 feet of water

Irrigation related units conversion factors - Continued

Temperature

Degrees C = $(5/9)(F-32^{\circ})$

Degrees F = $(9/5) C+32^{\circ}$

Energy Units

1 hp = 0.746 kw

1 kw = 1.3405 hp

Soil and Water Chemistry Units

1 meq/liter = 1 mg/liter/equivalent weight

1 mg/L = 1 ppm = 0.227 lbs/ac-in = 8.35×10^6 lbs/gal

1 ml of water = 1 cc water

1 ml water = 1 gram

Element	Equivalent Weight	Element	Equivalent Weight
Ca	2.0	CO ₃	30
Mg	12.2	HCO ₃	61
Na	23	SO ₄	48
Cl	35.4	NO ₃ -N	14

Common conversion units pertaining to water quality

10 ppm Nitrate – Nitrogen = 27 lb/ac-ft of water

= 2.25 lb/ac-in of water

REFERENCES

Florida NRCS Conservation Practice Standards

Irrigation Pipeline, Code 430

Irrigation Reservoir, Code 436

Irrigation System, Microirrigation, Code 441

Irrigation System, Surface and Subsurface, Code 443

Irrigation System, Tailwater Recovery, Code 447

Irrigation Water Management, Code 449

Sprinkler System, Code 442

NRCS National Engineering Handbook (NEH), Part 623, Irrigation

<http://directives.sc.e.gov.usda.gov/viewerFS.aspx?hid=21440>

NRCS NEH, Part 650, Florida Supplement, Chapter 1, Section A, Procedure for Documenting Planning, Design, Construction, and Checkout of Engineering Conservation Practices

NRCS NEH, Part 652, Irrigation Guide, Florida Supplement,

<http://www.fl.nrcs.usda.gov/technical/irrigation.html>

NRCS Web Soil Survey,

<http://websoilsurvey.nrcs.usda.gov/app/HomePage.htm>

Mickler, Jon, (January 1996) Mobile Irrigation Laboratory Urban Irrigation Evaluation Training Manual, USDA, Natural Resources Conservation Service, Gainesville, Florida.

University of Florida, Institute of Food and Agricultural Sciences, Florida Automated Weather Network (FAWN)

<http://fawn.ifas.ufl.edu/>

University of Florida, Institute of Food and Agricultural Sciences

<http://solutionsforyourlife.ufl.edu/>

THIS PAGE INTENTIONALLY LEFT BLANK